

MHI
Copy 3

FRANKLIN & MARSHALL
COLLEGE LIBRARY FM 4-112

WAR DEPARTMENT

**COAST ARTILLERY
FIELD MANUAL**



**ANTIAIRCRAFT ARTILLERY
GUNNERY, FIRE CONTROL,
POSITION FINDING,
AND HORIZONTAL FIRE,
ANTIAIRCRAFT AUTOMATIC
WEAPONS
(CASE I FIRING)**

August 22, 1942

BASIC FIELD MANUAL

OPERATIONS IN SNOW AND EXTREME COLD

CHANGE }
No. 2 }WAR DEPARTMENT,
WASHINGTON, September 29, 1942.

FM 31-15, September 18, 1941, is changed as follows:

■ 60. Because carbon dioxide is exhaled from the lungs, it is not advisable to sleep with the head completely covered. Even in the severest cold the nose and mouth should be uncovered.

[A. G. 062.11 (9-22-42).] (C 2, Sept. 29, 1942.)

BY ORDER OF THE SECRETARY OF WAR:

G. C. MARSHALL,
Chief of Staff.

OFFICIAL:

J. A. ULIO,
Major General,
The Adjutant General.

FM 4-112

**COAST ARTILLERY
FIELD MANUAL**



ANTIAIRCRAFT ARTILLERY

**GUNNERY, FIRE CONTROL, POSITION
FINDING, AND HORIZONTAL FIRE,
ANTIAIRCRAFT AUTOMATIC WEAPONS
(CASE I FIRING)**



**UNITED STATES
GOVERNMENT PRINTING OFFICE
WASHINGTON : 1942**

WAR DEPARTMENT,
WASHINGTON, August 22, 1942.

FM4-112, Coast Artillery Field Manual, Antiaircraft Artillery—Gunnery, Fire Control, Position Finding, and Horizontal Fire, Antiaircraft Automatic Weapons (Case I Firing), is published for the information and guidance of all concerned.

[A. G. 062.11 (6-5-42).]

BY ORDER OF THE SECRETARY OF WAR:

G. C. MARSHALL,
Chief of Staff.

OFFICIAL:

J. A. ULIO,
Major General,
The Adjutant General.

DISTRIBUTION:

R and H 1 (2); Bn and H 4 (3); IBn and H 4 (10);
IC 4 (25).

(For explanation of symbols see FM 21-6.)

TABLE OF CONTENTS

	Paragraphs	Page
CHAPTER 1. General.		
SECTION I. General	1-5	1
II. Antiaircraft automatic weapons problem	6-11	3
III. Gun pointer control	12-17	6
IV. On carriage sight control	18-24	9
V. Off carriage sight control	25-32	11
VI. Director control	33-38	13
CHAPTER 2. Dispersion and hit expectancy.		
SECTION I. Dispersion	39-44	16
II. Hit expectancy	45-47	25
CHAPTER 3. Calculation of leads.		
SECTION I. Elements of data	48-53	28
II. Firing tables	54-57	35
III. Methods of lead calculation	58-64	41
CHAPTER 4. Lead curves and charts.		
SECTION I. Lead curves and lead charts for constant altitude courses	65-67	76
II. Lead charts for dive targets	68-72	83
CHAPTER 5. Lead characteristics	73-80	102
CHAPTER 6. Horizontal fire.		
SECTION I. General	81-82	130
II. Antimechanized defense	83-86	130
III. Assault of fortifications	87-88	138
IV. Engagement of water-borne tar- gets	89-91	139
V. Lateral leads and lead charts	92-95	141
CHAPTER 7. Observation and adjustment of fire.		
SECTION I. Methods of observation	96-99	151
II. Individual tracer control	100-101	157
III. Central tracer control	102-106	159
IV. Fire adjustment	107-109	161
V. Data transmission	110-113	165
CHAPTER 8. Range section	114-116	168
CHAPTER 9. Training.		
SECTION I. General	117-120	173
II. Training of gunners and gun pointers	121-123	174
III. Training of adjusters and spotters	124-127	176
IV. Tracer control trainer	128-133	180
V. Subcaliber firing	134	196
APPENDIX		
I. Glossary of symbols, automatic weapons		197
II. Lead charts		199
III. Use of M1 (Crichlow) slide rule		206
IV. Drill table for control equipment set M1		211
INDEX		217

COAST ARTILLERY FIELD MANUAL

ANTIAIRCRAFT ARTILLERY

GUNNERY, FIRE CONTROL, POSITION FINDING, AND
HORIZONTAL FIRE ANTIAIRCRAFT AUTOMATIC
WEAPONS (CASE I FIRING)

(This manual supersedes FM 4-112, July 12, 1940.)

CHAPTER 1

GENERAL

	Paragraphs
SECTION I. General.....	1-5
II. Antiaircraft automatic weapons problem.....	6-11
III. Gun pointer control.....	12-17
IV. On carriage sight control.....	18-24
V. Off carriage sight control.....	25-32
VI. Director control.....	33-38

SECTION I

GENERAL

■ 1. SCOPE.—This manual treats of the theory and practice of gunnery and fire control for antiaircraft artillery automatic weapons when firing by gun pointer and central control methods. The fundamentals of exterior ballistics and gunnery as covered in chapters 1 and 2, FM 4-110, should be carefully studied to acquire a thorough understanding of the general antiaircraft problem. Pertinent definitions and symbols which appear in FM 4-155 and appendix I of this manual should also be studied. A clear understanding should be had of the picture in space of the various elements of data. Case III firing (firing by director control) is completely covered in FM 4-113.

■ 2. GENERAL MISSIONS.—a. The primary mission of antiaircraft artillery automatic weapons is to attack all enemy aircraft within range, particularly low-flying airplanes, to destroy them, to cause them to abandon their missions, or to decrease the efficiency of their operations. *These aerial targets, either low-level or diving, are the most dangerous of all aircraft to our*

personnel and matériel. They strike suddenly, swiftly, and with deadly effect if unopposed. It is difficult to obtain warning of their approach as they invariably use some form of cover such as the sun, clouds, trees, or hills in order to get near their objective unseen and unidentified. The only effective defense against such aircraft is to destroy them in such numbers that the objective to be gained by their attack is not worth the cost.

b. The contingent mission of antiaircraft artillery automatic weapons is defense against mechanized vehicles, and other ground, water, or air-borne targets, for fire against which the characteristics and fire control methods of anti-aircraft artillery automatic weapons are particularly suitable.

■ 3. TYPES OF WEAPONS.—The weapons designed or adopted for this general mission are—

a. *Small arms.*—These include rifles and automatic rifles which fire solid ball ammunition. Such weapons by themselves cannot be considered adequate for local defense, but should always be used to supplement machine-gun fire.

b. *Machine guns.*—These include caliber .30 and caliber .50 machine guns which fire solid ball and tracer ammunition. Such weapons are suitable for local defense or as training weapons. They may also be used for the defense of very small objectives, but consideration must be given to their limited range and effectiveness.

c. *Automatic cannon.*—These include guns of the 20-mm, 37-mm, and 40-mm type that fire high-explosive projectiles with a tracer element and point-detonating fuze, and armor-piercing shot for use against armored vehicles. Such projectiles are highly destructive to airplanes, but hits must be obtained to accomplish the mission as detonation is by contact with the target. To be effective, this type of antiaircraft weapon depends on its ability to open fire quickly, its high rate of fire, and rapid adjustment of fire by observation of tracers.

■ 4. BASIC ASSUMPTIONS.—Effective fire with present antiaircraft automatic weapons equipment is limited by ballistic and gunnery factors to targets within approximately 3 seconds' time of flight of the projectile. The only basic assumption necessary is that the target will fly in a straight line at a

constant speed during this time of flight. The flight of even the latest high-speed aircraft will usually conform to this assumption.

■ 5. IMPORTANCE.—The study of gunnery and fire control for antiaircraft automatic weapons is of special importance for the following reasons:

a. All military units armed with suitable weapons are responsible for their own local antiaircraft defense. They will use all their small arms for this purpose, but machine guns fired by individual tracer control will be their primary defense.

b. The short time available for opening and adjusting fire with these local defense machine guns requires the individual gunners to be expert in target identification, estimation of certain elements of data, and adjustment of fire by observation of the tracer stream.

c. In antiaircraft automatic weapons units, the individual gun is usually the fire unit. This places the responsibility for fire control upon the enlisted men of the section. The training of these enlisted men will be the greatest problem of the antiaircraft automatic weapons commander.

d. Some, if not all, data for the fire control of antiaircraft automatic weapons must be estimated. Rapidity of opening fire and adjustment require that these estimates be almost instinctive. This can be accomplished only by careful study, understanding of the problem, and training.

SECTION II

ANTIAIRCRAFT AUTOMATIC WEAPONS PROBLEM

■ 6. TARGETS.—The primary target for antiaircraft automatic weapons—the low-flying airplane—is the most versatile of all targets. It not only can move in three dimensions at the will of its pilot, but it also can accomplish its mission in a number of ways and in a very brief period of time. If unopposed, the low-flying airplane can accomplish almost any military mission except that of actually occupying territory. Even this can be accomplished by landing of parachute or air-borne troops. The inability of pursuit aviation and antiaircraft

guns of larger caliber to combat successfully the low-flying airplane has been demonstrated many times. The barrage balloon is an excellent defense in special situations, but the antiaircraft automatic weapon still remains the best all-around defense against such targets.

■ 7. ELEMENT OF TIME.—The most important factor in the antiaircraft automatic weapons problem is *time*. The high speed of the target and its ability to use cover for its approach require that it be quickly taken under fire as soon as observed and identified. This is necessary in order to give sufficient firing time to insure hits before the aircraft can complete its mission or get out of range. Also, continuous and rapid changes in time of flight and angular travel cause rapid changes in the basic firing data. If a low-level (crossing-constant altitude) target traveling 300 miles per hour passes 400 yards from a gun at the midpoint of its course, its angular velocity in azimuth 10 seconds before it reaches the midpoint will be 23 mils per second; at the midpoint, this angular velocity will be 365 mils per second. On such a course the leads will change as much as 40 mils per second. The target should be kept under fire at least 10 seconds, and it will normally take an additional 10 seconds to identify the target, obtain firing data, and open fire. In this total time of 20 seconds, assuming a reasonable target speed of 300 miles per hour, the target will have traveled 3,000 yards or nearly 2 miles. If the target is coming directly at the gun, the range will change from 2,000 yards to 500 yards in 10 seconds. In a 70° dive this target will change altitude from 5,000 feet to 900 feet in 10 seconds. All of these rapid changes in basic elements must be considered in selecting any method of fire control. As these rapid changes practically preclude the accurate measurement of all data, at least some of the data must be estimated.

■ 8. BALLISTIC FACTORS.—*a.* Any gun that will meet the required conditions of flexibility and high rate of fire will either be of small caliber or decidedly heavy and complicated. Up to the present time only small caliber guns have met these conditions satisfactorily.

b. Two of the principal ballistic factors acting upon auto-

matic weapons projectiles are the propelling charge and the ballistic coefficient. The area weight relationship is included in the ballistic coefficient.

(1) The procedure of manufacture is not sufficiently precise to load each projectile case with exactly the same amount of propelling charge. Thus, the initial velocities caused by a difference in loading may vary as much as 150 foot-seconds.

(2) The present type of small caliber projectiles has very poor ballistic qualities as compared with larger caliber projectiles. Practical limitations on the accuracy of manufacture cause individual projectiles to have different ballistic coefficients. The rapidity with which a projectile loses initial velocity is partially a function of the relationship between the weight of the shot and its air resistance. An examination of the firing tables will show that small caliber projectiles lose their velocities faster than large caliber projectiles (see fig. 2).

c. The difference in time of flight from round to round at a given range directly affects the accuracy of fire at that range when firing at a high speed target. Therefore, the accuracy required to get a satisfactory percentage of hits cannot be expected except for a small proportion of the ground impact range of an antiaircraft automatic weapon.

■ 9. GUNNERY FACTORS.—The necessity for flexibility and speed requires that observation and adjustment be practically instantaneous. Adjustment of fire, based on observation of tracer ammunition, is the best way to accomplish this. It is a known fact that as the range increases, the difficulty of tracer observation increases. The longer the time of flight, the greater will be the probability of the target changing its course and speed such as to render fire adjustment ineffective. Moreover, the longer the range, the smaller the angular errors that can be absorbed by the size of the target. The objective of gunnery for automatic weapons is to obtain *at least* one hit on each target in the shortest time possible.

■ 10. SUMMARY OF PROBLEM.—The antiaircraft automatic weapons problem may be summarized as follows:

a. The versatility of the target requires an accurate, flexible, and high velocity gun with a high rate of fire.

b. Fire control must be simple, rapid, and accurate.

c. As fire must be destructive, high-explosive projectiles should be used.

d. Effective fire is limited to short ranges by the ballistic limitations of small projectiles and gunnery factors of the problem.

e. Observation and adjustment, to be effective, must be limited to short times of flight.

■ 11. POSSIBLE SOLUTIONS OF PROBLEM.—*a.* Gun pointer control, in which the gun pointer or pointers have entire charge of fire control.

b. On carriage sight control, where the sight or sights on the gun are controlled from a position on the gun carriage.

c. Off carriage sight control, where the sight or sights on the gun are controlled from a position some distance from the gun.

d. Director control, where there are no sights on the gun and the pointing of the gun is controlled remotely from a director.

SECTION III

GUN POINTER CONTROL

■ 12. GENERAL.—The gun pointer or pointers open fire with an estimated lead and control the fire. They can do this by using either forward area sights or individual tracer control. This form of control, especially with machine guns, gives extreme flexibility, as the gun is normally free mounted, and allows each gun to be its own fire unit.

■ 13. FORWARD AREA SIGHTS.—Such a sight usually has the forward element so designed that leads can be obtained by tracking the target off center on this element. Initial leads are obtained by estimation of course and speed of target. Such a sight is essential if tracers are not available and can well be used at all times to obtain initial leads. Adjustment can be carried on by continuous estimations or by tracer control. A gunner who thoroughly understands the leads and

the possibility of such a sight can get good results at the shorter ranges.

■ 14. INDIVIDUAL TRACER CONTROL.—Without the use of sights, the gun pointer opens fire by leading the target the estimated correct number of target lengths, and swinging with it as in wing shooting. He then adjusts his fire by observation of the tracer stream as one would direct a stream of water from a hose. Such a method of fire control is the simplest as well as the quickest to use. All anti-aircraft automatic weapons troops should have some training in the use of individual tracer control regardless of their type of weapon, for often this simple method will be the only one available. With the proper training and high morale of these gun crews, this method will prove effective against airplanes coming directly at them, and on crossing targets at short ranges.

■ 15. ADVANTAGES.—*a.* Gun pointer control is the simplest and most rapid method of fire control. For that reason it must always be considered as an available emergency method. When not on the alert and when the guns must be manned with the fewest possible number of gunners, this method can be exercised quickly and with the fewest men.

b. Forward area sights are essential when tracer ammunition is not available. A gunner who thoroughly understands the leads and the possibility of such a sight can get results.

c. Forward area sights where two gun pointers are required have proved more successful than individual tracer control. With two gun pointers the problem of selecting a point of aim on the forward element of the sight is simplified. The lateral pointer has only to judge the speed and the angle of approach to estimate fairly accurately the lateral lead required. The vertical pointer can with fair accuracy estimate the vertical lead by the range and the clock hour of approach. With a clock face forward element on the sight, this latter estimation is fairly simple.

d. Forward area sights are the most simple forms for anti-mechanized firing. The target is picked up easily and quickly and rarely lost due to the sight. For speed of getting on target the forward area sight is the best type developed to date.

e. Individual tracer control can be very effective at short ranges and for coming targets. It is probably the best type of control for close-in fighting with antiaircraft machine guns. Given ball, armor-piercing, and tracer ammunition that have very nearly the same ballistic qualities, machine gun fire can be very effective against airplanes within 500 yards of the gun (slant range).

f. Individual tracer control is the only method of fire control that can be used at night, unless targets are sufficiently illuminated to use sights. It frequently happens that airplanes can be seen close in at night by their exhaust or due to moonlight, but not sufficiently to use sights. Tracers from other guns passing near the airplane or the airplane's own guns firing will often give sufficient indication of its position to allow effective firing with individual tracer control.

g. The advantage of full automatic fire can be obtained with individual tracer control. The volume of fire thus obtained in some measure makes up for its lack of accuracy. Where firing time is extremely short, such as where a fast airplane sneaks in close before being identified, this quick volume of fire offers the best hope of success.

■ 16. DISADVANTAGE.—*a.* Gun pointer control is the least accurate method of firing. For that reason its use should be considered only as an emergency method for antiaircraft automatic weapons units. For all troops it can be considered the primary method of fire control for purely local defense, that is, for firing on aerial or ground targets coming directly at the unit itself with obvious intent to strafe or bomb the unit.

b. The use of gun pointer control places the whole burden of fire control on the gunner. It must be realized that, in fact, he acts in the capacity of range section and gun section combined. His responsibility includes estimating leads, operating the gun, and controlling the fire. His knowledge must include leads, matériel, ammunition, and observation and adjustment of fire. The selection of soldiers for this position must be made with the greatest care and consideration for their natural ability.

c. When using forward area sights, both leads can seldom be correct at the same instant.

d. When gun pointers also control the fire, it is very difficult for them to track a fast target smoothly. Therefore, the tracer stream is not steady, and observation is very uncertain and difficult.

e. Gun pointers are invariably bothered, both in pointing and in observation, by vibration, smoke, and flash of the firing gun. Frequently they will lose the target and are forced to cease firing to pick it up again. This decreases both the accuracy and the volume of fire.

f. Effective fire cannot be expected beyond 500 yards using gun pointer control. This is mainly due to poor observation, and the size of the target at longer ranges cannot absorb even a small proportion of the errors in pointing.

■ 17. SUMMARY.—Gun pointer control can be considered—

a. The principal method for local defense machine guns.

b. An emergency method of fire control for all anti-aircraft automatic weapons.

c. Effective only within 500 yards.

d. The most flexible and rapid method of control and therefore desirable in close-in defense.

e. Sufficiently effective for antimechanized defense.

SECTION IV

ON CARRIAGE SIGHT CONTROL

■ 18. GENERAL.—This method uses sights on the guns which can be set to the required lateral and vertical leads. The leads are set from a position on the carriage, either by estimation of leads or by means of a simple computer using estimates of various elements of the course and speed of the target. By the latter method either a simple linear speed or angular travel director mounted on the gun carriage can be used for the computation.

■ 19. LEAD CONTROL.—The gun pointers have only to track the target with their sights, and the sights are controlled from a position on the carriage by another man who esti-

mates and sets the leads. Adjustment of fire is continuous by observation of the tracer stream.

■ 20. COURSE AND SPEED LEAD COMPUTER.—A small, simple linear speed lead computer is mounted directly on the carriage. It automatically sets the sights at the proper leads when certain elements of data are set into the computer. These elements include speed of target, range, angle of dive, and direction of flight. This method has been used frequently by European armies. Tests by our service have not been satisfactory, and present policy is to discontinue further experiments.

■ 21. ANGULAR TRAVEL LEAD COMPUTER.—This method employs the angular travel principle of lead computing. Continuous tracking of the target by the gun pointers set horizontal and vertical rates into a simple computer mounted in the gun carriage. The only remaining element needed is time of flight to the future position. This must be estimated and set in the computer by the adjuster, who then adjusts fire by observation of the tracer stream.

■ 22. ADVANTAGES.—*a.* All such methods of fire control are utilized to get on a target and open fire quickly. The guns can go into action quickly from the traveling position, as they should require no bore sighting or orientation.

b. Accuracy is much greater than for gun pointer control. Specialized personnel do the estimating, observation, and adjustment. The improved accuracy tends to make this method effective at longer ranges than is possible with gun pointer control.

c. Each gun can be used as a separate fire unit without increasing the personnel required. More vital points and a larger area can be covered with at least some fire.

d. The method should be satisfactory for antimechanized firing.

■ 23. DISADVANTAGES.—*a.* Such methods of fire control are not practical except for cannon type automatic weapons or multiple mounts. Normally, it requires two gun pointers.

b. Too many estimations are required for lead control, and

the course and speed lead computers; and adjustments must be made in terms of two or more elements of data.

c. Accurate and steady gun pointing is difficult due to vibration of the mount, smoke, and flash of firing.

d. Observation of the tracer stream is difficult from a position on the gun carriage. The adjuster is also bothered by vibration, smoke, and flash of firing.

e. The use of sights limits such a method of fire control to daylight or where targets are illuminated at night.

■ 24. SUMMARY.—*a.* On carriage sight control does not offer the flexibility of gun pointer control but is more accurate.

b. Gun pointers and adjusters on the gun carriage are badly handicapped by vibration, flash, and smoke of a continuously fired automatic gun.

c. The method depends to a great extent on estimations which can seldom be accurate.

d. Reports from the present war indicate that it is not entirely satisfactory.

SECTION V

OFF CARRIAGE SIGHT CONTROL

■ 25. GENERAL.—This method of fire control is similar to on carriage sight control except that the control, either by lead estimations or by lead computer, is located at some distance from the gun. This requires a data transmission system to transmit leads to the sights on the gun.

■ 26. CENTRAL TRACER CONTROL.—The fire control system for a platoon of Browning machine guns, caliber .50, M2, water-cooled, mounted on antiaircraft machine-gun mounts, caliber .50, M2, or a platoon of two 37-mm antiaircraft guns M1A2 on carriages M3 is called the automatic gun, antiaircraft, control equipment set M1, or the central tracer control. It consists of movable sights on the guns that can be set to desired leads. These leads are set on a centrally located control box and are transmitted to the sights mechanically by a system of flexible cables. This cable is a simple and trouble-free method of transmission for distances up to 100 feet. Initial leads are estimated by the adjusters located at the con-

trol box, and adjustment is continuous, based on observation of the tracer stream. Lateral and vertical leads are set independently.

■ 27. REMOTE CONTROL.—Observation of the tracer stream is greatly facilitated, especially at the longer ranges, if the lateral and vertical adjusters are considerably separated and placed in a more suitable position to observe lateral or vertical deviations. To use such a system would require a more flexible transmission system than the present mechanical system. Electrical transmission has been tried with excellent results, but the ballistic and gunnery limitations of anti-aircraft automatic weapons now make it appear that such a method of fire control would not be entirely justified.

■ 28. ORIENTED CHARTS.—A form of lead computer which consists of curves of computed leads has been experimented with in connection with the central tracer control equipment. This is similar to the course and speed lead computer in that all elements of the target's course and speed must be estimated in order to select the proper lead curve to follow. Adjustment must be made by jumping from one curve to another, as deviations of the tracer stream are observed.

■ 29. LEAD COMPUTER.—Lead computers similar to those designed for use on the gun carriage will give more accurate results when taken off the gun and placed nearby. These compute the required leads and transmit them to the gun sights through the control box. The control box of the central tracer control equipment is made to receive such data, combine it with adjustments, and transmit the corrected lead to the gun sights. Such computers have been tried but so far have never given consistent results. Here, as in so many other methods of fire control, there are too many estimations to be made and too many possibilities of errors in transmission and gun pointing to take full advantage of the accuracy of a lead computer.

■ 30. ADVANTAGES.—*a.* The off carriage method of fire control allows the firing of two or more guns together as a fire unit, thereby increasing the volume of fire and improving observation of fire.

b. Such a method gives the best observation of the tracer stream, therefore the best opportunity to adjust fire continuously.

c. Except in distant remote control, the transmission system is simple, trouble-free, and requires no electricity for operation.

d. Accuracy of the fire unit is greatly increased.

■ 31. DISADVANTAGES.—*a.* Such a method of fire control requires additional equipment and personnel.

b. It requires bore sighting and synchronizing to bring all guns of the fire unit to fire together.

c. It does not eliminate the errors of gun pointing.

d. Flexibility of the fire unit is greatly decreased.

e. Consistent hitting on each target has not been obtained, while a high percentage of hits has been obtained on a series of targets.

■ 32. SUMMARY.—*a.* Central tracer control has proved much more effective than either gun pointer control or on carriage sight control.

b. The inherent errors of gun pointing will not allow full advantage to be taken of lead computers or of continuous observation and adjustment.

c. Such a system, while gaining somewhat in accuracy, loses considerable in flexibility. It requires more matériel and personnel as well as more time to set up and go into action.

SECTION VI

DIRECTOR CONTROL

■ 33. GENERAL.—It is an acknowledged fact that a director can track the present position of a target much more accurately than can be done with sights on the gun. To take advantage of this accuracy, the gun must be remotely controlled from the director. The final degree of accuracy of this method of fire control can therefore be separated into the accuracy of the gun and ammunition and the accuracy of the computed leads. The ballistic and gunnery factors of anti-aircraft automatic weapons limit the accuracy of the gun to short ranges. Thus the director, in addition to being rugged,

simple, and rapid of operation, should compute leads to an accuracy within the limitations of accuracy of fire. Within these limitations the director can be of the approximate angular travel type or of an exact angular travel or linear speed type.

■ 34. APPROXIMATE DIRECTOR.—*a.* An approximate director based on the angular travel principle is more feasible than any other type. It requires only the measurement of both horizontal and vertical angular travel and their multiplication by a time of flight to give approximate leads. For short times of flight these leads would be sufficiently accurate. The errors would be absorbed by the size of the target. The principal requirements are smooth rates and accurate tracking.

b. The present standard director is the director M5, which is based on the angular travel principle. This director is used with the 40-mm antiaircraft gun on the carriage M2 and the 37-mm antiaircraft gun on the carriage M3A1. The director tracks the target in present position, computes the leads and superelevation, and transmits future azimuth and future quadrant elevation to the gun. The director M6 is identical with the director M5 except that it is designed to be employed with British equipment. (See FM 4-113.)

■ 35. EXACT DIRECTOR.—The British Vickers and the M4 are such directors. It is possible that this type could be built to compute leads with sufficient rapidity for use with anti-aircraft automatic weapons. However, such a director would not be simple or rugged. It is also doubtful if such a degree of accuracy is required by small caliber guns, due to their inherent ballistic limitations.

■ 36. ADVANTAGES.—*a.* More accurate tracking can be accomplished with a director.

b. More accurate leads can be computed.

c. Control and adjustment of fire can be in terms of one element, either range or time of flight.

d. Such a system will give a better chance of obtaining a hit on each target.

e. Such a system should give better results at longer ranges than any other system.

■ 37. DISADVANTAGES.—*a.* The disadvantages of director control are the loss of time in getting on the target and obtaining smooth rates.

b. Additional equipment and personnel are required, especially electrical equipment with its possible failure under field conditions.

c. Accurate orientation and trial shots are required.

d. Such a method usually cannot make use of the full rate of fire of automatic weapons.

■ 38. SUMMARY.—The many variations in the anti-aircraft automatic weapons problem practically prevent the use of one method of fire control that will give the best results under all conditions. Some form of tracer observation is the only method that will give sufficient speed and continuous adjustment. Individual tracer control must always be considered an available emergency method of fire control, and all fire units must be trained to use it. Regardless of the equipment in use and the method of fire control, a complete knowledge of the fire control problem, leads, their characteristics for type courses, and the variation of the several elements of these courses should be acquired by all anti-aircraft automatic weapons personnel.

CHAPTER 2

DISPERSION AND HIT EXPECTANCY

	Paragraphs
SECTION I. Dispersion.....	39-44
II. Hit expectancy.....	45-47

SECTION I

DISPERSION

■ 39. GENERAL.—*a.* Standard methods of fire control for antiaircraft automatic weapons depend upon the observation of tracer bullets for the adjustment of fire. To assist in observing these tracers, and to insure a reasonable percentage of hits when fire is adjusted, the cone of fire which they form must be as small as possible. This requirement is particularly important at the longer ranges.

b. Spreading of the cone of fire is caused by dispersion. Many factors enter into dispersion. These factors are erratic gun pointing, vibration of the gun and mount, variations in muzzle velocity between shots from the same gun and between guns, and poor bore sighting and synchronization of the fire-control system. Most of these factors can be eliminated or their effect greatly reduced by careful training and proper care and use of equipment.

■ 40. GUN POINTING.—*a.* Gun pointing is the basic factor in the reduction of dispersion when firing using forward area sights or individual tracer control. If the gun pointing is erratic, all other efforts to reduce dispersion will be of little or no value.

b. Gun pointing is particularly important in the case of machine guns since one gunner points both laterally and vertically with a free mounted gun. The following steps must be taken to insure smooth tracking by machine gunners:

(1) Machine gunners are selected whose eyes are not sensitive to smoke, atmospheric conditions, flash, and glare. They must have the strength to manipulate readily the gun and

mount and should be mentally and physically well coordinated.

(2) The back rests and the distance of the gun trunnions above the ground should conform to the stature of the gunners. The gunners should also be provided with a firm and level footing.

(3) The gunners should receive training in the tracking of high speed aerial targets to accustom their muscles to function smoothly and instinctively during rapid movements in direction and elevation.

(4) The gunners should receive training in firing on high speed aerial targets to accustom them to the shock, smoke, and flash of firing and to the vibration of the mounts.

c. Gun pointing for the 37-mm gun, while not quite as important as in the case of machine guns, is still vital to the problem of dispersion. Gun pointers move the gun in azimuth and elevation by means of handwheels. The following steps must be taken to insure smooth tracking by the gun pointers:

(1) Gun pointers are selected whose eyes are not sensitive to smoke, atmospheric conditions, flash, and glare. They should be mentally and physically well coordinated.

(2) They should receive training in the tracking of high speed aerial targets to accustom them to the operation of the handwheels to accomplish rapid movements in direction and elevation.

(3) They should receive training in firing on high speed aerial targets to accustom them to the shock, smoke, and flash of firing and to the vibration of the carriages.

(4) The above remarks will also apply to the 40-mm gun when using forward area sights.

■ 41. VIBRATION OF MOUNT OR CARRIAGE.—*a.* The high rates of fire of caliber .50 machine guns and 37-mm and 40-mm guns causes the mount or carriage to vibrate continually while the gun is being fired. This vibration makes accurate gun pointing difficult.

b. (1) The vibration of the antiaircraft machine gun mount can be reduced appreciably by adjusting the rate of fire of the gun by means of the oil buffer as described in FM 4-135.

Each individual gun will be found to have its own cyclic rate at which vibration is least. This rate should be determined and then maintained.

(2) On the M2 mount a recoil mechanism is provided to reduce the vibration of the mount. Required adjustments to this mechanism are made as prescribed in FM 4-135.

c. The carriages for the 37-mm and 40-mm gun are much steadier than the machine gun mount. The only method of reducing vibration is to keep all moving parts in good operating condition and the length of recoil properly adjusted.

■ 42. VARIATION IN TIME OF FLIGHT.—*a. General.*—When firing at fixed or slowly moving targets, moderate variations in time of flight normally have only a minor effect on the fall of the shots. However, as the target speed is increased, the resulting dispersion becomes more serious and causes the cross-section of the cone of fire to change from a circle to an ellipse with the longer axis in the direction of flight of the target. This can best be illustrated by a problem. Consider a target moving at right angles to the line of fire at 150 yards per second. Assume that two bullets were fired at this target at the same instant and that one of them took 0.10 second longer to reach the target than the other. (Such an assumption is reasonable. A difference in time of flight of 0.10 second is caused at midrange (1,000 yards) by a variation in muzzle velocity of 170 feet per second.) During this 0.10 second the target will have moved 15 yards. Assuming that these two bullets would have struck the same vertical line in a stationary target, they will make holes 15 yards apart in the target traveling at 150 yards per second. On most automatic weapon targets, both shots could not have been hits. When a series of shots is fired at normal rates, this dispersion is apparent to the adjusters and spotters, causing a widening of the cone of fire and resulting in poor observation and adjustment of fire.

b. Variations from round to round.—(1) Variations in time of flight from round to round of a particular type and lot of ammunition are caused principally by slight differences in the rounds, which cause variations in the developed muzzle velocity. These differences may be of considerable magnitude.

Tests of the velocities of 10 shots fired consecutively from a single caliber .50 machine gun barrel have shown variations of more than 100 feet per second.

(2) Small differences in the time of flight of ball and tracer ammunition also exist at most ranges. Complete data on these differences are not available at this time. Present practice is to disregard the differences in these two types of ammunition. This problem applies only to machine guns, since all 37-mm or 40-mm antiaircraft ammunition is tracer ammunition.

(3) Round to round variations in muzzle velocity, both within types and between ball and tracer, are a characteristic of the ammunition and cannot be corrected for by the using personnel.

c. Variations among guns.—(1) Differences in time of flight among guns are caused chiefly by differences in the muzzle velocities developed by the individual barrels of those guns. For a particular barrel and ammunition the muzzle velocity depends mainly upon the amount that the bore has been eroded, particularly that portion at the breech end of the barrel. Due to the high rate of fire of antiaircraft automatic weapons, the barrels erode rapidly. For example, available data indicate that, under average conditions of firing, the barrel of a caliber .50 M2 machine gun will be eroded sufficiently to cause a loss of approximately 200 feet per second in muzzle velocity by the time that 3,000 to 3,500 rounds have been fired. At the maximum rate of fire (600 rounds per minute) this represents only 5 to 6 minutes of continuous fire. Similarly, erosion in the barrel of a caliber .30 machine gun causes a loss of about 160 feet per second in muzzle velocity by the time 5,000 rounds have been fired. This represents 9 to 11 minutes of continuous fire. Data on erosion of the 37-mm guns are limited, but loss in muzzle velocity appears to be negligible during the first 1,000 rounds, although after about 1,200 rounds have been fired loss in muzzle velocity increases rapidly.

(2) (a) The best method for determining the loss of muzzle velocity of machine-gun barrels is to gage the advance of the forcing cone and the wear of lands at the breech. Breech bore gages have been developed for both caliber .30

and caliber .50 machine guns but normally are not issued to antiaircraft artillery units. However, bullet seating gives a fair approximation of this gaging and therefore of the muzzle velocity to be expected.

(b) A simple gage for determining bullet seating may be made by fastening a stiff wire or rod to the base of a bullet of the proper caliber. Insert the bullet in the breech of a new barrel and scribe a mark on the rod or wire flush with the face of the breech. Mark this point 1.9 inches for the caliber .30 gage and 3.0 inches for the caliber .50 gage. With this mark as a starting point, lay off on the rod or wire a scale graduated in tenths of an inch, continuing the scale outward 1.5 inches (caliber .30) or 4.0 inches (caliber .50) from the mark. Each inch line should be marked to show the number of inches from the rear face of the bullet to that line. The wear of a barrel is then determined by dropping the gage into the breech end of the bore and reading the value on the scale at the point flush with the rear end of the barrel.

(c) Where no gage (manufactured or improvised) is available, a loose bullet may be carefully dropped, point first, into the breech end of the barrel and the distance from the rear face of the bullet to the rear face of the barrel then measured while the barrel is held vertically with the breech up. The bullet should always be dropped the minimum distance possible, and care should be taken to avoid pressing on the bullet when measuring the bullet seating.

(d) Having determined the bullet seating of a barrel, the chart in figure 1 is entered to obtain the variation in muzzle velocity which may be expected. For example, a reading of 5.5 inches' bullet seating for a 45-inch caliber .50 barrel indicates a muzzle velocity of about 90 foot/seconds below firing table MV and of about 190 foot/seconds below that of a new barrel. Similarly a reading of 2.5 inches' bullet seating for a caliber .30 barrel indicates a muzzle velocity of about 50 foot/seconds below firing table MV and of about 150 foot/seconds below that of a new barrel.

(e) So far as the question of dispersion is concerned, as long as all barrels of a fire unit show approximately the same amount of wear, variation in muzzle velocity from stand-

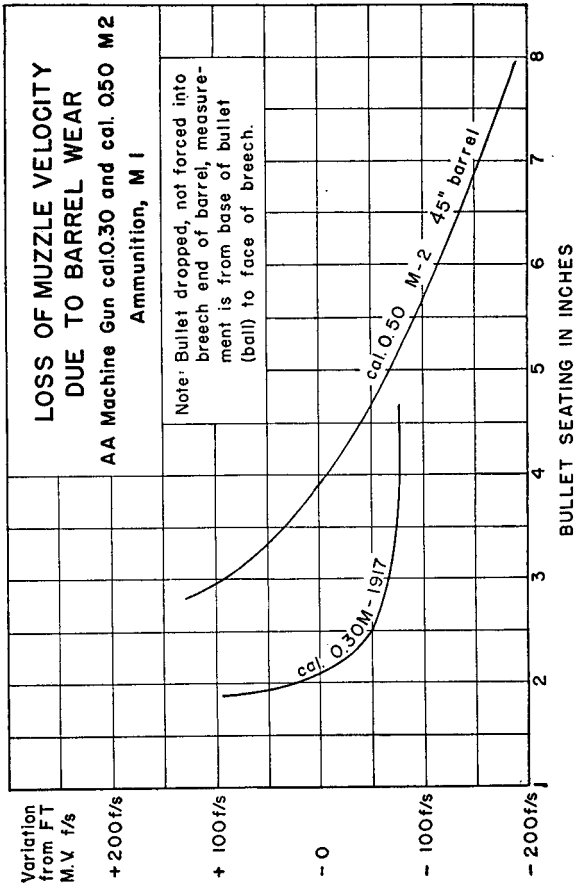

FIGURE 1.—Loss of muzzle velocity due to barrel wear.

ard will have little effect as the guns will still shoot together. (See ch. 5 for the effect on computed leads.) This desirable condition can be maintained by frequently checking bullet seating and matching the barrels in sets having approximately the same bullet seating. An examination of the curves in figure 1 shows that to keep the muzzle velocities of the different barrels within about 50 feet per second of each other, the values of bullet seating should be within 1 inch of each other for caliber .50 machine guns and 0.5 inch of each other for caliber .30 machine guns.

(3) In the case of the 37-mm antiaircraft gun, no tested method of determining tube (barrel) erosion employable by using personnel has been developed. Therefore an attempt should be made, when practicable, to fire the guns so that the total number of rounds fired will be approximately the same for both guns of the fire unit. This should give approximately uniform wear for both guns since the rate of fire is not as variable as, and is much lower than, that of machine guns.

■ 43. SPREADING THE GUNS.—*a.* When used in connection with antiaircraft automatic weapons, the term "spreading the guns" means the adjusting of the sighting systems of fire unit so that when certain leads are set on the control box lead dials, the corresponding leads set on the gun sights will vary slightly from gun to gun. For example, in a machine gun platoon with the lateral lead dial of the control box set at normal (see par. 26), the lateral leads for guns Nos. 2 and 3 might be 0; that for gun No. 1, plus 2; and that for gun No. 4, minus 2. Similar spreading vertically can be accomplished.

b. The purpose of spreading the guns is to enlarge the cone of fire so as to increase the volume of the space in which hits can be expected.

c. There are three important reasons why spreading the guns is unsound.

(1) Effective fire from automatic weapons can be obtained consistently only when the maximum possible volume of fire is placed on the target. Even under ideal conditions, the dispersion of automatic weapons fire at moving targets is such as to permit only a small percentage of hits on the

target. Spreading the guns will increase this dispersion still further, resulting in even fewer hits.

(2) The enlargement of the cone of fire will increase the difficulty of observing and adjusting fire. This will normally result in an additional reduction in the percentage of hits obtained.

(3) Although spreading of the guns can usually be accomplished during target practice, it cannot be successfully accomplished, so far as lateral leads are concerned, under service conditions. The guns are intended for use in all-around fire. Guns spread laterally at one point are correspondingly converged if they are traversed 3,200 mils. Therefore, the spreading of the guns is accomplished for only a part of the field of fire.

■ 44. SYNCHRONIZATION OF FIRE-CONTROL SYSTEM.—*a.* The synchronization of the fire-control system (central control only) is the adjustment necessary to insure that the desired lateral and vertical leads, when set on the control box, will be set on each gun. This synchronization must be performed each time the matériel is set up in firing position. When the matériel is in position for some time, the synchronization is performed daily, or more often if necessary.

b. The first step in synchronization of the system is the adjustment of the control box. To accomplish this, the control box having been set up, turn the adjusting knobs until the lead adjusting indexes read zero. When this has been done, see that the lead indexes are at normal (300 for machine gun units, 500 for 37-mm gun units). If they are not, remove the covers from the input couplings and rotate the couplings until the lead indexes are properly set. Then replace the coupling covers, checking to see that the lead adjusting indexes and lead indexes have not been moved. After the adjustment is completed, the coupling covers must not be removed unless specifically authorized. Set the transmitted lead indexes at normal by turning the lead hand-wheels.

c. The second step in the synchronization is the hooking up of the flexible shafts. The control box having been adjusted as described in *b* above and the guns bore sighted as

described in FM 4-135 (machine guns) or FM 4-140 (37-mm guns), hook up the required number of flexible shafts from the output couplings of the control box to the corresponding couplings (lateral or vertical) of the sighting systems (see *b* above).

d. When the system has been connected, set various leads on the lead dials of the control box and check them against the readings of the counters on the sighting system of the guns. At least one reading on each side of normal should be checked for both the lateral and vertical sight mechanisms.

e. (1) If the readings checked as described in *d* above agree in each case, the synchronization of the system is completed.

(2) If the readings of one of the counters are consistently in error by a few mils plus or minus, the system must be resynchronized. To do this, return the corresponding lead index (lateral or vertical) of the control box to its normal reading and remove the flexible shaft from the coupling of the part of the sight mechanism to which the counter is attached. Recheck the bore sighting, making the necessary adjustments as described in FM 4-135 or FM 4-140. When the system is again connected recheck the synchronization as described in *d* above.

(3) If, after the system is connected, one of the counters fails to turn when the corresponding lead handwheel is operated, some part of the sight mechanism is probably broken or damaged. In this case it will usually be found that the flexible shaft is broken. Return all parts of the system to normal, replace the flexible shaft with a new shaft, and recheck the synchronization as described in *d* above.

f. (1) The vertical lead flexible shafts may be broken if an attempt is made to turn the vertical lead handwheel on the control box so as to set a positive vertical lead on the gun sights when the 37-mm gun is depressed below about 15°. Therefore, before the cables are connected to a gun sighting system, be sure that the gun is elevated above 15°. Thereafter, *keep the guns elevated above 15° whenever the system is connected except when they are depressed for a specific purpose, in which case care must be taken to insure that the*

control box is not operated. This precaution is necessary because when the gun is depressed to zero, the sights can be depressed only about 50 additional mils before they hit the sight brackets. This precaution does not apply to the M2 machine-gun mount.

(2) (a) Even though the 37-mm guns are partly elevated, if the gun sighting systems were to be connected to the control box when the vertical counter on a sighting system has a reading which differs considerably from that of the vertical lead index of the control box, an extreme vertical lead may later be set on the sighting system resulting in the same difficulty as described in (1) above.

(b) Under similar conditions, the front sight of the M2 machine-gun mount may be damaged at any angle of elevation.

(c) Therefore, always insure that the lead counters or indexes on the sighting systems and the indexes on the control box are at the same readings before hooking up the flexible shafts.

(3) Forcing of lead handwheels may cause damage to the control set or to the sight mechanism. Pointer matchers must be cautioned never to put excessive pressure on the lead handwheels. If a handwheel is hard to turn, they must stop and determine the cause. Possible causes are sights or the transmitted lead indexes coming up against a stop, accumulation of dirt blocking the movement of the sight, kinked flexible shaft, or burs on gears of the control box.

SECTION II

HIT EXPECTANCY

■ 45. TEST OF DISPERSION OF FREE MOUNTED GUN.—*a.* To determine the minimum dispersion (maximum percentage of hits) to be expected with a free mounted automatic weapon, tests have been conducted with a caliber .50 machine gun, mounted on an M2 mount, firing on a stationary target. The hits obtained on the target and on the B9 silhouette may be summarized as follows:

Range in yards	Percent holes in target	Percent hits on B9 silhouette
800.....	98	43.8
1,300.....	70	20.0
1,800.....	50	10.6

b. The percentage of holes in the various parts of the target were not in accordance with the distribution which could be expected from the laws of probability. This was probably due to the constant shifting in the point of aim that a free mounted gun will always produce when firing. Experience has shown that an experienced machine gunner firing a caliber .50 machine gun can barely keep a high speed target in view in ring sight that subtends 10 mils, which indicates that the total dispersion of gun pointing is about 10 mils. This minimum error represents 3 yards at 300 yards' range, 6 yards at 600 yards' range, and 18 yards at 1,800 yards' range.

c. The number of rounds per unit of area within the cone of fire at 1,800 yards is $\frac{1}{9}$ of that at 600 yards and $\frac{1}{36}$ of that at 300 yards. This clearly indicates that the percentage of hits should decrease markedly as the range is increased. This assumption is supported by the test described in *a* above.

■ 46. RELATIVE FREQUENCY OF HITTING Laterally AND VERTICALLY.—Accurate data are lacking on whether most shots from automatic weapons miss the target laterally or vertically. Such factors as variations in the rate of change of leads, reversal of rates from increasing to decreasing (or from decreasing to increasing), relative ability of the lateral and vertical adjusters and pointer matchers at the control box, the speed of the target, the shape of the cone of fire, and the shape of the vulnerable area of the target complicate the problem. A reliable answer to the question cannot be given until the results of a number of complete dispersion tests against fast-moving targets are available.

■ 47. RELATION OF REMAINING VELOCITY TO TIME OF FLIGHT.—Figure 2 shows the rapidity with which a 37-mm projectile

loses velocity. At 3 seconds' time of flight the velocity of a 37-mm projectile has dropped to 1,300 foot-seconds from an initial muzzle velocity of 2,500 foot-seconds. At 5 seconds it has dropped to approximately 1,050 foot-seconds. Figure 2 illustrates that, with a given muzzle velocity, time of flight is not only a function of range but also a function of the remaining velocity of the projectile. Thus, it can be understood that the more effective fire must be restricted to the very short times of flight.

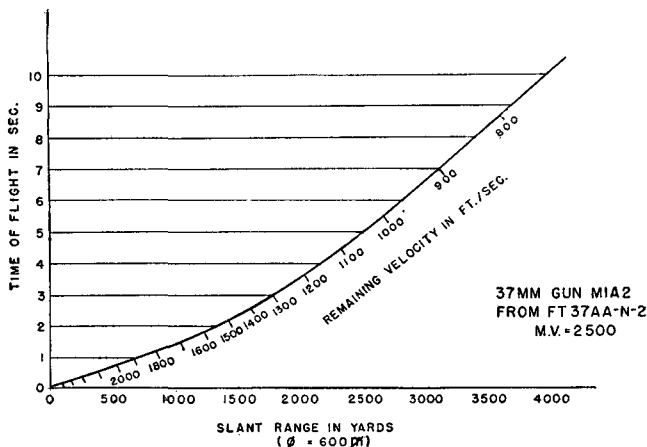

FIGURE 2.—Relation of remaining velocity to time of flight.

CHAPTER 3

CALCULATION OF LEADS

	Paragraphs
SECTION I. Elements of data.....	48-53
II. Firing tables.....	54-57
III. Methods of lead calculation.....	58-64

SECTION I

ELEMENTS OF DATA

■ 48. GENERAL.—*a.* An analysis of gunnery for antiaircraft automatic weapons includes careful study of leads and their characteristics for representative type target courses and speeds. This is true whether forward area sights, computing sights, tracer control, oriented charts for dive targets, or director control is the means of fire control.

b. If the fire of antiaircraft automatic weapons is to be successfully adjusted by observation of tracers, the tracer stream must be kept at least in the immediate vicinity of the target. To accomplish this, approximately correct leads must be continuously applied to the guns. Since no satisfactory lead computer is at present available (except in the case of director-controlled automatic weapons) for determining the leads which should be applied to the guns, dependence must be placed on the estimation of leads both for determining initial leads and for anticipating the rates of change in the required leads throughout the course of the target. These changes in the leads are at rates which vary constantly during the course. Leads must be calculated for use in constructing lead charts in order to enable personnel responsible for the application of these leads to become familiar with the approximate leads required for various types of target courses.

c. Only target courses which are rectilinear and are flown at constant speeds can be calculated readily. These courses are divided, with respect to the target's course and the gun position, into two general types, coming courses and crossing courses. Each of these types of courses is further subdivided into constant altitude courses and diving courses. The

method of calculating leads for courses in each of these classifications is discussed separately in section III.

d. In this text all calculations of leads for crossing courses are based on left to right courses, and all lateral leads are right leads. The data for right to left courses are calculated and plotted in the same manner, in which case all lateral leads would be left leads.

■ 49. COMING-CONSTANT ALTITUDE COURSE.—A typical set-up in the vertical plane for a coming-constant altitude course is given in figure 3. This figure shows the basic elements of data for such a course and should be thoroughly understood before proceeding with the computation of leads. (For the prescribed symbols used with anti-aircraft automatic weapons see appendix I.)

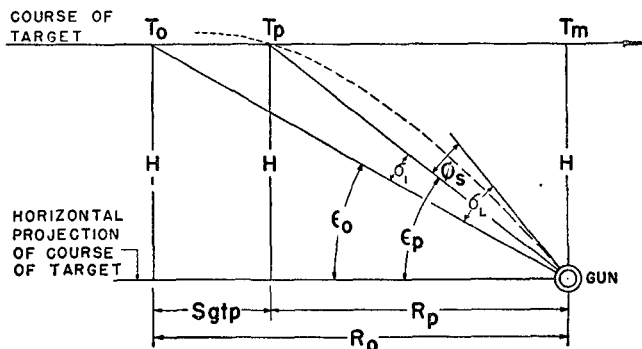

- ϵ_0 Angular height of target at present position (T_0).
- ϵ_p Angular height of target at future position (T_p).
- H Altitude of target.
- ϕ_s Superelevation under firing table conditions.
- R_0 Horizontal range to target at present position (T_0).
- R_p Horizontal range to target at future position (T_p).
- S_g Ground speed of target.
- $S_g \times t_p$ Linear horizontal travel of target during time of flight.
- T_m Midpoint—position of target where $\epsilon = 90^\circ$.
- T_0 Present position of target (instant of firing).
- T_p Predicted position of target (future position).
- t_p Time of flight of projectile to future position of target (T_p).
- σ_1 Principal vertical lead angle.
- σ_L Vertical lead.

FIGURE 3.—Elements of data for coming-constant altitude course (vertical plane containing gun, T_0 , T_p , and T_m).

■ 50. COMING-DIVING COURSE.—A typical set-up in the vertical plane for a coming-diving course is given in figure 4. The basic elements are the same as those for a coming-constant altitude course except for the following:

Add γ Angle of dive.

For H substitute—

H_m Altitude of target at midpoint (T_m).

H_o Altitude of target at present position (T_o).

H_p Altitude of target at future position (T_p).

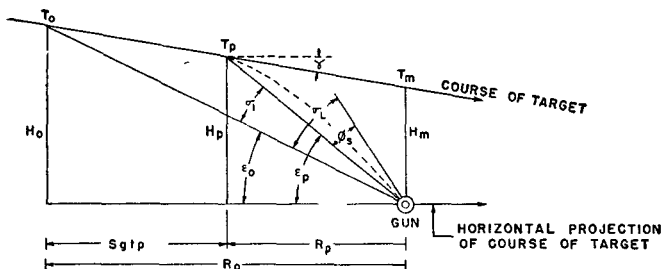

FIGURE 4.—Elements of data for coming-diving course (vertical plane containing gun, T_o , T_p , and T_m).

■ 51. CROSSING-CONSTANT ALTITUDE COURSE.—A typical set-up in space for a crossing-constant altitude course, showing the basic elements of data, is given in figure 5.

■ 52. CROSSING-DIVING COURSE.—A typical set-up in space for a crossing-diving course is given in figure 6. The basic elements are the same as those for a crossing-constant altitude course, with the following exceptions:

γ Angle of dive, measured from the horizontal.

L_d Horizontal distance from present position of a dive target to the objective.

L_m Horizontal distance from the midpoint to the objective of a dive target.

For H substitute:

H_m Altitude of target at midpoint (T_m).

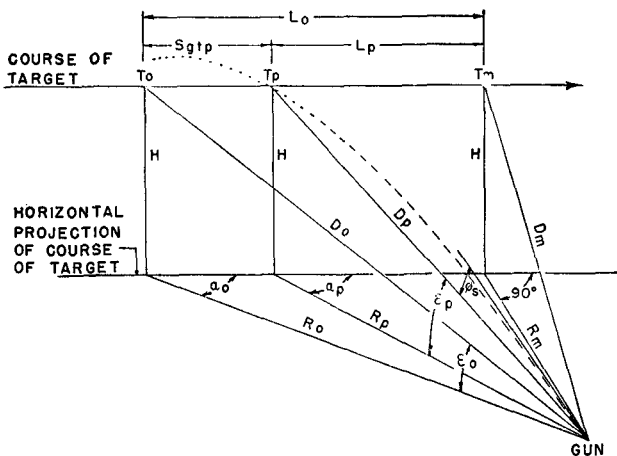

- α_o Angle of approach at present position of target (T_o).
- α_p Angle of approach at future position of target (T_p).
- D_{min} Minimum slant range. (For constant altitude courses $D_{min} = D_m$.)
- D_m Slant range to midpoint of course (T_m).
- D_o Slant range to target at present position (T_o).
- D_p Slant range to target at future position (T_p).
- ϵ_o Angular height of target at present position (T_o).
- ϵ_p Angular height of target at future position (T_p).
- H Altitude of target.
- L_o Distance from midpoint of course (T_m) to present position (T_o) in horizontal plane.
- L_p Distance from midpoint of course (T_m) to future position (T_p) in horizontal plane.
- ϕ_s Superelevation under firing table conditions.
- R_m Minimum horizontal range or horizontal range to target at midpoint of course (T_m).
- R_o Horizontal range to target at present position (T_o).
- R_p Horizontal range to target at future position (T_p).
- S_g Ground speed of target.
- $S_g \times t_p$ Linear horizontal travel of target during time of flight.
- T_m Midpoint—position of target where $\alpha = 90^\circ$.
- T_o Present position of target (instant of firing).
- T_p Predicted position of target (future position).
- t_p Time of flight to future position of target (T_p).

FIGURE 5.—Elements of data for a crossing-constant altitude course.

H_o Altitude of target at present position (T_o).

H_p Altitude of target at future position (T_p).

■ 53. DEFINITIONS AND SYMBOLS.—*a. Angle of approach* (α).—(1) Angle of approach is the acute horizontal angle between the plane of position and the vertical plane containing the course of the target (never greater than 90°).

(2) The symbol for the angle of approach at the present position of the target is α_o .

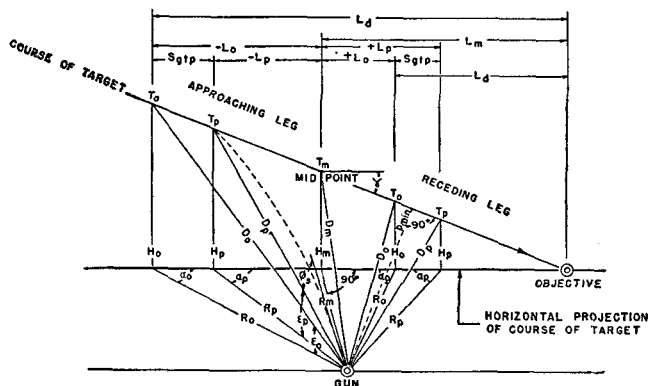

FIGURE 6.—Elements of data for crossing-diving course.

(3) The symbol for the angle of approach at the future position of the target is α_p .

(4) On a coming course, α is always zero.

(5) The gun-objective-target angle is the horizontal angle between the vertical planes containing the target's course and the gun-objective line.

b. Target position (T).—(1) T designates the position of the target at some particular instant.

(2) The position of the target at the instant of firing is called the present position of the target and is represented by the symbol T_o .

(3) The position of the target at which it is predicted the projectile will meet the target is called the future position of the target and is represented by the symbol T_p .

(4) The position of the target when the angle of approach equals 90° is called the midpoint of the course and is represented by the symbol T_m . On coming courses, T_m is directly over the gun, that is, ϵ equals 90° .

c. Slant range.—(1) Slant range is the distance from the gun to the target measured along the line of position.

(2) The slant ranges to each of the positions of the target, T_o , T_p and T_m , are represented by the symbols D_o , D_p , and D_m , respectively.

(3) D_{min} is the symbol for the minimum slant range to the target. In constant altitude courses the minimum slant range is at the midpoint of the course, and $D_{min}=D_m$.

d. Horizontal range (R).—(1) Horizontal range is the distance from the gun to the projection of the target position in the horizontal plane.

(2) The horizontal ranges to each of the positions of the target, T_o , T_p , and T_m , are represented by the symbols R_o , R_p , and R_m , respectively.

(3) On coming courses R_m is equal to zero.

e. Angular height (ϵ).—(1) Angular height is the vertical angle measured from the horizontal to the line of position.

(2) The angular heights to T_o and T_p are represented by the symbols ϵ_o and ϵ_p , respectively.

f. Altitude (H).—(1) Altitude is the vertical distance to the target from the horizontal plane through the gun.

(2) The altitudes to each of the positions of the target, T_o , T_p , and T_m are represented by the symbols H_o , H_p , and H_m , respectively.

(3) For constant altitude courses $H_m=H_o=H_p$, and the altitude is represented by the symbol H .

(4) For diving courses—

$$H_o=H_m \pm (L_o \tan \gamma) \text{ (crossing)}$$

$$\text{or } H_o=H_m \pm (R_o \tan \gamma) \text{ (coming).}$$

$$H_p=H_m \pm (L_p \tan \gamma) \text{ (crossing)}$$

$$\text{or } H_p=H_m \pm (R_p \tan \gamma) \text{ (coming).}$$

g. Horizontal distance along course (L).—(1) The horizontal distance from the midpoint (T_m) to the present position of the target (T_o) is represented by the symbol L_o .

(2) The horizontal distance from the midpoint (T_m) to the future position of the target (T_p) is represented by the symbol L_p .

(3) The horizontal distance from the midpoint (T_m) to the objective of a dive target is represented by the symbol L_m .

(4) The horizontal distance from the present position of a dive target (T_o) to the objective is represented by the symbol L_d .

NOTE.—Values of L_o and L_p are considered plus when measured in the direction of flight and minus when measured in the opposite direction.

h. Superelevation (ϕ_s).—(1) Superelevation is that part of the quadrant elevation which compensates for the curvature of the trajectory. It is the amount that the axis of the bore must be pointed above the line of position to the future position of the target (T_p) in order that the trajectory will pass through the target at that point. Values of superelevation are obtained from firing tables.

(2) Superelevation is *always* a plus value and is added algebraically to the principal vertical lead angle to obtain the vertical lead.

*i. Time of flight (t_p).—*Time of flight is the elapsed time in seconds for the projectile to travel from the gun to the future position of the target (T_p). It is represented by the symbol t_p .

j. Ground speed (S_g).—(1) The ground speed of the target is the velocity of the target with respect to the ground. It is measured by determining the rate of travel in the horizontal plane of the projection of the target in that plane. In calculation it is always expressed in yards per second. Miles per hour divided by two represents yards per second with sufficient accuracy for calculation. Ground speed is represented by the symbol S_g .

(2) The symbol for speed of the target along its path is S . It may be expressed in miles per hour or in yards per second.

(3) For diving courses, $S_g = S \cos \gamma$.

*k. Lateral lead (δ_L).—*Lateral lead is the angle in the slant plane of the lateral sight by which the gun must lead the target to cause the projectile and target to meet. It is

the algebraic sum of the principal lateral lead angle (δ_1 and any necessary pointing correction (δ_2). The pointing correction (δ_2) is not considered in the calculation of leads. However, this correction does exist but it is included and applied by the adjuster. (This element of data is not shown in figs. 7 and 8.)

l. Vertical lead (σ_L).—Vertical lead is the angle by which the gun must lead the target vertically in order that the projectile will meet the target at the future position. It is measured in the vertical plane containing the axis of the bore of the gun and is the algebraic sum of the principal vertical lead angle (σ_1), the superelevation (ϕ_s), and any necessary pointing correction (σ_2). The pointing correction (σ_2) is not considered in the calculation of leads. However, this correction does exist but it is included and applied by the adjuster.

m. Principal lateral or vertical lead angle (δ_1 or σ_1).—(1) The principal lateral (or vertical) lead angle is the lead angle necessary to compensate for the travel of the target during the time of flight of the projectile.

(2) The principal lateral lead angle is represented by the symbol δ_1 .

(3) The principal vertical lead angle is represented by the symbol σ_1 .

n. Angle of dive (γ).—(1) Angle of dive is the vertical angle between the course of the target and the horizontal.

(2) The projection of the angle of dive on the vertical plane containing the gun and the future position of the target (T_p) is represented by the symbol γ_v .

SECTION II

FIRING TABLES

■ 54. GENERAL.—*a.* Firing tables are used to determine time of flight (t_p) and superelevation (ϕ_s) for the future position of the target in computing leads. A discussion of these tables therefore properly belongs in a study of lead calculation.

b. In addition to their use in determining t_p and ϕ_s , firing tables are employed to determine differential effects of varia-

tions from the standard conditions on which the firing tables are based and other trajectory data.

c. (1) The standard conditions on which firing tables are based are—

(a) Muzzle Velocity (MV)—as listed in the table.

(b) Wind—none.

(c) Air density at the battery—that for a temperature of 59° F., a barometric reading of 29.53 inches of mercury, and air saturation of 78 percent (525.9 grains per cubic foot).

(d) Air temperature at the battery—59° F.

(e) Powder temperature—70° F.

(f) A standard atmospheric structure aloft is assumed; that is, atmospheric temperature and density vary with altitude in a particular manner.

(2) Variations from these assumed conditions will affect the behavior of the projectile. In firing tables for anti-aircraft automatic weapons, these variations from standard conditions are listed in terms of their effects on superelevation and time of flight, except in the caliber .30 tables, where the effects are given in terms of range, altitude, and angular height.

d. A list of the standard firing tables pertaining to a particular weapon will be found in the Standard Nomenclature List published by the Ordnance Department.

■ 55. CONTENTS OF FIRING TABLES.—The present standard firing tables are published in book form. The first section (introduction) contains general information pertaining to the gun and projectile, and a detailed explanation of the tables and of the meteorological message. Subsequent parts of the tables give the following data:

a. Trajectory data (horizontal range, altitude, angular height, and superelevation), using quadrant elevation and time of flight as arguments.

b. Time of flight and superelevation, using horizontal range and altitude (and, in addition, in firing tables for the 37-mm or 40-mm guns, slant range and angular height) as arguments.

c. (1) Differential effects on superelevation and time of flight due to 100 f/s decrease in muzzle velocity, 10 percent

decrease in density, and 10 mph rear wind, using horizontal range and altitude as arguments.

(2) Differential effects on lateral lead due to 10 mph cross wind, using horizontal range and altitude as arguments.

d. In each firing table, a trajectory chart is included. This chart shows in graphical form the relationship of altitude and horizontal range, quadrant elevation, time of flight, and angular height.

■ 56. DETERMINATION OF TIME OF FLIGHT AND SUPERELEVATION.—*a.* Time of flight and superelevation under standard firing table conditions are normally extracted from the firing tables, using R_p and H_p (or H) as arguments. In the case of tables for the 37-mm or 40-mm guns, D_p and ϵ_p may also be used as arguments, the choice of arguments to be used being dictated by convenience. For example, since time of flight is virtually constant for a certain slant range, regardless of angular height, tedious interpolation may often be eliminated by using D_p and ϵ_p as arguments to extract t_p . In either case, however, values obtained should be the same.

b. (1) Having selected the proper table, the procedure is to read under the correct value of altitude (or angular height) and opposite the correct value of horizontal (or slant) range the time of flight in seconds (or superelevation in mils).

(2) Example: What are the superelevation and time of flight under standard conditions for the points ($H_p=800$, $R_p=1,000$) and ($\epsilon_p=500$, $D_p=1,200$), when firing a 37-mm gun M1A2, using fixed HE shell M54? (Use FT 37-AA-N-2.)

(*a*) Entering table Ib, opposite 1,000 yards horizontal range and under 800 yards altitude is found the time of flight, 1.95 seconds.

(*b*) Entering table Ic, opposite 1,000 yards horizontal range and under 800 yards altitude is found the superelevation, +13.4 mils.

(*c*) Entering table Id, opposite 1,200 yards slant range and under 500 mils angular height is found the time of flight, 1.79 seconds.

(*d*) Entering table Ie, opposite 1,200 yards slant range and under 500 mils angular height is found the superelevation, +13.8 mils.

Tabulation

Given	Tables used	t_p (sec)	ϕ_s (mils)
$H_p=800$	} Ib and Ic.....	1.95	+13.4
$R_p=1,000$			
$E_p=500$	} Id and Ie.....	1.79	+13.8
$D_p=1,200$			

■ 57. CORRECTIONS FOR VARIATIONS FROM STANDARD CONDITIONS.—*a.* Where it is desired to obtain superelevations and times of flight corrected for nonstandard conditions, it is necessary to add algebraically to the superelevation and time of flight for standard conditions the corrections for the effects of the variations from standard conditions as shown in the firing tables.

b. Following is an example of the proper method to employ in obtaining corrected superelevation and time of flight for a particular point in space when firing a 37-mm gun M1A2, using fixed HE shell M54, under nonstandard conditions.

Given: Determine data for the point $R_p=1,800$ yards, $H_p=600$ yards. Assume nonstandard conditions:

Developed muzzle velocity..... 2,600 f/s.
 Air density..... 95 percent.
 Rear wind..... 30 mph.
 Cross wind..... 30 mph (right to left).

The firing table to be used is FT 37-AA-N-2, which is based on a muzzle velocity of 2,500 f/s. Note that the values given in the differential effects tables are effects and not corrections.

Solution:

(1) *Muzzle velocity.*—(*a*) The developed muzzle velocity is 100 f/s greater than standard. Turn to table IIa in the firing tables. This table is for the effect on superelevation of a decrease in muzzle velocity of 100 f/s. To obtain the effect of a 100 f/s increase in muzzle velocity, reverse the sign of the effect.

(b) Entering the table, opposite 1,800 yards horizontal range and under 600 yards altitude, the value -2.5 mils is obtained. Changing the sign as mentioned above, the effect on superelevation of an *increase* of 100 f/s in muzzle velocity at the point selected becomes $+2.5$ mils. Enter this value in the tabulation below.

(c) In a similar manner enter table IIb to obtain the effect of the assumed muzzle velocity on time of flight. The value (with sign changed as above) is $+0.15$ second. Enter this value in the tabulation.

(2) *Air density.*—(a) Turning to tables IIc and IId, they are found to show the effects for a decrease in air density of 10 percent. The assumed air density is 95 percent or a decrease from normal of 5 percent. Therefore, the effects taken from tables IIc and IId will be correct in sign but must be divided by two to obtain the required value.

(b) Enter table IIc. Opposite 1,800 yards horizontal range and under 600 yards altitude is the value $+1.5$ mils. Dividing this by two, the effect on superelevation of the assumed air density is found to be $+0.8$ mil. Enter this value in the tabulation.

(c) In a similar manner the value $+0.07$ second is obtained from table IId as the effect on time of flight of the variation in air density. Enter this value in the tabulation.

(3) *Rear wind.*—(a) Turning to tables IIe and IIIf, they are found to show the effects for a rear wind of 10 mph. Since the assumed rear wind is 30 mph the values found in the tables must be multiplied by three to determine effects of a rear wind of this velocity.

(b) Enter table IIe. Opposite 1,800 yards horizontal range and under 600 yards altitude is found the value -0.7 mil, which is the effect on superelevation of a rear wind of 10 mph. This value is multiplied by three and the product, -2.1 mils, entered in the tabulation.

(c) In a similar manner the value $+0.03$ second is obtained from table IIIf as the effect on time of flight of the variation in rear wind. Enter this value in the tabulation.

Tabulation			
Assumed condition	Tables used	Effects on	
		ϕ_s (mils)	t_p (seconds)
+100 f/s, MV.....	IIa, IIb.....	+2.5	+0.15
-5 percent density.....	IIc, IId.....	+0.8	+0.07
30 mph rear wind.....	IIe, IIf.....	-2.1	+0.03
Total effects.....		+1.2	+0.25
		ϕ_s (mils)	t_p (seconds)
Data under standard conditions.....		+26.1	+3.28
Total corrections for nonstandard conditions.....		-1.2	-0.25
Corrected data.....		+24.9 or +25	+3.03

(4) *Correction for cross wind.*—(a) In table IIg the effect of cross wind on the lateral lead is given directly in mils. The table is made up for a cross wind of 10 mph. For a cross wind of 30 mph the value taken from the table must be multiplied by three to determine the effect of a cross wind of this velocity.

(b) Entering the table opposite 1,800 yards horizontal range and under 600 yards altitude, the effect on lateral lead is found to be 7.8 mils (without sign). Since the wind is from right to left, the trajectory is moved to the left, the effect is L 7.8 mils, and the correction is R 7.8 mils. If the computed lead is in reference numbers such as appear on the lead dials of the control box, the correction is added algebraically to it. In cases where leads are given as left or right by the actual number of mils, the correction would be subtracted from a left lead and added to a right lead.

c. (1) Under service conditions it will be impracticable to determine corrections for nonstandard conditions for the specific course to be fired on. However, if the lead values for points on type courses have been computed previously, both for standard conditions and selected nonstandard conditions, and lead curves plotted to show the relationships of

these leads, an estimate of the approximate average change in leads required as the result of a specific nonstandard condition can be made.

(2) Wind corrections normally are not practicable for a crossing course as the wind components vary continuously throughout the course at a rapid rate. Possible exceptions are courses at the longer ranges, particularly those which approximate coming courses.

SECTION III

METHODS OF LEAD CALCULATION

■ 58. GENERAL.—*a.* Antiaircraft automatic weapons pointed by central control use sights to point the gun in elevation and direction. The sight is mounted directly on the gun or carriage and traverses and elevates with the gun. Application of the required leads is accomplished by shifting the line of sight (of the sight) from a line parallel to the axis of the bore by an angular amount equal to the required leads. The shifting of the line of sight is done by means of tangent screws or by rotating the sighting elements.

b. Leads must be calculated for the future position of the target (T_p) where t_p and ϕ_s are applicable. Future positions are selected at convenient distances along the course of the target (usually in even hundreds of yards to facilitate use of the firing tables), and from them the corresponding present positions as well as the leads are calculated.

■ 59. DEFINITIONS OF LEADS.—*a. Positive lateral leads.*—(1) A positive (+) lateral lead is one where the gun points ahead of the target.

(2) An increasing positive (+) lateral lead is one where the gun continues to point farther ahead of the target with each succeeding increment of time.

(3) A decreasing positive (+) lateral lead is one where the gun (pointing ahead of the target) continues to point closer to the target with each succeeding increment of time.

b. Negative lateral leads.—These are leads in which the gun points behind the target. Naturally, they are never used in the automatic weapons gunnery problem whether increasing, decreasing, or static.

c. Positive vertical leads.—(1) A positive (+) vertical lead is one where the gun points above the target.

(2) An increasing positive (+) vertical lead is one where the gun continues to point farther above the target with each succeeding increment of time. (It is rarely obtained in automatic weapons fire.)

(3) A decreasing positive (+) vertical lead is one where the gun (pointing above the target) continues to point closer to the target with each succeeding increment of time.

d. Negative vertical leads.—(1) A negative (−) vertical lead is one where the gun points below the target.

(2) An increasing negative (−) vertical lead is one where the gun continues to point farther below the target with each succeeding increment of time.

(3) A decreasing negative (−) vertical lead is one where the gun (pointing below the target) continues to point closer to the target with each succeeding increment of time.

e. Zero vertical leads.—A zero vertical lead occurs when a decreasing positive lead changes to an increasing negative lead.

■ 60. DATA REQUIRED FOR CALCULATION OF LEADS.—*a.* To calculate leads for a course, the following basic data are assumed:

- (1) Minimum horizontal range or range to midpoint (R_m).
- (2) Altitude at midpoint (H_m).
- (3) Ground speed of target (S_g).
- (4) Various future positions of the target (T_p) along the course are selected by assuming values of L_p or R_p .
- (5) Angle of dive (γ).

b. In addition, certain data are extracted from firing tables:

- (1) Time of flight to future position (t_p).
- (2) Superelevation to future position (ϕ_s).

■ 61. COMING-CONSTANT ALTITUDE COURSES.—*a.* In the computation for coming courses, there are no lateral leads, since the angle of approach of the target is 0. Only the vertical leads are computed.

b. Although the only true coming courses are those where the target comes directly toward the gun position

($R_m=0$), all crossing courses with an R_m less than 100 yards are considered to be coming courses. The lateral leads are small until the target is very close and then they change so rapidly that even if a gun could follow the target, it would be impossible to transmit the rapidly changing lead to the sights. Also the vertical leads for these courses are prac-

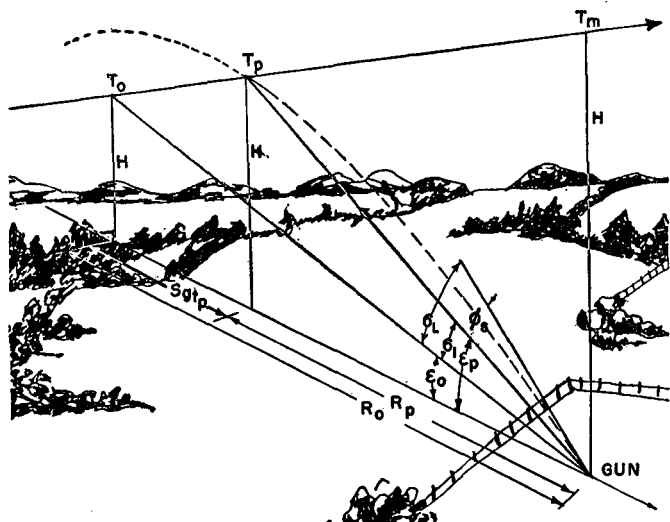

FIGURE 7.—Vertical lead, coming-constant altitude course.

tically the same as for a true coming course of the same altitude and speed.

c. Figure 7 represents the pictorial view of the approaching leg of a coming-constant altitude course. The formula for vertical lead for a true coming-constant altitude course is—

$$\sigma L = \epsilon_p - \epsilon_o + \phi_s.$$

Referring to figure 7, it is obvious that the lead necessary to cause the projectile to meet the target at T_p is merely the angular difference between ϵ_o and ϵ_p , added algebraically to the superelevation. Note that the principal vertical lead

angle ($\epsilon_p - \epsilon_o$, or σ_1) is always positive on the approaching leg of a coming-constant altitude course, and is always negative on the receding leg of such a course. Superelevation is always positive.

d. (1) To compute the leads for a type course, the altitude and ground speed of the target are assumed, and various future positions of the target are selected in terms of R_p . The maximum value of R_p on either the approaching or receding leg will depend on the maximum range of the armament. Leads may be calculated at 100- to 400-yard increments, depending upon the maximum range and desired accuracy for plotting the lead curve. The approaching leg and receding leg may be calculated on one form, using a large increment for R_p , or a small increment may be used to compute only the approaching or receding leg. The computation for each selected future position then consists of determining the following:

- ϵ_p from R_p and H .
- R_o from R_p and Sgt_p .
- ϵ_o from R_o and H .
- σ_L from ϵ_p , ϵ_o , and ϕ_s .

NOTE.—If corresponding values of R_p on the approaching leg and on the receding leg are selected, the work required to determine ϵ_p , t_p , and ϕ_s will be reduced.

(2) The above computations can be rapidly performed by using the M1 (Crichlow) slide rule. Calculation Form No. 1 (*f* below) is a convenient form for use when this slide rule is employed.

e. To calculate the vertical lead:

(1) Enter the selected values of R_p on line 1 of the form.

(2) Extract from the proper firing tables the times of flight and the superelevations for each selected future position, using H and R_p as arguments. Enter the times of flight (nearest hundredth of a second) and the superelevations (nearest mil) on lines 3 and 8, respectively, of the form.

(3) Multiply each time of flight by the assumed ground speed in yards per second and enter the results (to the nearest yard) on line 4. It may be desired to perform the multipli-

cation of S_g and t_p on the M1 (Crichlow) slide rule. Set the long arm (L) to the assumed S_g in yards per second on scale E, and move the short arm (S) to the index of scale E. Without changing the angle between the arms, shift (L) until (S) is set to the first time of flight on scale E and read under (L) the value of $S_g t_p$ on scale E. Still without changing the angle between the arms, continue to set (S) to times of flight and read values of $S_g t_p$ under (L) for each R_p .

(4) Add to (approaching leg) or subtract from (receding leg) line 1 the values in line 4 to obtain values of R_o . Enter these values on line 5.

(5) Compute the values of ϵ_p for each selected future position, using the slide rule. Set long arm (L) on the larger value, R_p or H , on scale E, and set the short arm (S) on the smaller of the two values, R_p or H , on scale E. Without changing the angle between the two arms, move (L) until (S) is on the index of scale E, and read the value of ϵ_p under (L) on scale C. Note that scale C has two sets of readings. If H is less than R_p , read the smaller angle. If H is greater than R_p read the larger angle. Enter the values of ϵ_p on line 2 of the form.

(6) Compute the value of ϵ_o for each present position corresponding to a selected future position, using the slide rule. This is done as described in (5) above, except that R_o is substituted for R_p . Enter the values of ϵ_o on line 6.

(7) Subtract each value of ϵ_o from the corresponding value of ϵ_p to obtain values of σ_1 . Enter these values on line 7.

(8) Add lines 7 and 8 algebraically to obtain values of σ_L . Enter these values on line 9.

f. If it is desired to calculate the leads with an ordinary slide rule or calculating machine, the form shown below must be changed to show the functions of the angles. By using the Crichlow slide rule the angle is found directly, whereas on an ordinary slide rule or calculating machine the trigonometric function of the angle is found. The angle then will be found by referring to tables of natural trigonometric functions. Leads for coming courses can also be measured graphically.

**CALCULATION OF LEADS FOR ANTI-AIRCRAFT AUTOMATIC WEAPONS
COMING-CONSTANT ALTITUDE COURSE**

[Gun—37-mm; M1A2. $H=500$ yards; $Sg=70$ yards/seconds $FT=37-AA-N-1$; $MV=2,700$ feet/seconds] Calculation Form No. 1

Coming-Constant Altitude	Solution by Crichton slide rule			
	Set L at	Set S at	Turn both until S is at	Read under L on
1. R_p	Assumed or selected			
2. $\epsilon_p = \tan^{-1} \frac{H}{R_p}$	H or R_p (larger) Scale E	H or R_p (smaller) Scale E	Index Scale E	Scale C_1
3. t_p	From firing tables using H and R_p			
4. $S_g t_p$	S_g Scale E	Index Scale E	t_p Scale E	Scale E
5. $R_o = R_p \pm S_g t_p$	+on approaching leg -on receding leg			
6. $\epsilon_o = \tan^{-1} \frac{H}{R_o}$	H or R_o (larger) Scale E	H or R_o (smaller) Scale E	Index Scale E	Scale C_1
7. $\sigma_1 = \epsilon_p - \epsilon_o$	Line 2 minus line 6			
8. ϕ	From firing tables using H and R_p			
9. $\sigma_L = \epsilon_p - \epsilon_o + \phi$	Line 7 plus line 8			

¹ If numerator is less than denominator, the angle is less than 800 mills.

■ 62. COMING-DIVING COURSES.—*a.* Figure 8 represents a pictorial view of the approaching leg for a coming-diving course.

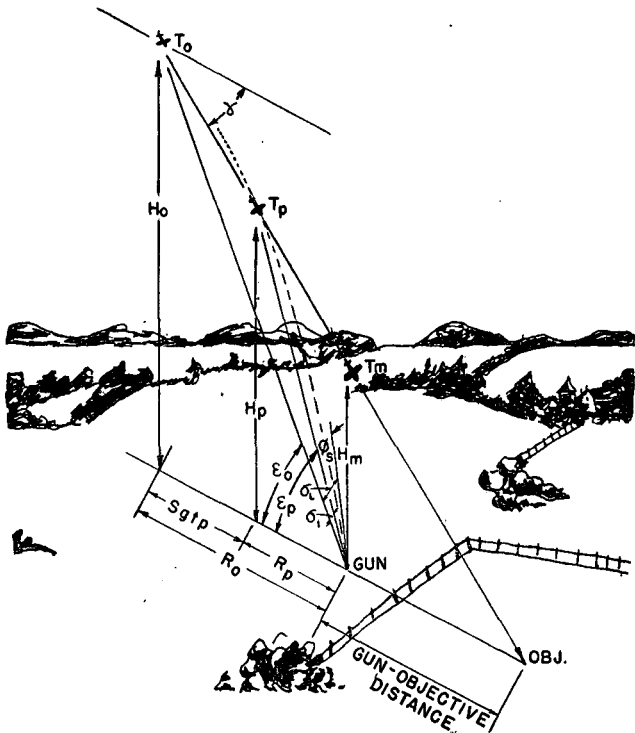

FIGURE 8.—Vertical lead coming-diving course.

As in the coming-constant altitude course, the formula for vertical lead for a coming-diving course is—

$$\sigma L = \epsilon_p - \epsilon_0 + \phi_s$$

b. For courses where the target is diving at a point in rear of the gun position, the value $\epsilon_p - \epsilon_0$ will be positive on the

approaching leg and negative on the receding leg. For courses where the target is diving at a point in front of the gun position, the value $\epsilon_p - \epsilon_o$ will always be negative. For courses where the target is diving directly at the gun position, $\epsilon_p - \epsilon_o = 0$, and $\sigma_L = \phi_s$. As in the case of the coming-constant altitude courses, the superelevation is always positive and is added algebraically to $\epsilon_p - \epsilon_o$.

c. (1) The leads for coming-diving courses can be computed in a manner similar to that for coming-constant altitude courses, but with the addition of one other factor, the angle of dive (γ). H_m and S_g are assumed, as well as γ , and as before, various future positions of the target are selected in terms of R_p . If actual speed of the target (S) is given, ground speed (S_g) may be determined by the formula $S_g = S \cos \gamma$. The computation for each selected future position then consists of determining the following:

H_p from H_m , R_p , and γ .

ϵ_p from R_p and H_p .

R_o from R_p and $S_g t_p$.

H_o from H_m , R_o , and γ .

ϵ_o from R_o and H_o .

σ_L from ϵ_p , ϵ_o , and ϕ_s .

(2) The computations can be rapidly performed by using the M1 (Crichlow) slide rule. Calculation Form No. 2 is a convenient form for use when this slide rule is employed.

d. To calculate the vertical lead:

(1) Enter the selected values of R_p on line 1 of the form.

(2) Determine the values of $R_p \tan \gamma$ for each future position, using the slide rule.

(a) If γ is greater than ($>$) 800 mils, set the long arm (L) to the value of γ on the outer set of figures (tangents) of scale **G**, and the short arm (S) on the index. Without changing the angle of displacement between the two arms, move (L) until (S) is set to the value of R_p on scale **E**, and under (L) read the value of $R_p \tan \gamma$ on scale **E**.

(b) If γ is less than ($<$) 800 mils, set (L) on the index, and (S) to the value of γ on the inner set of figures (cotangents) of scale C. Without changing the angle of displacement between the two arms, set (S) to the value of R_p on scale E, and under (L) read the value of $R_p \tan \gamma$ on scale E. Enter these values on line 2.

(3) Determine the values of H_p for the selected future positions, by adding to (approaching leg) or subtracting from (receding leg) H_m the values of $R_p \tan \gamma$ on line 2. Enter these values on line 3.

(4) Extract from the proper firing tables the times of flight and the superelevations for each selected future position, using H_p and R_p as arguments. Enter the times of flight (nearest hundredth of a second) and the superelevations (nearest mil) on lines 5 and 12, respectively, of the form.

(5) Multiply each time of flight by the assumed ground speed in yards per second, and enter the results (to the nearest yard) on line 6. It may be desired to perform the multiplication of S_g and t_p on the M1 (Crichlow) slide rule. In this case all settings are made and read on scale E. Set the long arm (L) to the assumed S_g in yards per second, and the short arm (S) to the index. Without changing the angle between the arms, shift (L) until (S) is set to the first time of flight, and read under (L) the value of $S_g t_p$. Still without changing the angle between the arms, continue to set (S) to times of flight, and read values of $S_g t_p$ under (L).

(6) Add to (approaching leg) or subtract from (receding leg) the values of R_p (line 1) the values of $S_g t_p$ (line 6) to obtain values of R_o . Enter these values on line 7.

(7) Determine the values of $R_o \tan \gamma$ for each required present position in the same manner that values of $R_p \tan \gamma$ were determined in (2) above, except that R_o is substituted for R_p . Enter the values obtained on line 8.

(8) Determine values of H_o for each required present position by adding to (approaching leg) or subtracting from (receding leg) H_m the values of $R_o \tan \gamma$ on line 8. Enter these values on line 9.

CALCULATION OF LEADS FOR ANTI-AIRCRAFT AUTOMATIC WEAPONS COMING-DIVING COURSE

Calculation Form No. 2.

[Gun—37-mm M1A2. $H_m = 1,100$ yards; $S_f = 70$ yards/seconds; $\gamma = 889$ mils (50°); $FT = 37-AA-N-1$]

Coming-diving course	Solution by Crichtlow slide rule				800	600	400	200	0	200	400	600	800
	Set L at	Set S at	Turn both until S is at	Read under L on									
1. R_p -----	Assumed or selected				800	600	400	200	0	200	400	600	800
2. $R_p \tan \gamma$ -----	$\frac{\gamma \text{ (tan)}}{\text{Scale C}}$ or Index	Index $\frac{\gamma \text{ (cot)}}{\text{Scale C}}$	R_p Scale E	Scale E	954	715	477	238	0	238	477	715	954
3. $H_p = H_m \pm R_p \tan \gamma$ -----	+ on approaching leg - on receding leg				2,054	1,815	1,577	1,338	1,100	862	623	385	146
4. $e_p = \tan^{-1} \frac{H_p}{R_p}$ -----	$\frac{H_p \text{ or } R_p \text{ (larger)}}{\text{Scale E}}$	$\frac{H_p \text{ or } R_p \text{ (smaller)}}{\text{Scale E}}$	Index Scale E	Scale C	1,222	1,275	1,347	1,449	1,600	1,368	1,019	581	184
5. t_p -----	From firing tables using H_p and R_p				3.71	3.02	2.43	1.91	1.48	1.14	0.94	0.90	1.04
6. S_{t_p} -----	Index Scale E	Index Scale E	t_p Scale E	Scale E	260	211	170	134	104	80	66	63	73

7. $R_o = R_p \pm S_t \epsilon_p$	+on approaching leg -on receding leg		1,060	811	570	334	104	120	334	537	727
8. $R_o \tan \gamma$	$\frac{\gamma (\tan)}{\text{Scale C}}$ or Index	Index $\frac{\gamma (\cot)}{\text{Scale C}}$	Scale E		Scale E		Scale E		Scale E		867
			1,264	967	679	398	124	143	398	640	
9. $H_o = H_m \pm R_o \tan \gamma$	+on approaching leg -on receding leg		2,364	2,067	1,779	1,498	1,224	957	702	460	233
10. $\epsilon_o = \tan^{-1} \frac{H_o}{R_o}$	$\frac{H_o \text{ or } R_o \text{ (larger)}}{\text{Scale E}}$	$\frac{H_o \text{ or } R_o \text{ (smaller)}}{\text{Scale E}}$	Scale C		Scale E		Scale E		Scale E		316
			1,171	1,219	1,284	1,377	1,514	1,473	1,148	722	
11. $\sigma_1 = \epsilon_p - \epsilon_o$	Line 4 minus line 10		51	56	63	72	86	-105	-129	-141	-132
12. ϕ_s	From firing tables using H_p and R_p		12	9	7	4	2	4	6	7	9
13. $\sigma_L = \epsilon_p - \epsilon_o + \phi_s$	Line 11 plus line 12		63	65	70	76	88	-101	-123	-134	-122

† If numerator is less than denominator, the angle is less than 800 mils.

(9) Compute the values of ϵ_p for each selected future position, using the slide rule. To do this, set the long arm (L) on the larger value, R_p or H_p , on scale E, and the short arm (S) on the smaller value, R_p or H_p , on scale E. Without changing the angle between the two arms, move (L) and (S) until (S) is on the index of scale E, and read the value of ϵ_p under (L) on scale C. Note that scale C has two sets of readings. If H_p is less than R_p , read the smaller angle. If H_p is greater than R_p , read the larger angle. Enter the values of ϵ_p on line 4.

(10) Compute the values of ϵ_o for each present position corresponding to a selected future position, using the slide rule. This is done as described in (9) above, except that R_o and H_o are substituted for R_p and H_p , respectively. Enter the values of ϵ_o on line 10.

(11) Subtract each value of ϵ_o from the corresponding value of ϵ_p to obtain values of σ_1 (or $\epsilon_p - \epsilon_o$). Enter these values on line 11.

(12) Add lines 11 and 12 algebraically to obtain values of σ_L . Enter these values on line 13.

■ 63. CROSSING-CONSTANT ALTITUDE COURSES.—*a.* When computing leads for a crossing-constant altitude course, both vertical leads and lateral leads must be determined. Figure 9 represents the approaching leg of a crossing-constant altitude course. The formulas for computing the leads for such a course are—

$$\delta_L \text{ (lateral lead)} = \sin^{-1} \frac{Sgt_p \sin \alpha_p}{D_o}$$

$$\sigma_L \text{ (vertical lead)} = \left(\sin^{-1} \frac{Sgt_p \cos \alpha_p \sin \epsilon_p}{D_o \cos \delta_L} \right) + \phi_s.$$

The various steps required to develop these formulas for a point on the approaching leg of the course are shown in figures 9, 10, and 11①. These formulas are also correct for the receding leg of the course.

b. To derive the lateral lead formula:

(1) Referring to figure 9, the right triangle, T_o' -Gun-A, is constructed by extending R_p beyond T_p' . (The location of T_p' is determined by dropping a vertical line from T_p until it

intersects the ground. Likewise, T_o' is located by dropping a vertical line from T_o until it intersects the ground.) Draw a line from T_o' perpendicular to R_p extended. The intersection is marked A . In the right triangle $T_o'-T_p'-A$, the side $T_o'-T_p'$ (which is the hypotenuse of the triangle) is equal to Sgt_p . The angle $T_o'-T_p'-A$ is equal to α_p . Hence the side $T_o'-A$ is equal to $Sgt_p \sin \alpha_p$.

(2) From (1) above, the horizontal triangle $T_o'-A-T_p'$ has been constructed. Referring to figure 10, simply lift this

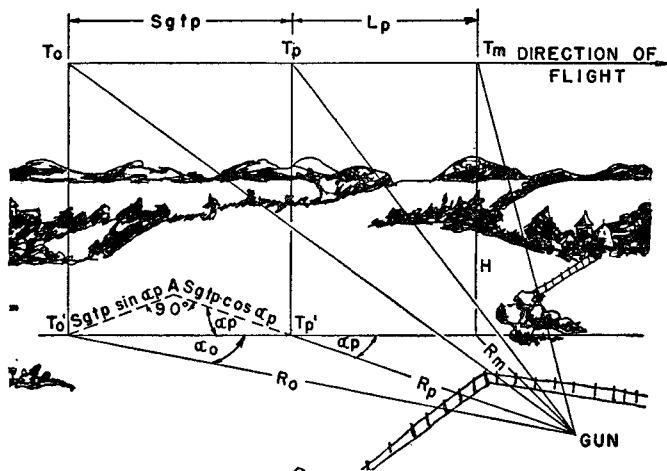

FIGURE 9.—Crossing-constant altitude course.

horizontal triangle vertically, superimposing T_o' on T_o , and T_p' on T_p . The point T_o'' will be vertically above A and at the same altitude as T_o and T_p . The side $T_o'-A$ has already been found equal to $Sgt_p \sin \alpha_p$. Therefore, the side T_o-T_o'' also equals $Sgt_p \sin \alpha_p$. It is also evident from the figure, and true, that the side $T_o''-T_p$ lies in the same vertical plane as the vertical triangle, Gun- T_p-T_p' .

(3) As lateral leads are measured in the slant plane, it is only necessary to calculate the slant plane angle, T_o -Gun- T_o'' , which is the lateral lead (δ_L).

(a) Angle of $T_o'' - T_p - \text{Gun} = 180^\circ - \epsilon_p$.

(b) $\sin (180^\circ - \epsilon_p) = \sin \epsilon_p$ (the sine of the supplementary angle is equal to the sine of the angle itself).

(c) Thus,
$$\frac{\sin \sigma_1}{S_g t_p \cos \alpha_p} = \frac{\sin \epsilon_p}{D_o \cos \delta_L}$$

(d) Therefore
$$\sigma_1 = \sin^{-1} \frac{S_g t_p \cos \alpha_p \sin \epsilon_p}{D_o \cos \delta_L}$$

(5) As in the case of coming courses, $\sigma_L = \sigma_1 + \phi_s$. σ_1 is always positive on the approaching leg and negative on the receding leg. ϕ_s is always positive and is added algebraically to σ_1 .

d. (1) To compute the leads for any one course, the altitude, ground speed of the target, and minimum horizontal range (R_m) of the course are assumed. Various future positions of the target are selected in terms of L_p . For convenience in computation, it will be found advantageous to select values of H , R_m , and L_p in even hundreds of yards and values of S_g in even tens of yards per second. The computation for each selected future position consists of determining t_p , α_p , D_o , ϵ_p and ϕ_s and substituting them in the lead formulas to obtain δ_L and σ_L .

(2) As in the case of coming courses, computations are facilitated by the use of the M1 (Crichlow) slide rule. Calculation Form No. 3 is a convenient form for use when this slide rule is employed.

e. To calculate the lateral lead:

(1) Enter the selected values of L_p on line 1 of the form. The values of L_p should be determined in the same manner as the values for R_p on the coming courses in paragraph 61d(1).

(2) Using the slide rule, determine the values of α_p for the selected future position. For each position, set the long arm (L) to the larger value, R_m or L_p , on scale E, and the short arm (S) on the smaller value, R_m or L_p , on scale E. Without changing the angular displacement, move (L) until (S) is on the index of scale E, and read the value of α_p under (L) on scale C, reading the greater angle if R_m is greater than L_p and the smaller angle if R_m is less than L_p . Enter values α_p on line 2.

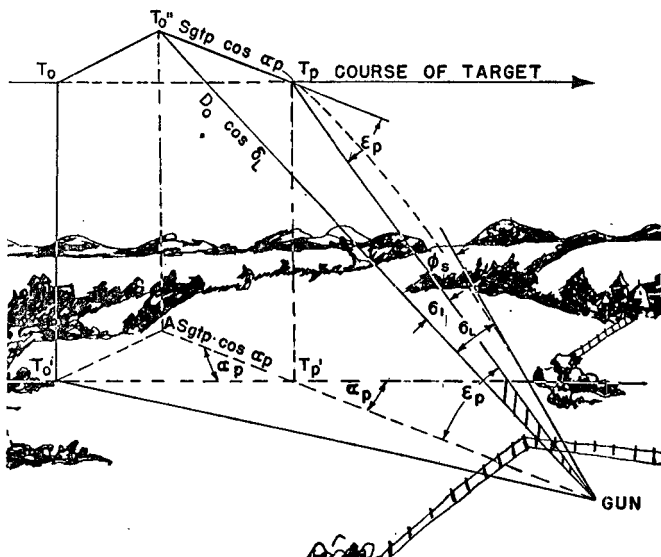

- ① Principal vertical lead angle and superelevation under firing table conditions, crossing-constant altitude course.

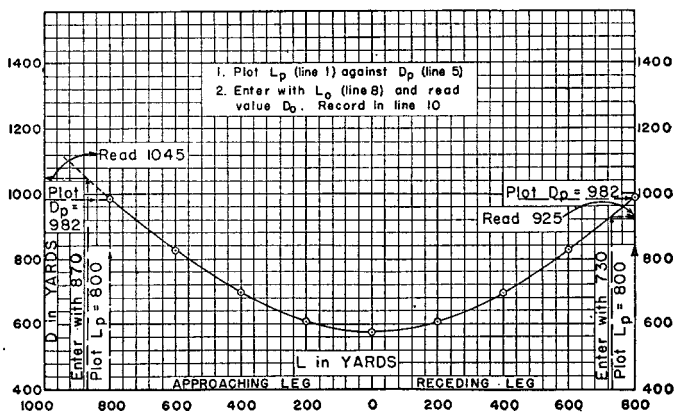

- ② Relationship of L to D .

FIGURE 11.

(3) Using the slide rule, determine the values of R_p for the selected future positions. For each position, set the long arm (L) to R_m on scale E, and the short arm (S) on the index of scale E. Without changing the angular displacement of the arms, move (L) until (S) is on the value of α_p (line 2) on scale D and read the value of R_p under (L) on scale E. Enter values of R_p on line 3.

(4) Using the slide rule, determine the values of ϵ_p for the selected future positions. Proceed as in (2) above, substituting H for R_m and R_p for L_p . Enter values of ϵ_p on line 4.

(5) Using the slide rule, determine the values of D_p for the selected future positions. Proceed as in (3) above, substituting H for R_m and ϵ_p for α_p . Enter values of D_p on line 5.

(6) Enter the firing tables with D_p and ϵ_p (or H and R_p) as arguments, and extract values of t_p and ϕ_s for each selected future position. Enter the values of t_p (nearest hundredth second) and ϕ_s (nearest mil) on lines 6 and 16, respectively.

(7) Multiply each time of flight by the assumed ground speed of the target in yards per second, and enter the results, to the nearest yard, on line 7. It may be desired to perform the multiplication of S_g and t_p on the slide rule. Set the long arm (L) to the assumed S_g in yards per second on scale E, and the short arm (S) on the index. Without changing the angle between the arms, shift (L) until (S) is set to the first time of flight and read under (L) the value of $S_g t_p$. Still without changing the angle between the arms, continue to set (S) to times of flight, and read values of $S_g t_p$ under (L).

(8) Add to (approaching leg) or subtract from (receding leg) the values of L_p (line 1) the value of $S_g t_p$ (line 7) to obtain values of L_o corresponding to each value of L_p . Enter these values on line 8.

(9) Using the slide rule, determine the values of $S_g t_p \sin \alpha_p$ for the selected future positions. For each position, set the long arm (L) to $S_g t_p$ on scale E, and the short arm (S) to the value of α_p (line 2) on scale D. Without changing the angular displacement of the arms, move (L) until (S) is on index of scale E, and read the value of $S_g t_p \sin \alpha_p$ under (L) on scale E. Enter these values on line 9.

CALCULATION OF LEADS FOR ANTIAIRCRAFT AUTOMATIC WEAPONS
CROSSING-CONSTANT ALTITUDE COURSE

[$H=299$ yards; $R_m=485$ yards, $S_e=51.3$ yards/seconds; FT=0.50-AA-E-4] Calculation Form No. 3.

Crossing-constant altitude course	Solution by Crichtow slide rule												
	Set L at	Set S at	Turn both until S is at	Read under L on									
1. L_p -----	Assumed or selected				800	600	400	200	0	200	400	600	800
2. $\alpha_p = \tan^{-1} \frac{R_m}{L_p}$ -----	R_m or L_p (larger) Scale E	R_m or L_p (smaller) Scale E	Index Scale E	Scale C1	555	692	897	1, 202	1, 600	1, 202	897	692	555
3. $R_p = \frac{R_m}{\sin \alpha_p} = \frac{L_p}{\cos \epsilon_p}$ -----	R_m Scale E	Index Scale E	Line 2 Scale D	Scale E	936	772	629	525	485	525	629	772	936
4. $\epsilon_p = \tan^{-1} \frac{H}{R_p}$ -----	H or R_p (larger) Scale E	H or R_p (smaller) Scale E	Index Scale E	Scale C1	315	377	452	527	563	527	452	377	315
5. $D_p = \frac{H}{\sin \epsilon_p} = \frac{D_p}{\cos \epsilon_p}$ -----	H Scale E	Index Scale E	Line 4 Scale D	Scale E	982	825	696	605	570	605	696	825	982
6. t_p -----	From firing tables using H and R_p				1.37	1.11	0.90	0.76	0.71	0.76	0.90	1.11	1.37
7. $S_e t_p$ -----	S_e Scale E	Index Scale E	Line 6 Scale E	Scale E	70	57	46	39	36	39	46	57	70

8. $L_o = L_p \pm S_e t_p$	+ on approaching leg - on receding leg		870	657	446	239	36	161	354	543	730
9. $S_e t_p \sin \alpha_p$	Line 7 Scale E	Line 2 Scale D	Index Scale E	Scale E	36	35	36	36	35	36	36
10. D_o	Plot a curve of D_p against L_p and read D_o from the curve for values of L_o .			1,045	865	725	615	572	670	785	925
11. $\delta_L = \sin^{-1} \frac{S_e t_p \sin \alpha_p}{D_o}$	Line 10 Scale E	Line 9 Scale E	Index Scale E	Scale D	35	42	49	60	62	53	40
12. $S_e t_p \cos \alpha_p$	Line 7 Scale E	Line 2 Scale B	Index Scale E	Scale E	30	44	29	15	0	29	60
13. $S_e t_p \cos \alpha_p \sin \epsilon_p$	Line 12 Scale E	Line 4 Scale D	Index Scale E	Scale E	18	16	12	7	0	12	18
14. $D_o \cos \delta_L$	Line 10 Scale E	Line 11 Scale B	Index Scale E	Scale E	1,044	864	724	614	572	669	924
15. $\sigma_1 = \sin^{-1} \frac{S_e t_p \cos \alpha_p \sin \epsilon_p \epsilon^{+2}}{L_o \cos \delta_L}$	Line 14 Scale E	Line 13 Scale E	Index Scale E	Scale D	18	19	17	12	0	-18	-20
16. ϕ_s	From firing tables using H and R_p			9	7	6	5	5	6	7	9
17. $\sigma_L = \delta_1 + \phi_s$	Line 15 plus line 16			27	26	23	17	5	-7	-14	-11

1 If numerator is less than denominator, the angle is less than 900 mils.
 2 σ_1 is + on approaching leg and - on receding leg.

(10) Determine graphically the value of D_o for each value of D_p in the following manner. Plot on cross-section paper, as shown in figure 11②, to any convenient scale, values of D_p (line 5) as ordinates against the corresponding values of L_p (line 1) as abscissas. With a French curve, draw a smooth curve through the plotted points. Then from this curve, substituting D_o for D_p and L_o for L_p , read the values of D_o corresponding to values of L_o shown on line 8. Enter these values on line 10.

NOTE.—The relationship of L to D is the same for a given point on the course regardless of whether the point represents T_o or T_p .

(11) Using the slide rule, determine δ_L for each future position. For each position, set the long arm (L) on the value of D_o on scale E, and the short arm (S) on the value of $Sgt_p \sin \alpha_p$ on scale E (line 9). Without changing the angular displacement of the arms, move (L) until (S) is on the index of scale E, and read under (L) the value of δ_L on scale D. (See appendix III for procedure on reading mil angle values on the D scale of the Crichlow slide rule.) Enter these values on line 11. They are the required lateral leads.

f. To calculate the vertical lead:

(1) Using the slide rule, determine the value of $Sgt_p \cos \alpha_p$ for each future position. For each position, set the long arm (L) to the value of Sgt_p on scale E and the short arm (S) on the value of α_p (line 2) on scale B. Without changing the angular displacement between the arms, move (L) until (S) is on the index of scale E, and read $Sgt_p \cos \alpha_p$ under (L) on scale E. Enter values of $Sgt_p \cos \alpha_p$ on line 12.

(2) Using the slide rule, determine values of $Sgt_p \cos \alpha_p \sin \epsilon_p$ for the required future positions. Proceed as in e(9) above, substituting $Sgt_p \cos \alpha_p$ for Sgt_p , and ϵ_p for α_p . Enter values of $Sgt_p \cos \alpha_p \sin \epsilon_p$ on line 13.

(3) Using the slide rule, determine values of $D_o \cos \delta_L$ for the required future positions. Proceed as in (1) above, substituting D_o for Sgt_p , and δ_L for α_p . Enter values of $D_o \cos \delta_L$ on line 14.

(4) Using the slide rule, determine values of σ_1 for the required future positions. Proceed as in e(11) above, sub-

stituting $D_o \cos \delta_L$ for D_o , and $Sgt_p \cos \alpha_p \sin \epsilon_p$ for $Sgt_p \sin \alpha_p$. Enter values of σ_1 on line 15. σ_1 is plus on the approaching leg and minus on the receding leg.

(5) Add values of σ_1 (line 15) and ϕ_s (line 16) algebraically to obtain values of σ_L . Enter these values on line 17. They are the required vertical leads.

■ 64. CROSSING-DIVING COURSES.—*a.* As in the case of crossing-constant altitude courses, both lateral and vertical leads

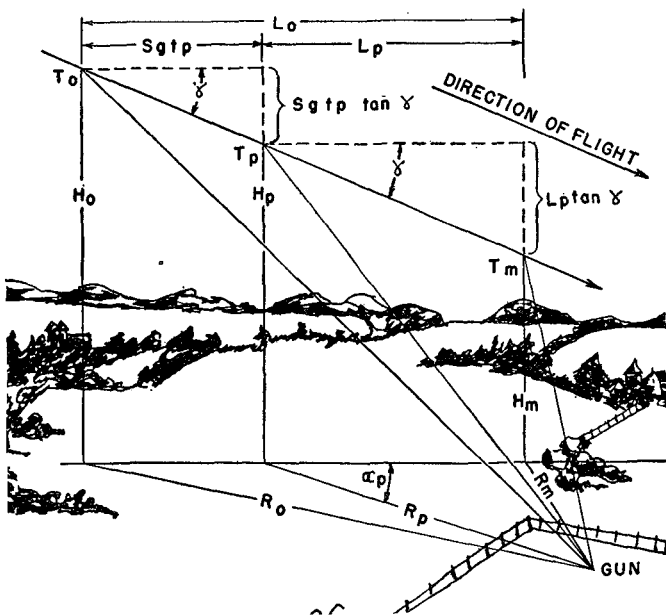

FIGURE 12.—Crossing-diving course.

must be computed for crossing-diving courses. The computation is similar to that for crossing-constant altitude courses. One additional factor, angle of dive, must be considered and H_m assumed instead of H .

b. Figure 13 represents the approaching leg of a crossing-diving course. The formulas for computing the leads for such a course are—

$$\delta_L \text{ (lateral lead)} = \sin^{-1} \frac{Sgt_p \sin \alpha_p}{D_o}$$

$$\sigma_L \text{ (vertical lead)} = \left(\sin^{-1} \frac{Sgt_p \tan \gamma \sin (\epsilon_p \mp \gamma \alpha)}{\sin \gamma_v D_o \cos \sigma_L} \right) + \phi_s$$

c. To determine the lateral lead:

(1) The formula for lateral lead for a crossing-diving course is identical with, and developed in the same manner as, the formula for lateral lead for a crossing-constant altitude course.

(2) The various steps required to develop the vertical lead formula for a point on the approaching leg of the course are shown in figures 13 to 17, inclusive. These formulas are also correct for the receding leg of the course.

d. To derive the vertical lead formula:

(1) Referring to figures 13, 14, and 15, the difference in altitude between T_o and T_p is $Sgt_p \tan \gamma$, which is equal to the line T_o-C .

(2) By actual construction the side $T_o''-B$ is made equal to the side T_o-C .

(3) Therefore, the side $T_o''-B = Sgt_p \tan \gamma$.

(4) By construction the side $B-T_p =$ the side $A-T_p'$.

(5) The side $A-T_p'$ is equal to $Sgt_p \cos \alpha_p$.

(6) Therefore the side $B-T_p = Sgt_p \cos \alpha_p$.

(7) Referring to figure 13, simply connect the two points T_o'' and T_p with a line. This line then becomes the projection of the target's course on to the vertical plane through the gun and T_p . The angle formed, $T_o''-T_p-B$, is the projection of the angle of dive (γ) on to this vertical plane. This new angle, $T_o''-T_p-B$, is called γ_v , and is always greater than γ because, as both of these latter angles subtend the same vertical distance, the side $T_o''-T_p$ is shorter than the side T_o-T_p .

(8) In the right triangle $T_o''-T_p-B$,

$$\gamma_v = \tan^{-1} \frac{T_o''-B}{T_p-B}$$

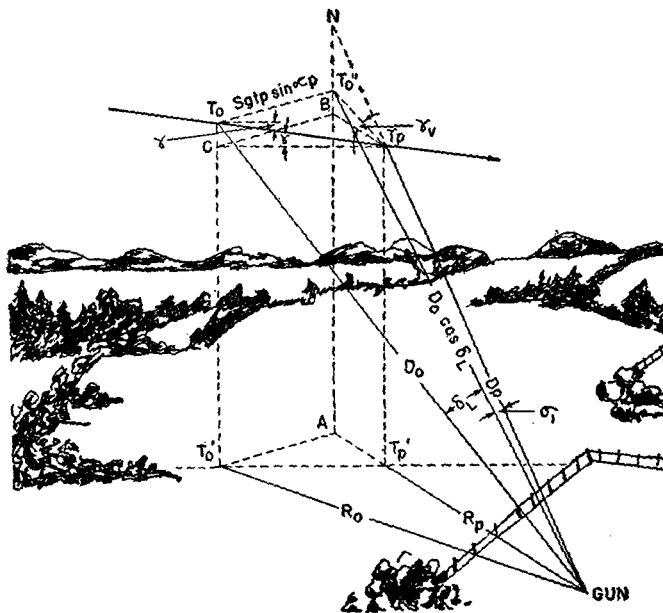
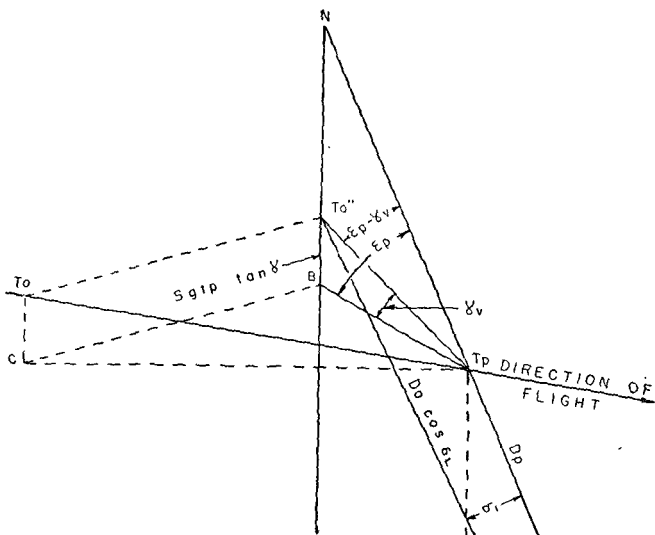

FIGURE 13.—Crossing-diving course, approaching leg.

(9) Substituting, $\gamma_v = \tan^{-1} \frac{Sgt_p \tan \gamma}{Sgt_p \cos \alpha_p}$

(10) In the same triangle, the $\sin \gamma_v = \frac{\text{side } T_o''-B}{\text{side } T_p-T_o''} = \frac{Sgt_p \tan \gamma}{\text{side } T_p-T_o''}$

(11) The side $T_p-T_o'' = \frac{Sgt_p \tan \gamma}{\sin \gamma_v}$

 FIGURE 15.—Determination of σ_1 , cross-diving course.

- (17) The angle $N-T_p-B = \epsilon_p$.
- (18) The angle $T_o''-T_p-B = \gamma_v$.
- (19) Thus, angle $N-T_p-T_o'' = \epsilon_p - \gamma_v$.
- (20) Therefore, angle $T_o''-T_p-Gun = 180^\circ - (\epsilon_p - \gamma_v)$.
- (21) $\sin 180^\circ - (\epsilon_p - \gamma_v) = \sin (\epsilon_p - \gamma_v)$.
- (22) Therefore,
$$\frac{\sin \sigma_1}{S_g t_p \tan \gamma} = \frac{\sin (\epsilon_p - \gamma_v)}{D_o \cos \delta_L}$$
- (23)
$$\sigma_1 = \sin^{-1} \frac{\sin \gamma_v}{\sin \gamma_v} \frac{S_g t_p \tan \gamma \sin (\epsilon_p - \gamma_v)}{D_o \cos \delta_L}$$

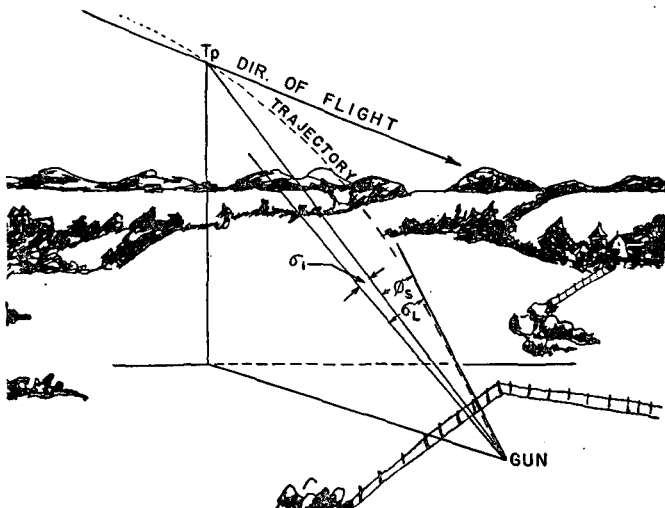

FIGURE 17.—Determination of σ_L , approaching leg.

e. (1) To compute the leads for any one course, the altitude to the midpoint of the course, the ground speed of the target, the minimum horizontal range, and the angle of dive are assumed. If actual speed of the target is assumed, S_g is obtained by the formula $S_g = S \cos \gamma$. Various future positions of the target are selected in terms of L_p . For convenience in computation, it will be found advantageous to select values of H_m , R_m , and L_p in even hundreds of yards and values of S_g (or S) in even tens of yards per second. The computation for each selected future position consists of determining t_p , α_p , D_o , ϵ_p , γ_v , and ϕ_s and substituting them in the lead formulas to obtain δ_L and σ_L .

(2) As in the case of other types of courses, computations are facilitated by the use of the M1 (Crichlow) slide rule. Calculation Form No. 4 is a convenient form for use when this slide rule is employed.

f. To calculate the lateral lead:

(1) Enter the selected values of L_p on line 1 of the form.

(2) Using the slide rule, determine the values of a_p for the selected future positions. For each position, set the long arm (L) to the larger value, R_m or L_p , on scale E, and the short arm (S) on the smaller value, R_m or L_p , on scale E. Without

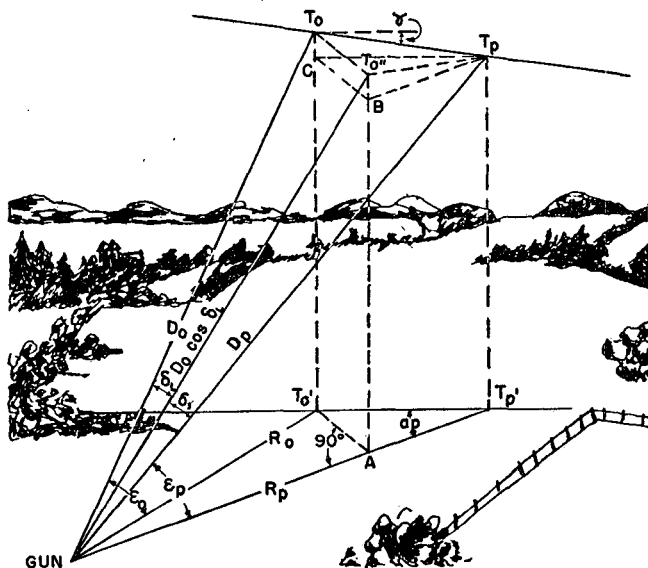

FIGURE 18.—Crossing-diving course, receding leg.

changing the angular displacement, move (L) until (S) is on the index of scale E, and read the value of a_p under (L) on scale C. Read the greater angle if R_m is greater than L_p , and the smaller angle if R_m is less than L_p . Enter values of a_p on line 2.

(3) Using the slide rule, determine the values of R_p for the selected future positions. For each position, set the long arm (L) to the value of R_m on scale E, and the short arm (S) to the index of scale E. Without changing the an-

selected future position. Enter these values of H_p on line 5.

(6) Using the slide rule, determine the values of e_p for the selected future positions. Proceed as in (2) above, substituting H_p for R_m , and R_p for L_p . Enter values of e_p on line 6.

(7) Using the slide rule, determine the values of D_p for the selected future positions. Proceed as in (3) above, substituting H_p for R_m , and e_p for α_p . Enter values of D_p on line 7.

(8) Enter the firing tables with D_p and e_p (or H_p and R_p) as arguments, and extract values of t_p and ϕ_s for each selected future position. Enter the values of t_p (nearest hundredth second) and ϕ_s (nearest mil) on lines 8 and 22, respectively.

(9) Multiply each time of flight by the assumed ground speed in yards per second, and enter the results, to the nearest yard, on line 9. It may be desired to perform the multiplication of S_g and t_p on the slide rule. In this case all settings are made and read on scale E. Set the long arm (L) to the assumed S_g in yards per second on scale E, and the short arm (S) on the index of scale E. Without changing the angle between the arms, shift (L) until (S) is set to the first time of flight and read under (L) the value of $S_g t_p$. Still without changing the angle between the arms, continue to set (S) to times of flight, and read values of $S_g t_p$ under (L) on scale E.

(10) Add to (approaching leg) or subtract from (receding leg) the values of L_p (line 1) the values of $S_g t_p$ (line 9) to obtain values of L_o corresponding to each value of L_p . Enter these values on line 10.

(11) Using the slide rule, determine values of $S_g t_p \sin \alpha_p$ for the selected future positions. For each position, set the long arm (L) to $S_g t_p$ on scale E, and the short arm (S) to the value of α_p on scale D. Without changing the angular displacement of the arms, move (L) until (S) is set to the index, scale E, and under (L) read the value of $S_g t_p \sin \alpha_p$ on scale E. Enter these values on line 11.

(12) Determine graphically the value of D_o for each value of D_p in the following manner. Plot on cross-section paper, to any convenient scale, values of D_p (line 7) as ordinates against the corresponding values of L_p (line 1) as abscissas.

With a French curve, draw a smooth curve through the plotted points. Then from this curve, substituting D_o for D_p , and L_o for L_p , read for values of L_o (line 10) the corresponding values of D_o . Enter these values on line 12.

(13) Using the slide rule, determine δ_L for each future position. For each position, set the long arm (L) on the value of D_o on scale E, and the short arm (S) on the value of $Sgt_p \sin \alpha_p$ on scale E. Without changing the angular displacement of the arms, move (L) until (S) is on the index of scale E, and read under (L) the value of δ_L on scale D. Enter these values on line 13. They are the required lateral leads. (See appendix III for notes on use of the Crichlow slide rule.)

g. To calculate the vertical lead:

(1) Using the slide rule, determine the values of $Sgt_p \tan \gamma$ for the selected future positions. Proceed as in b(4) above, substituting Sgt_p for L_p . Enter values of $Sgt_p \tan \gamma$ on line 14.

(2) Using the slide rule, determine the value of $Sgt_p \cos \alpha_p$ for each future position. For each position, set the long arm (L) to the value of Sgt_p on scale E, and the short arm (S) to the value of α_p on scale B. Without changing the angular displacement between the arms, move (L) until (S) is set on the index of scale E, and read $Sgt_p \cos \alpha_p$ under (L) on scale E. Enter values of $Sgt_p \cos \alpha_p$ on line 15.

(3) Using the slide rule, determine the values of γ_v for the selected future positions. Proceed as in b(2) above, substituting $Sgt_p \tan \gamma$ for R_m , and $Sgt_p \cos \alpha_p$ for L_p . Enter values of γ_v on line 16.

(4) Add to (receding leg) or subtract from (approaching leg) the values of ϵ_p the corresponding values of γ_v to obtain values of $(\epsilon_p \mp \gamma_v)$. Enter these values on line 17 without sign.

(5) Using the slide rule, determine the values of $Sgt_p \tan \gamma \sin (\epsilon_p \mp \gamma_v)$ for the selected future positions. Proceed as in b(11) above, substituting $Sgt_p \tan \gamma$ for Sgt_p , and $(\epsilon_p \pm \gamma_v)$ for α_p . Enter the values of $Sgt_p \tan \gamma \sin (\epsilon_p \pm \gamma_v)$ on line 18. (See appendix III.)

(6) Using the slide rule, determine the values of $D_o \cos \delta_L$ for the selected future positions. Proceed as in (2) above,

substituting D_o for Sgt_p , and δ_L for α_p . Enter the values of $D_o \cos \delta_L$ on line 19.

(7) Using the slide rule, determine the values of $D_o \cos \delta_L \sin \gamma_v$ for the selected future positions. Proceed as in b(11) above, substituting $D_o \cos \delta_L$ for Sgt_p , and γ_v for α_p . Enter the values of $D_o \cos \delta_L \sin \gamma_v$ on line 20.

(8) Using the slide rule, determine the values of σ_1 for the required future positions. Proceed as in b(13) above, substituting $D_o \cos \delta_L \sin \gamma_v$ for D_o , and $Sgt_p \tan \gamma \sin (\epsilon_p \pm \gamma_v)$ for $Sgt_p \sin \alpha_p$. Enter values of σ_1 on line 21. Note that the value of σ_1 is positive if ϵ_p is greater than γ_v , and negative if ϵ_p is less than γ_v on approaching leg, and is also negative on the receding leg. (See appendix III.)

(9) Determine values of σ_L for each future position by adding σ_1 and ϕ_s algebraically. Enter values of σ_L on line 23.

h. If it is desired to calculate the leads with an ordinary slide rule or calculating machine, the calculation form must be changed to show the functions of the various angles computed. The angle then can be found by referring to tables of natural trigonometric functions.

Calculation Form No. 4.

CALCULATION OF LEADS FOR AUTOMATIC WEAPONS CROSSING-DIVING COURSE

[$H_m = 1,000$ yards; $R_m = 1,100$ yards; $S_g = 50$ yards/seconds; $\gamma = 889$ mils; FT = 37-AA-N-1]

		Solution by Crichtlow slide rule											
		Set L at	Set S at	Turn both until S is at	Read under L on								
		Assumed or selected											
		R_m or L_p (larger) Scale E	R_m or L_p (smaller) Scale E	Index Scale E	Scale C ¹								
		R_m Scale E	Index Scale E	Line 2 Scale D	Scale E								
		γ (tan) Scale C	Index	L_p Scale E	Scale E								
		Index	γ (cot) Scale C	+ on approaching leg - on receding leg									
		H_p or R_p (larger) Scale E	H_p or R_p (smaller) Scale E	Index Scale E	Scale C ¹								
		H_p Scale E	Index Scale E	Line 6 Scale D	Scale E								
1.	L_p -----				800	600	400	200	0	200	400	600	800
2.	$\alpha_p = \tan^{-1} \frac{R_m}{L_p}$ -----				960	1,091	1,245	1,417	1,600	1,417	1,245	1,091	960
3.	$R_p = \frac{R_m \cos \alpha_p}{\sin \alpha_p}$ -----				1,360	1,253	1,170	1,119	1,100	1,119	1,170	1,253	1,360
4.	$L_p \tan \gamma$ -----				954	715	477	238	0	238	477	715	954
5.	$H_p = H_m \pm L_p \tan \gamma$ ---				1,954	1,715	1,477	1,238	1,000	762	523	285	46
6.	$\epsilon_p = \tan^{-1} \frac{H_p}{R_p}$ -----				981	957	918	851	752	609	428	228	34
7.	$D_p = \frac{H_p}{\sin \epsilon_p} \cos \epsilon_p$ -----				2,380	2,124	1,884	1,669	1,486	1,354	1,282	1,284	1,376

See footnotes at end of table.

CALCULATION OF LEADS FOR AUTOMATIC WEAPONS CROSSING-DIVING COURSE—Continued

		Solution by Crichton slide rule												
		Set L at	Set S at	Turn both until S is at	Read under L on									
8.	t_p	Firing tables with H_p' and E_p or D_p and E_p'				4.16	3.52	2.96	2.51	2.15	1.91	1.78	1.78	1.95
9.	$S_e t_p$	S_e Scale E	Index Scale E	Line 8 Scale E	Scale E	208	176	148	126	108	96	89	89	98
10.	$L_o = L_p \pm S_e t_p$	+ on approaching leg - on receding leg				1,008	776	548	326	108	104	311	511	702
11.	$S_e t_p \sin \alpha_p$	Line 9 Scale E	Line 2 Scale D	Index Scale E	Scale E	168	154	139	124	108	94	83	78	79
12.	D_o	Plot a curve of D_p against L_p and read D_o from the curve for values of L_o .				2,650	2,350	2,065	1,800	1,580	1,415	1,310	1,280	1,315
13.	$\delta_L = \sin^{-1} \frac{S_e t_p \sin \alpha_p}{D_o}$	Line 12 Scale E	Line 11 Scale E	Index Scale E	Scale D	65	67	69	70	70	68	65	62	61
14.	$S_e t_p \tan \gamma$	γ (tan) Scale C	Index	$S_e t_p$ Scale E	Scale E	248	210	176	150	129	114	106	106	117
		Index	γ (cot) Scale C											

15. $S_e^2 \cos \alpha_p$	Line 9 Scale E	Line 2 Scale B	Index Scale E	Scale E	122	84	51	33	0	17	30	43	58
16. $\gamma_e = \tan^{-1} \frac{S_e^2 \tan \gamma}{S_e^2 \cos \alpha_p}$	Line 14 or 15 (larger) Scale E	Line 14 or 15 (smaller) Scale E	Index Scale E	Scale C ¹	1, 134	1, 212	1, 313	1, 379	1, 600	1, 449	1, 319	1, 207	1, 131
17. $\epsilon_p \mp \gamma_e$	- on approaching leg + on receding leg				153	255	395	528	848	2, 058	1, 747	1, 435	1, 165
18. $S_e^2 \tan \gamma \sin (\epsilon_p \mp \gamma_e)$	Line 14 Scale E	Line 17 Scale D	Index Scale E	Scale E	37	52	67	74	95	103	105	105	106
19. $D_e \cos \delta_L$	Line 12 Scale E	Line 13 Scale B	Index Scale E	Scale E	2, 644	2, 344	2, 060	1, 795	1, 576	1, 411	1, 308	1, 278	1, 312
20. $D_e \cos \delta_L \sin \gamma_e$	Line 19 Scale E	Line 16 Scale D	Index Scale E	Scale E	2, 372	2, 175	2, 041	1, 753	1, 576	1, 396	1, 259	1, 184	1, 175
21. $\sigma_1 = \sin^{-1} \frac{S_e^2 \tan \gamma \sin (\epsilon_p \mp \gamma_e)^2}{D_e \cos \delta_L \sin \gamma_e}$	Line 20 Scale E	Line 18 Scale E	Index Scale E	Scale D	--16	--24	--33	--43	--62	--75	--85	--90	--92
22. ϕ_s	Firing tables with H_p and R_p and D_p or D_p and F_p				20	17	15	14	13	13	13	13	15
23. $\sigma_L = \sigma_1 + \phi_s$	Line 21 plus line 22				4	-7	-18	-29	-49	-62	-72	-77	-77

¹ If numerator is less than denominator, the angle is less than 800 mils.

² On approaching leg σ_1 is positive when ϵ_p is greater than γ_e and negative when ϵ_p is less than γ_e . σ_1 is always negative on receding leg.

CHAPTER 4

LEAD CURVES AND CHARTS

	Paragraphs
SECTION I. Lead curves and lead charts for constant altitude courses.....	65-67
II. Lead charts for dive targets.....	68-72

SECTION I

LEAD CURVES AND LEAD CHARTS FOR CONSTANT ALTITUDE COURSES

■ 65. GENERAL.—*a.* Chapter 3 described the methods of calculating the leads for future positions of the target on various types of courses. To put the leads in a satisfactory form for practical use, they must first be referred to the corresponding present positions by constructing lead curves, and then the data from a number of curves transferred to suitable charts. These curves and charts can be used to familiarize personnel with the initial leads and the rates of change of leads required for particular courses and can also be employed to study the effect of variations in altitude, speed of the target, and other basic elements of data on those same leads and rates of change of leads.

b. The greatest value of lead curves and charts is for use in the training of personnel of those antiaircraft automatic weapons units which control fire with central control equipment. However, they also are valuable when used in training personnel who normally fire with director control in the use of emergency fire control methods, or for training personnel who fire by individual tracer control.

c. Neither lead curves nor lead charts are suitable for use during service firing to obtain the required leads, although they may be used to a limited extent during the early stages of individual firing and preliminary platoon firing if desired. Their main purpose is to familiarize the adjusters, prior to actual firing, with the initial leads and the rates of change of leads which will be required at various points along repre-

sentative courses. However, adjusters should not be permitted to continue to refer to these charts in determining required leads.

■ 66. LEAD CURVES.—*a.* (1) In the computations of leads, the present position corresponding to each selected future position is determined in terms of either L_o (for crossing courses) or R_o (for coming courses). When constructing lead curves, points are plotted in terms of these present position values, L_o or R_o as abscissas and the corresponding lateral or vertical leads as ordinates.

(2) The values of L_o and R_o are computed from the midpoint of the course. Therefore, the midpoint of the course is represented by the y-axis. For crossing courses this y-axis is placed at the center of the plot, and values of L_o are measured left or right from this line. Negative values are measured to the left if the approaching leg of the course is to the left of the midpoint and to the right if the approaching leg is to the right of the midpoint. Positive values are laid off in the opposite direction from negative values. As only the approaching leg of a coming course is usually plotted, the y-axis of the lead curve for this type of course is usually placed at the edge of the plot. Values of R_o are measured from this line.

(3) When all the points for a particular curve have been plotted, the plotted points are connected by a curved line. This curved line is the lead curve (lateral or vertical) for the particular weapon, ammunition, and target course under consideration.

b. If desired, two or more lead curves may be placed on the same plot. These curves may be the lateral and the vertical lead curves for a particular course. Figure 20 is an example of such a plot for a type crossing-constant altitude course when firing a caliber .50 machine gun. Similarly, a series of curves may be plotted for various target courses and speeds, or for the various antiaircraft automatic weapons (see fig. 21). Such grouping of curves facilitates study of the manner in which the leads vary when the basic elements of data or the weapons or ammunition are changed.

c. For a discussion of lead curves see chapter 5.

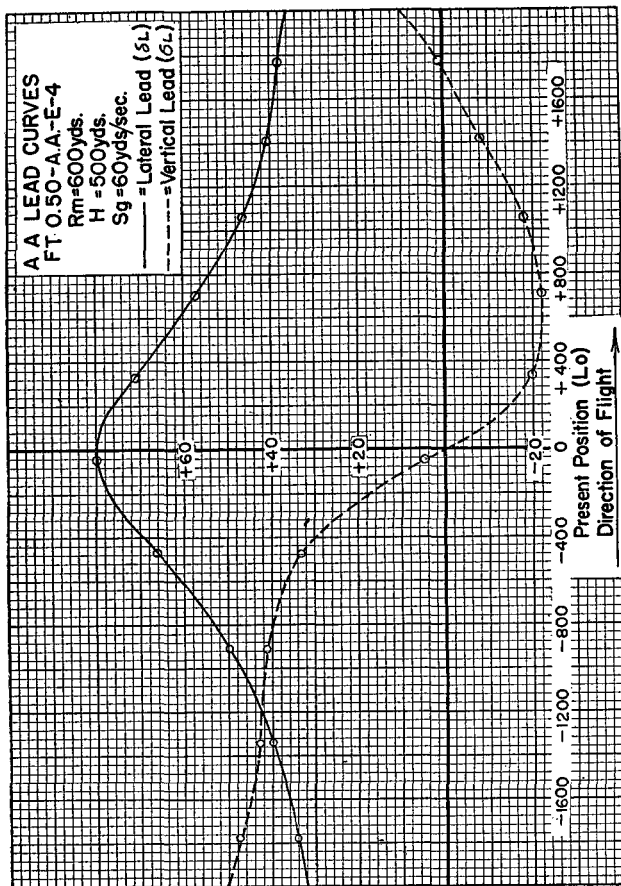

FIGURE 20.—Lateral and vertical lead curves for typical crossing-constant altitude course.

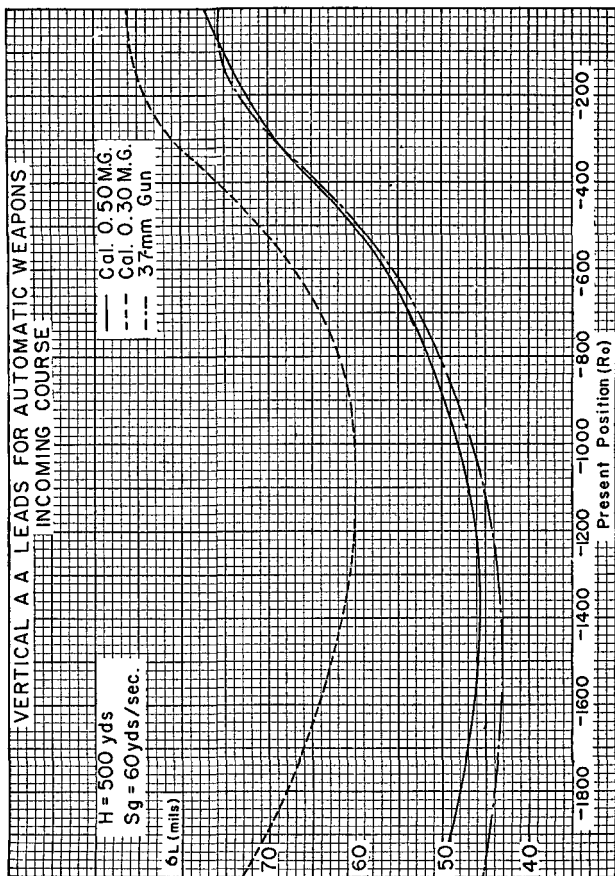

FIGURE 21.—Vertical lead curves for typical coming-constant altitude course (caliber .30 and caliber .50 machine guns and 37-mm gun).

■ 67. LEAD CHARTS.—*a.* Lead charts are constructed from a series of related lead curves. Two types of lead charts have proved particularly satisfactory, one for constant altitude courses and the other for diving courses.

b. (1) The simplest and most practical form of lead chart yet devised is that for crossing-constant altitude courses, examples of which are illustrated in figures 22 and 23. One chart is required for lateral leads and another for vertical leads. Similar charts can be made for constant-altitude coming courses.

(2) A chart for crossing-constant altitude courses is usually prepared from a number of lateral (or vertical) lead curves for the same weapon and the same altitude of course. If desired, two target speeds can be represented. Several courses can be shown, each having a different R_m . The entire chart is constructed to scale to assist personnel in visualizing the courses represented. The method of construction is as follows:

(*a.*) Draw a vertical line through the center of the chart to represent the line of midpoints of all courses. On this line and near the bottom of the chart mark a point representing the gun position. Through this point draw a horizontal line across the chart. Mark off this line to the same scale as the L_o scale of the lead curves, using 100-yard divisions. Mark off to scale, from the gun position, along the line of midpoints, distances equal to the R_m s of the courses to be represented. Through each of these points draw a horizontal line across the chart.

(*b.*) Select a lead curve for the proper weapon, altitude, and speed of target, and place it with the x-axis along the line on the chart representing a course of that R_m and with its y-axis at the line of midpoints. Project the lead values in mils from the lead curve to the line on the lead chart. This is done by marking on the lead curve the points of intersection of the curve with horizontal lines from the scale of ordinates and then dropping a vertical line to the line on the chart from each of these points, and marking the point where these vertical lines strike the horizontal line of the lead chart. Each of these points must be clearly marked by drawing a short vertical line above (or below) the horizontal

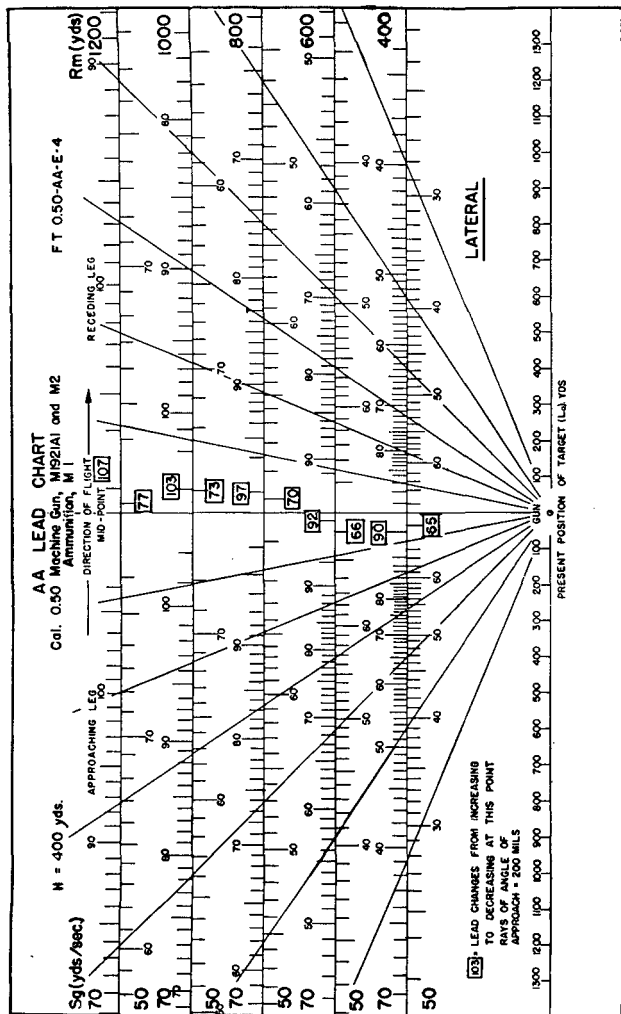

FIGURE 22.—Typical lateral lead chart for crossing-constant altitude courses.

line at that point. The distances between lines should represent 1-mil differences except where they would be too close to be identified, in which case 5-mil divisions are permissible. Every fifth mil line (see fig. 22) is a little longer than the others and every tenth mil line (see fig. 23) is labeled with its value. Any point where the lead changes from increasing to decreasing, or the reverse, should be clearly marked by labeling the mil line with the value, around which is drawn a rectangle (see fig. 22) or other distinguishing mark.

(c) A second lead curve for the same weapon, altitude, and R_m of course but for a different speed of target can be plotted on the same line of the chart by marking the mil divisions below (or above) the line.

(d) In a similar manner all of the selected lead curves can be transferred to the lead chart.

(e) If lines radiating from the point representing the gun position are drawn across the chart at 200-mil intervals, they will be found to assist greatly in orienting the chart when it is desired to use it during the early stages of firing. These lines indicate angles of approach.

(3) Lead charts for coming-constant altitude courses are constructed in a similar manner. However, since no R_m s are involved, one chart can represent as many altitudes as may be plotted on the chart. As in the case of the corresponding lead curves, the line of midpoints is at the edge of the chart. Also, instead of drawing angles of approach, angles of elevation are drawn at 200-mil intervals on the chart.

SECTION II

LEAD CHARTS FOR DIVE TARGETS

■ 68. GENERAL.—*a.* These charts are practical for training use against dive targets because a dive target must of necessity fly a rectilinear course at more or less constant speed. Three elements of data affect the leads. These are angle of dive, gun-objective distance, and ground speed.

b. The effect of angle of dive (γ) on vertical lead is small even for large differences in the angle of dive. The rates

of change for lateral leads are not excessive and can be estimated.

c. The variable gun-objective distance can be readily eliminated by selection of a suitable chart as soon as the gun-objective distance is known.

d. Ground speed has little effect on rate of change of leads. It has an effect on initial leads which is uniform, and which can be readily estimated. (For lead charts see figs. 24 through 31.)

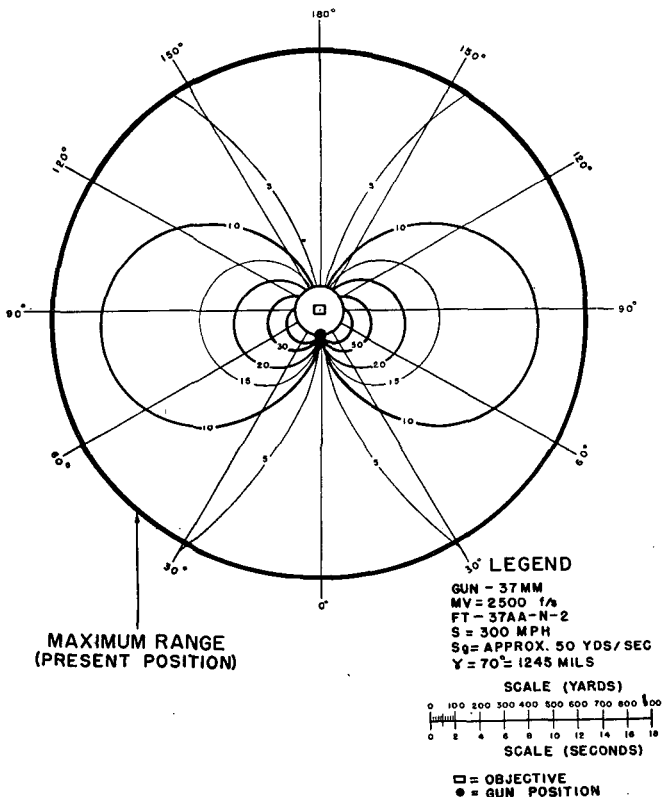

FIGURE 24.—Lateral lead chart, gun-objective distance 100 yards.

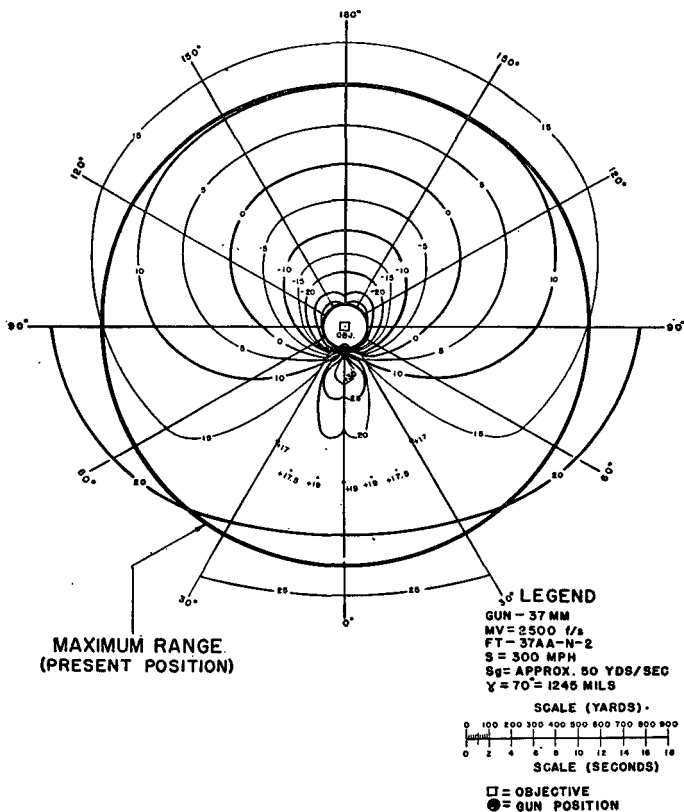

FIGURE 25.—Vertical lead chart, gun-objective distance 100 yards.

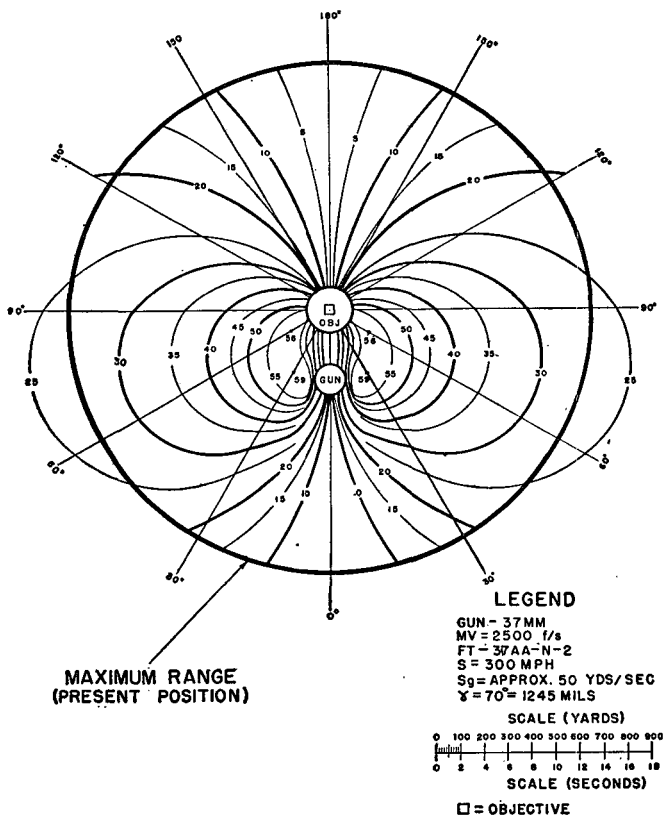

FIGURE 26.—Lateral lead chart, gun-objective distance 300 yards.

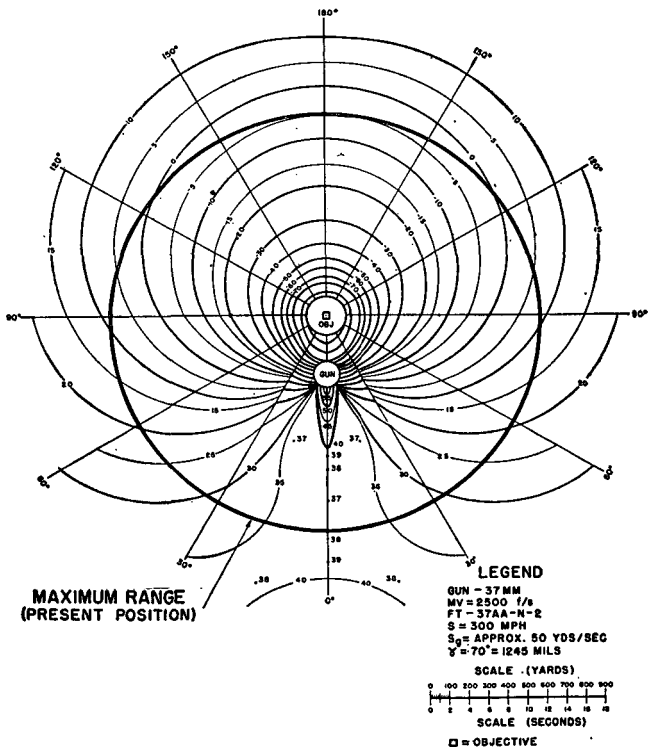

FIGURE 27.—Vertical lead chart, gun-objective distance 300 yards.

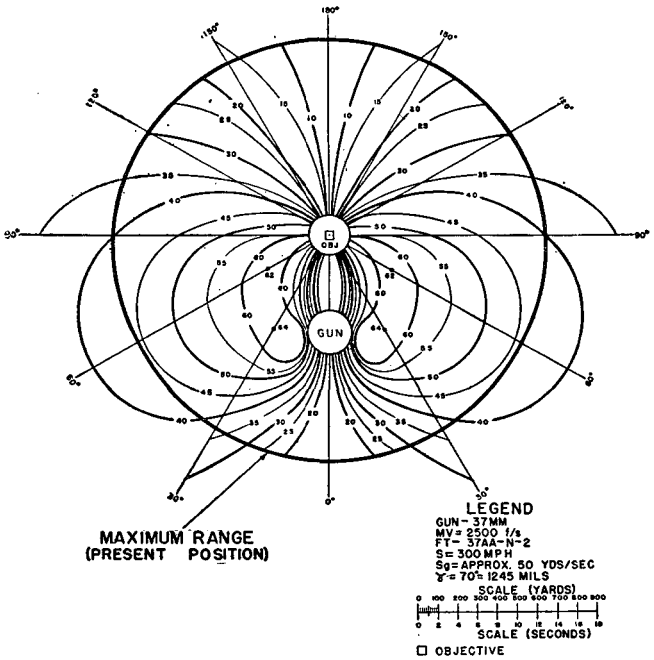

FIGURE 28.—Lateral lead chart, gun-objective distance 500 yards.

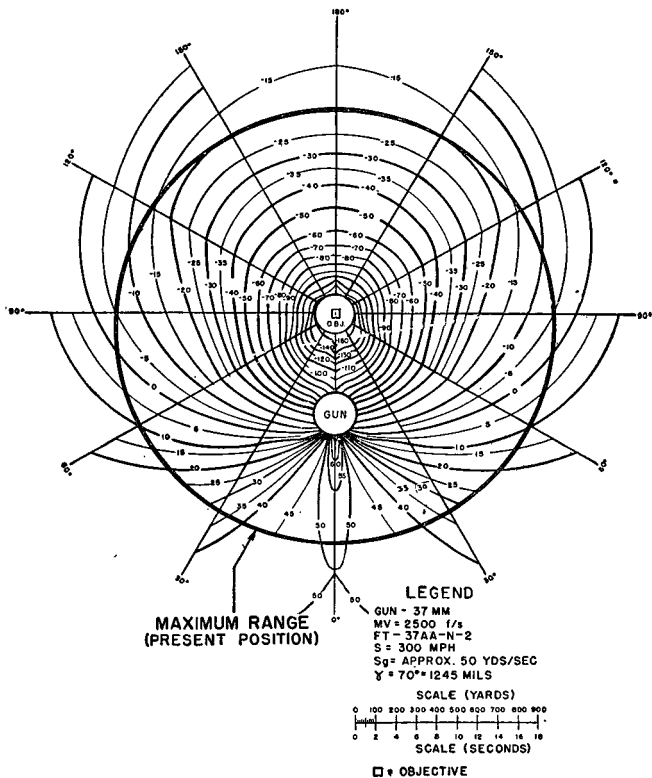

FIGURE 29.—Vertical lead chart, gun-objective distance 500 yards.

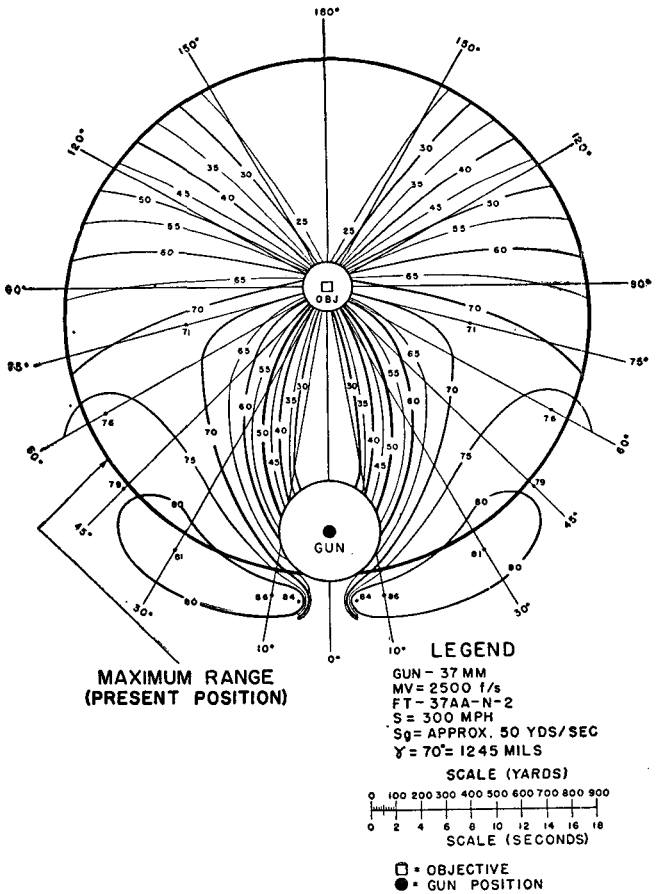

FIGURE 30.—Lateral lead chart, gun-objective distance 1,000 yards.

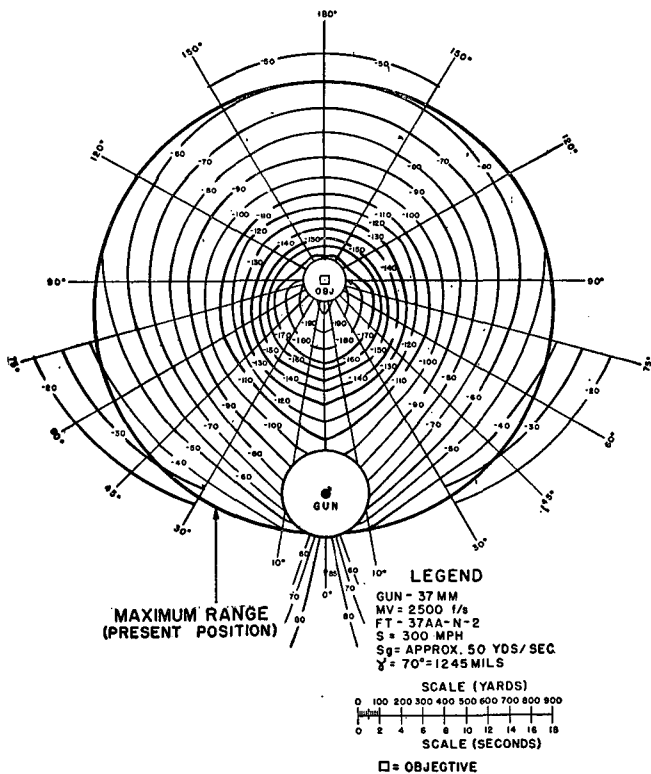

FIGURE 31.—Vertical lead chart, gun-Objective distance 1,000 yards.

■ 69. USE OF LEAD CHARTS.—A set of lead charts (vertical and lateral) for dive targets should be available to every fire unit. The gun-objective distance is the principal controlling factor. The technique of dive targets indicates that approximately a 70° dive is the most practical angle of dive. Their most practical speed has proved to be from 250 to 300 miles per hour, or 125 to 150 yards per second of travel. Four charts should be available for gun-objective distances of 100, 300, 500, and 1,000 yards. If additional time is available two additional charts may be calculated and plotted for gun-objective distances of 200 and 750 yards. For discussion of maximum range, see paragraph 70*i*.

■ 70. CALCULATION OF LEAD CHARTS.—*a*. Decide on the angle of dive (γ) and the most probable speed of the target.

b. Locate the gun with respect to the objective, such as 100 yards away, as shown in figure 32.

c. Using a sheet of paper, locate the objective in the center. Draw a vertical line through the objective to both the top and bottom margins of the sheet. On the lower side of the objective, on the vertical line, locate (to the scale of the drawing) the position of the gun. Call that portion of the line, objective to gun, the zero orienting line. This line will be seen as zero degrees (0°) in figure 32.

d. With the objective as a center construct radiating lines every 30° from the orienting (zero degree) line. Label these lines 30° , 60° , 90° , 120° , and so forth in a clockwise and counterclockwise direction from the zero line. These lines represent typical courses that may be flown by dive bombers attacking the objective.

e. (1) Calculate the R_m for all courses from 30° to 150° . Figure 32 shows this calculation for 30° , 60° , 120° , and 150° . The R_m of a 90° course is the distance, gun-objective, while on a 0° or 180° course, it is zero. It should be noted that the R_m on the 120° and 150° course is laid out to a point on the course extended through and beyond the objective.

(2) R_m is determined as follows: In the horizontal right triangle $O-G-MP$, the side a is known (gun-objective distance), and the angles O and G are known. Thus, the side R_m can be calculated as follows: $R_m = a \sin 30^\circ$. The side g

(objective-midpoint) may be calculated as: $g = a \cos 30^\circ$. The same calculation is used to determine the 60° , 120° , and 150° radii.

f. (1) Calculate H_m of the same courses for which R_m was determined. Figure 33 shows R_m and H_m . H_m is found as follows:

(2) In the vertical triangle $T-O-MP$, angle O is equal to 70° (angle of dive), and angle T is thus equal to 20° . With

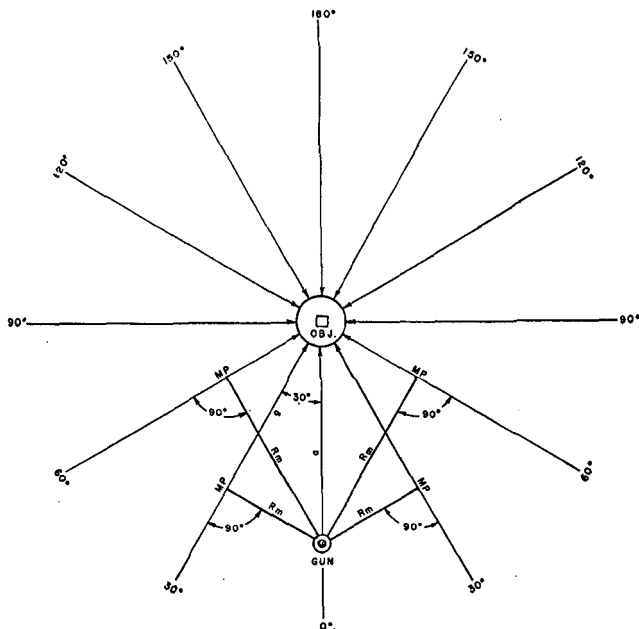

FIGURE 32.—Lead chart showing construction of R_m .

the side g determined as above, $H_m = g \tan 70^\circ$. This same calculation is used to determine H_m for 60° , 120° , and 150° courses. It should be noted that H_m on the 120° and 150° courses is also laid out to a point on the course extended through and beyond the objective. This position corresponds

to a minus ($-$) H_m as shown in figure 33. (Minus H_m is shown by construction and by arrow pointed downward on the 120° and 150° courses.)

g. Calculate all leads using Calculation Form No. 2 for coming-diving courses and Calculation Form No. 4 for cross-

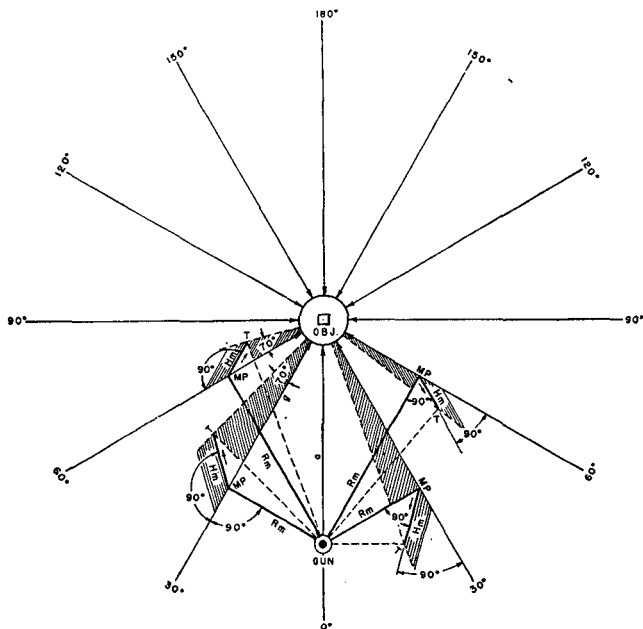

FIGURE 33.—Lead chart showing construction of R_m and H_m .

ing-diving courses, chapter 3. Two courses will be calculated as coming-diving courses (0° and 180°). Five courses will be calculated as crossing-diving courses (30° , 60° , 90° , 120° , 150°).

NOTE.—In addition to these courses it will be necessary to calculate the vertical and lateral leads for the 15° course because the leads are changing very rapidly on this course. For the same reason, the lateral but not the vertical lead must be calculated for the 165° course. However, these radii (15° and 165°) are used only as construction lines and are not drawn in on the completed chart.

h. (1) Continue the computation of leads according to the form. For determination of value of line 12, Calculation Form No. 4, first plot the D_p and L_p curves on a large sheet of cross-section paper. A sheet 18 inches by 24 inches is convenient. Plot D_p as the ordinate to a scale of 1 inch=400 yards. Plot L_p as the abscissa to the scale of 1 inch=200 yards. Connect all plotted points to construct D_p-L_p curve. Figure 34 illustrates the method of this plotting. On the D_p-L_p plot above, consider L_o as abscissa and D_o as ordinate. With the values of plotted D_p and L_p , read values of D_o from the curves for the value of L_o . From L_o as abscissa, read vertically to a point on the curve, then read D_o horizontally from the ordinate scale.

i. In order to calculate the limit of maximum range, measured from the midpoint, L_p must be obtained. To secure L_p read horizontally from the point on the ordinate scale where $D_p=2,500$ yards (a value which represents the approximate maximum slant range). When the 2,500-yard D_p horizontal line meets the curve, follow a vertical line to the bottom of the chart and read L_p on the abscissa. Then calculate L_o from the formula $L_o=L_p+Sgt_p$. To compute t_p enter firing tables with $D_p=2,500$ yards as one argument and the approximate value of ϵ_p at this point as the other argument.

NOTE.—Greater and lesser values than 2,500 have been calculated for D_p on Form No. 4 with the corresponding angular height for each. Thus, by interpolation, an approximate value of ϵ_p when $D_p=2,500$ may be determined.

j. As the objective of the diving target is known, it is easier to estimate the course and future position of the target along its line of dive by reference to this objective, rather than to have the adjuster make an estimate of the midpoint. Thus, leads are calculated as for an ordinary diving course, using the distance L_o from the midpoint to the present position of target, *but leads are referred to the objective by adding or subtracting the distance, midpoint-objective, to the distance L_o .* This gives the horizontal distance from the objective to the present position of the

target (T_o). This distance, objective to present position of target, is called L_d and is obtained from the formula—

$$L_d = L_o \pm L_m$$

in which

L_d = horizontal distance T_o -objective

L_m = horizontal distance MP -objective

It must be noted that—

$L_d = L_o + L_m$ when $\angle TOG < 90^\circ$

$L_d = L_o$ when $\angle TOG = 90^\circ$

$L_d = L_o - L_m$ when $\angle TOG > 90^\circ$

$$S_0 = 51.3 \text{ YDS/SEC}$$

$$\gamma = 70^\circ$$

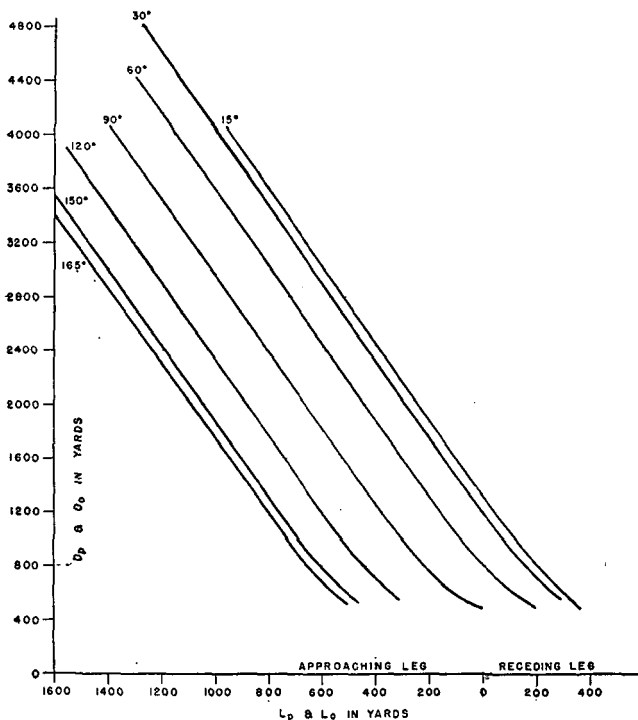

FIGURE 34.—Plot of D_p and L_p curves, gun-objective distance 500 yards.

Calculation Form No. 4 is completed to determine the lateral and vertical leads. It is recommended that all calculations and plotting for a course be completed before entering on computation for the next course, provided that calculations and plotting are consistent.

k. (1) Lateral and vertical curves are then plotted against L_d , with the lead curves as the vertical scale and L_d as hori-

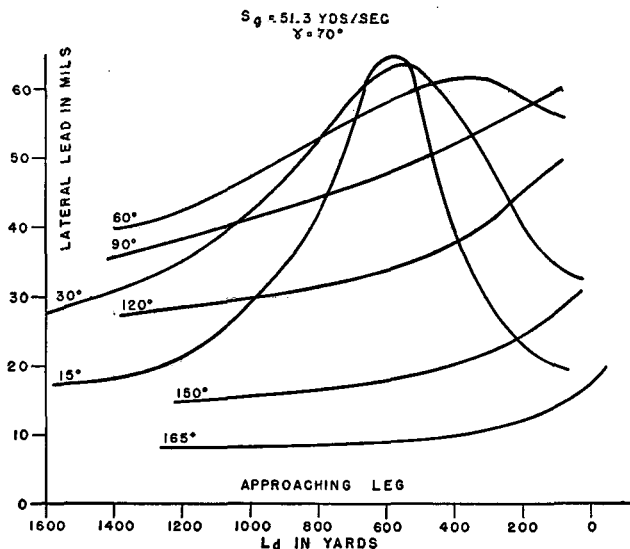

FIGURE 35.—Plot of lateral lead curves against L_d in yards, gun-objective distance 500 yards.

zontal scale. A suitable scale for use in plotting L_d is 1 inch=200 yards; and for leads, 1 inch=10 or 20 mils, depending on the range of variation of leads. Figures 35 and 36 illustrate the plotting of the leads against L_d .

(2) From these curves, values of L_d in yards for even 5-mil and 10-mil increments of lead may be read.

(3) It should be noted that a projection of the target's course in the vertical plane shows R_d (horizontal distance

from T_o to objective) for 0° course to be greater than R_d for 180° course. Figure 37 indicates this difference. The

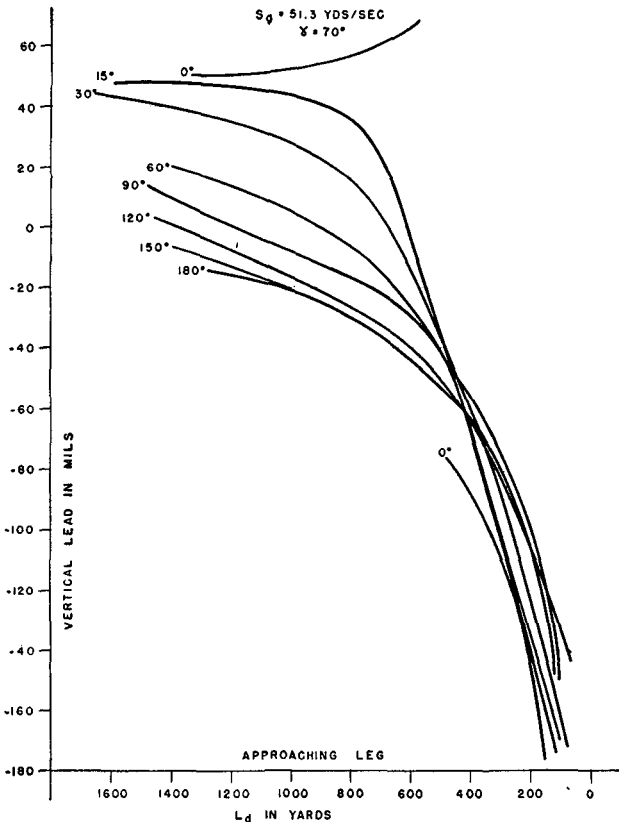

FIGURE 36.—Plot of vertical lead curves against L_d in yards, gun-objective distance 500 yards.

formula for R_d is $R_d = R_o \pm \text{distance gun-objective}$, in which $R_o = R_p + S_g t_p$. As will be seen from figure 37, the distance gun-objective is added to R_o for 0° course. However, for a

180° course, the distance gun-objective is subtracted, reducing the value of R_d .

1. Plot on the chart the vertical and lateral leads in terms of L_d in yards for each 5-mil increment. (It is more satis-

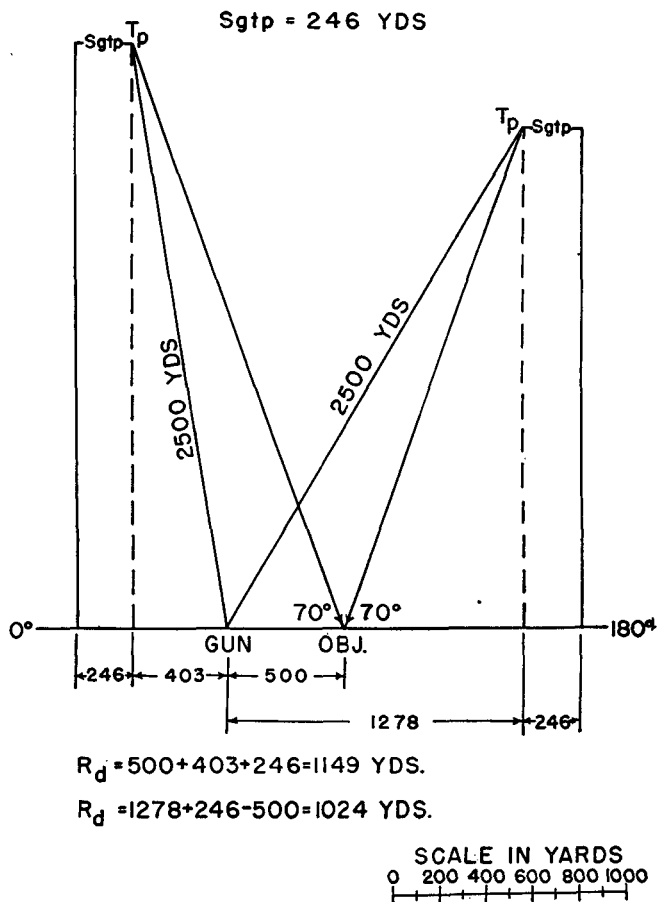

FIGURE 37.—Coming-diving target, vertical plane, gun-objective distance, 500 yards.

factory to construct separate charts for vertical and lateral leads.) L_d is measured along each ray to the scale of 1 inch=200 yards. The initial lead (read as ordinate on lead- L_d plot) is plotted on the proper ray at distance from objective equal to value of L_d in yards (read as abscissa on lead- L_d plot). Similarly, enter lateral or vertical lead for each 5-mil increment in terms of L_d . Complete the plotting of lateral and vertical leads for all rays.

m. All points of equal lead on chart are connected to construct isolead curves.

n. Lay off on each ray the limit of maximum range, obtained as in *i* above. Connect with a smooth curve all of these points.

o. Draw a circle around objective 100 yards in radius. Leads have been computed for this area but are not plotted, for it is assumed, in this study, that the dive target will level off and pull out of dive when H_p is 1,000 feet. (See figs. 24, through 31.)

p. As the 37-mm has a maximum elevation of only 85° , a dead space exists over each weapon. The area of the dead space depends on the value of H_m on the 0° ray. The 5° angle ($90^\circ-85^\circ$) at the gun describes a circle of dead space in the air. The radius of the circle equals the product of tangent 5° and H_m . This dead space circle above the gun is drawn in on the chart. For gun-objective distance of 100 yards, the area of dead space is relatively small, but for greater gun-objective distances, this dead space area becomes increasingly larger.

■ 71. COMPARISON OF CHARTS, VARYING GUN-OBJECTIVE DISTANCE.—Upon completion of all charts for gun-objective distance of 100 to 1,000 yards, it will be observed that an increase in gun-objective distance has the immediate effect of making the pattern of similar leads more intricate and complicated, indicating a rapidly changing rate and consequently a more difficult problem for the adjusters in making estimates of leads. Consequently, it may be stated that if the tactical situation permits, and if target is primarily the dive bomber, a gun should be placed as near as possible to area being defended (not closer than 100 yards).

■ 72. APPLICATION TO TRAINING OF PERSONNEL.—*a.* A careful inspection of the lead chart for dive targets reveals a number of definite advantages and characteristics for getting a stream of fire upon the target more speedily and in holding it there during the course of the target. These charts are to be used in training to familiarize the adjusters and gunners with the leads at various angles of approach, angle of dive, and speed. The chart offers a practical and useful means of estimating an initial lead, rates of change of leads, and the time in which the plane will be under fire. These advantages may be realized for any possible line of approach of the dive target.

b. Furthermore, such a chart becomes most profitable when it is oriented for certain prominent features of the terrain about the gun installation. It is suggested that these prominent landmarks be indicated on the oriented lead chart. Thus, the chart is oriented for a line of approach of the plane over a schoolhouse, a hill, a church steeple, a high tree, and so forth. The adjusters can readily apply accurate initial and "following" leads just as soon as the target appears over or near one of these terrain features. Personnel may become familiar with rates of change of leads over oriented course, the sign (+ or -) of the leads, and the limit of time in which the target will be subject to fire. Inasmuch as no satisfactory diving target has as yet been developed for actual firing practice, training of adjusters by using oriented charts becomes especially advantageous.

CHAPTER 5

LEAD CHARACTERISTICS

■ 73. GENERAL.—From a study of lead curves and charts for various target courses and speeds, conclusions can be drawn as to the general characteristics of leads required for automatic weapons (see par. 59 for definitions).

a. Coming courses.—(1) On a true coming course, the lateral lead is zero. Any place where R_m is equal to or less than 100 yards, lateral lead is negligible and may be disregarded so far as computed leads are concerned.

NOTE.—In actual firing a small lateral pointing correction may be required for targets which do not pass directly over the gun position.

(2) When the target is flying at a constant altitude, the vertical lead curve is positive throughout the approaching leg of the course. On the receding leg the lead curve approaches a straight line starting near the midpoint with a large initial negative value. It remains negative throughout the receding course except for a slight positive value far out on the course beyond the range of fire.

b. Crossing courses.—(1) Lateral leads for right-to-left courses are always to the left of the target, and for left-to-right courses are always to the right of the target.

(2) On crossing courses the lateral lead starts with the least positive lead on the approaching leg, reaches a maximum at approximately the midpoint, and then decreases on the receding leg.

(3) Vertical leads are at their maximum positive value at the start of the approaching leg and decrease positively, pass through zero, and then increase negatively until the target is well past the midpoint of the course, the rate of change being very great. After reaching their maximum negative value they decrease negatively, sometimes passing through zero again and increasing positively before the target passes beyond range.

c. Lead characteristics.—The remainder of this chapter is a discussion of lead characteristics for the 37-mm gun. The characteristics for other automatic weapons are similar.

■ 74. COMING-CONSTANT ALTITUDE COURSES.—*a.* The vertical lead for coming-constant altitude courses is affected by two

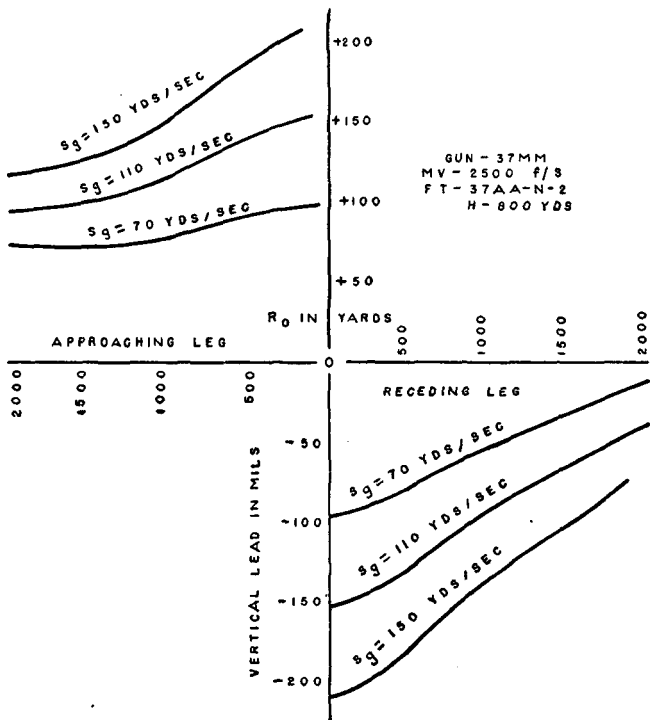

FIGURE 38.—Variation in target speed, coming-constant altitude course.

variable elements of data, target speed and altitude of the target.

b. From figure 38 it can be seen that an increase in target speed on a coming-constant altitude course causes a large

increase in the required initial vertical lead and an increase in the rate of change of leads. The rate of change of leads is increased as the slope of the lead curve becomes steeper.

c. Figure 39 shows that, as the altitude is increased, the initial vertical lead must be increased. At the shorter ranges

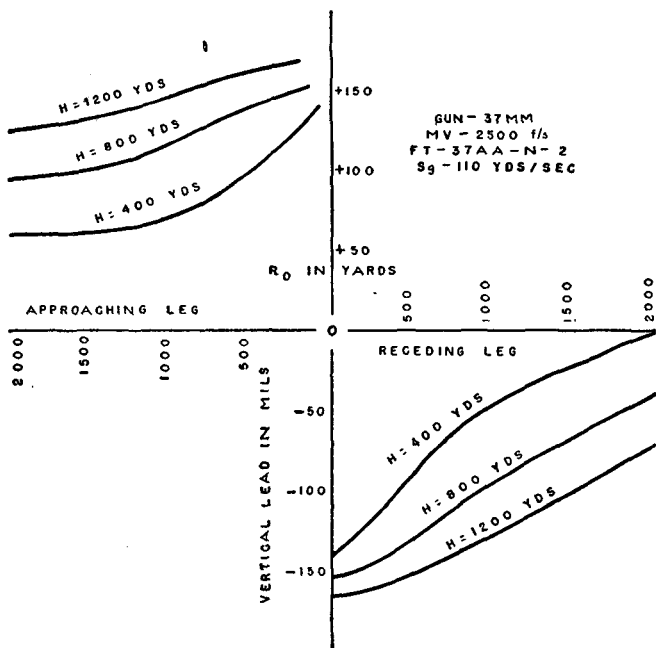

FIGURE 39.—Variation in altitude, coming-constant altitude course.

the rate of change of leads is decreased as the altitude is increased, but at the longer ranges the rates are nearly the same. The rates are the same where the lead curves are parallel to each other.

d. Note from both figures 38 and 39 that the extreme change in leads from a large positive to a large negative value occurs as the target passes overhead and thus makes any attempt

to fire at that point of the course impracticable for several seconds. Limitations of the gun mounts (maximum elevation of the 37-mm gun is 85° ; maximum elevation of machine guns is 70° to 80°) also prevent fire on this part of course.

■ 75. COMING-DIVING COURSES.—*a.* (1) The vertical lead for coming-diving courses is affected by three elements of data: target speed, angle of dive, and the distance H_m .

(2) Three general situations must be considered: first, where the target dives at the gun position; second, where the target passes over the gun position while diving at a point in rear of the gun; and third, where the target dives at a point in front of the gun so that the gun must be fired across the objective at the approaching target.

b. Figures 40 and 41 show that when the target dives directly at the gun position ($H_m=0$), the initial vertical lead is small and decreases to zero at the theoretical conclusion of the dive. In these courses, e_p is always equal to e_0 , therefore the vertical lead is equal only to superelevation. These figures also show that there is very little change in the lead for either a change in target speed or a change in angle of dive when H_m is zero. With no lateral lead, and with vertical leads small and changing slowly, this target is an ideal automatic weapons target, providing the tactical situation permits emplacement of the gun near the objective.

c. Figures 40 and 41 also show the effect of target speed and angle of dive on vertical leads for courses having $H_m=400$ yards and $H_m=800$ yards (objective in rear of gun). As in the case of coming-constant altitude courses, an increase of target speed increases the initial vertical lead and slightly increases the rate of change of leads. As angle of dive is decreased, the initial vertical lead and rate of change of lead increase somewhat. *The sharp angle at which the leads increase on the receding leg of the course shows conclusively that any attempt to track on the target on this type of course after it passes overhead is practically useless.* Therefore a decision may be made to put up a fixed or semifixed barrage on the receding leg.

d. Figures 42 and 43 show the effect of changes in target speed and angle of dive when the objective is in front of

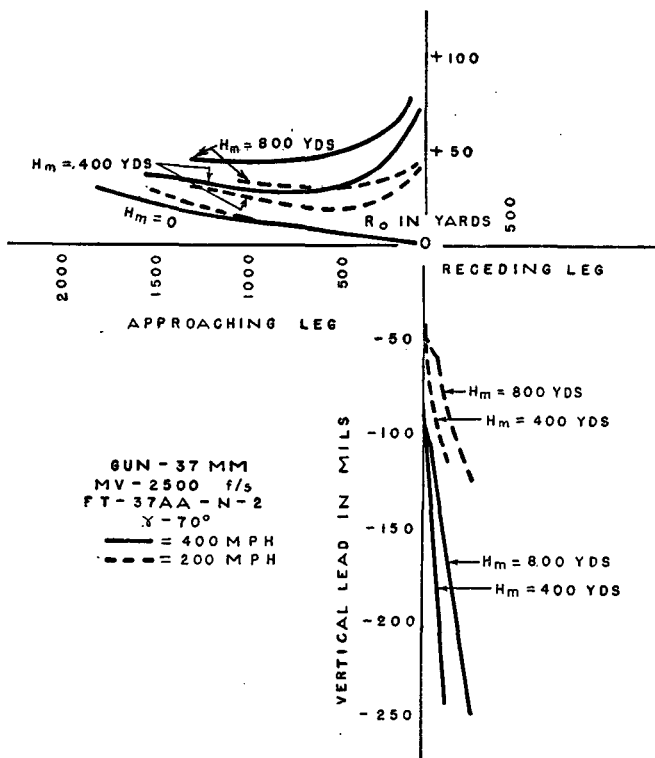

FIGURE 40.—Variation in target speed and in H_m , coming-diving course.

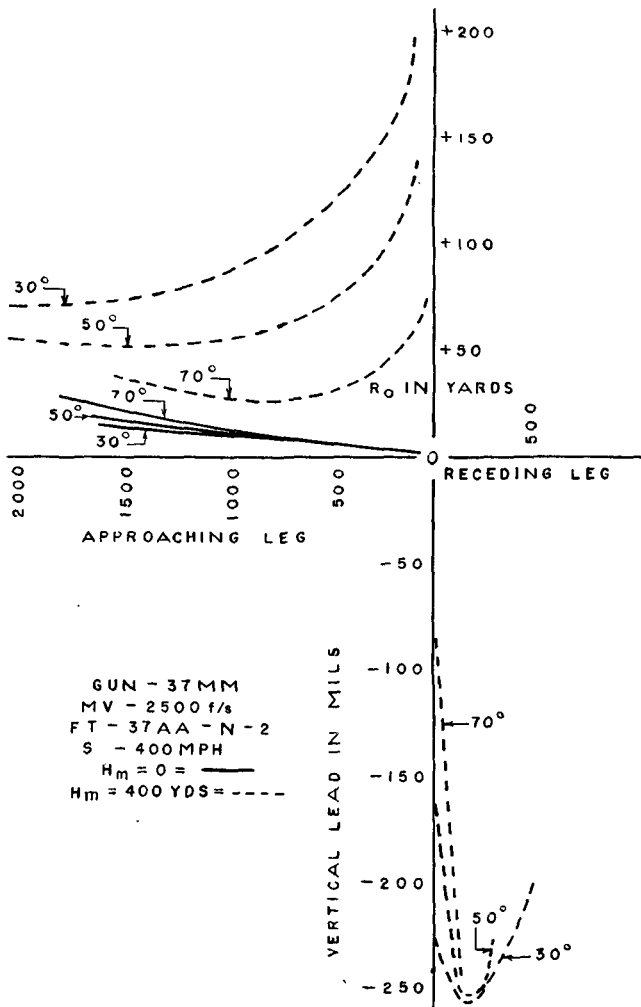

FIGURE 41.—Variation in angle of dive, coming-diving course.

the gun. In both cases the leads are smaller and change less rapidly at the longer ranges. The initial vertical lead becomes negative sooner as the target speed increases, but rate of change of leads remains the same. All angles of

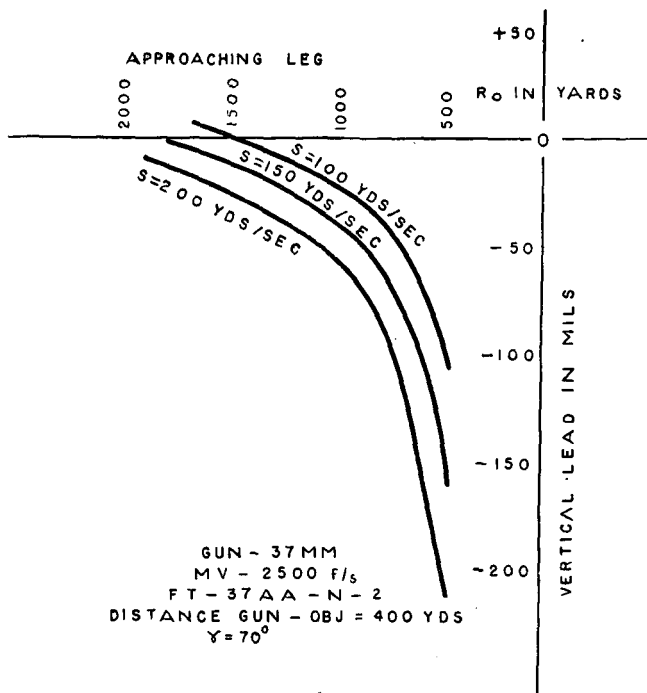

FIGURE 42.—Variation in target speed, coming-diving course, objective in front of gun.

dive from 30° to 70° require about the same initial vertical lead, but rates of change of leads are greater as the angle of dive is changed from 30° to 70° . Near the objective, the leads are normally changing too rapidly to permit effective fire.

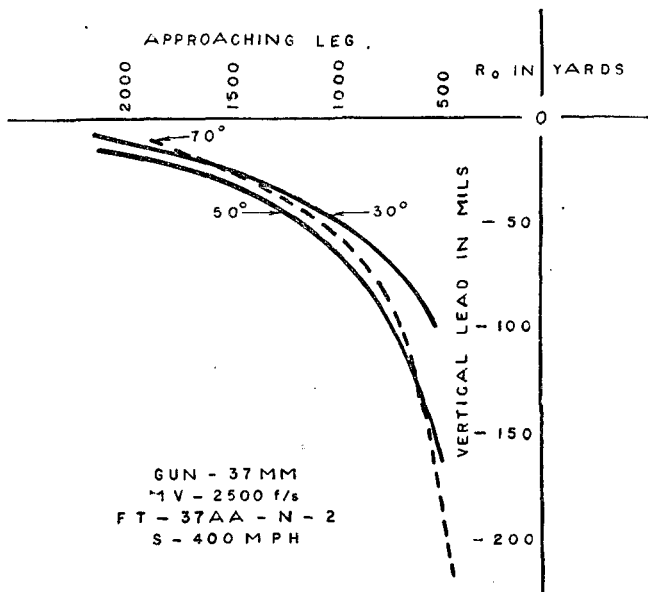

FIGURE 43.—Variation in angle of dive, coming-diving course, objective 400 yards in front of gun.

76. CROSSING-CONSTANT ALTITUDE COURSES.—The values of three elements of data determine the lateral and vertical leads for crossing-constant altitude courses. These are target speed, altitude, and horizontal range to the midpoint of the course. Their effects on the lateral lead are shown in figures 44, 45, and 46. Their effects on the vertical lead are shown in figures 48 to 52, inclusive.

a. *Lateral lead.*—(1) Figure 44 shows that an increase of 80 yards per second in target speed calls for a large increase in the initial lateral lead and a small increase in the rate of change of leads. The point of maximum lead with relation to the midpoint of the course is not materially changed.

(2) Figure 45 shows that for both service and target practice speeds a change of 400 yards in altitude causes only a small change in the initial lateral lead and almost no change

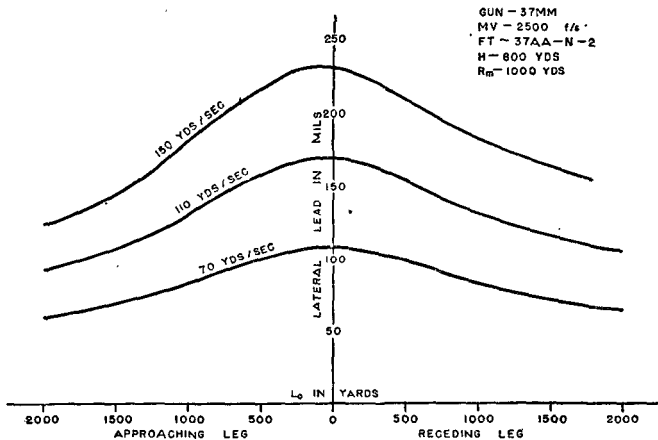

FIGURE 44.—Variation in target speed, crossing-constant altitude course (lateral lead).

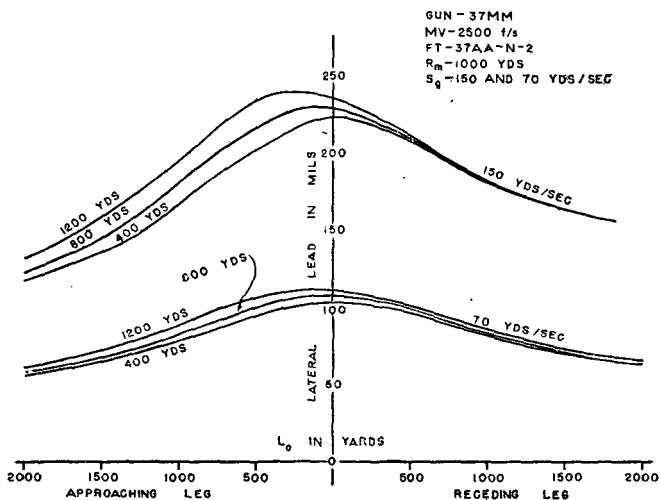

FIGURE 45.—Variation in altitude, crossing-constant altitude course (lateral lead).

in the rate of change of leads. Particularly at service speeds, the point of maximum lead occurs earlier on the course as the altitude is increased.

(3) Figure 46 shows that for both service and target practice speeds, an increase (decrease) of 400 yards in horizontal range to the midpoint causes a large increase (decrease) in the initial lateral lead and a considerable decrease (increase)

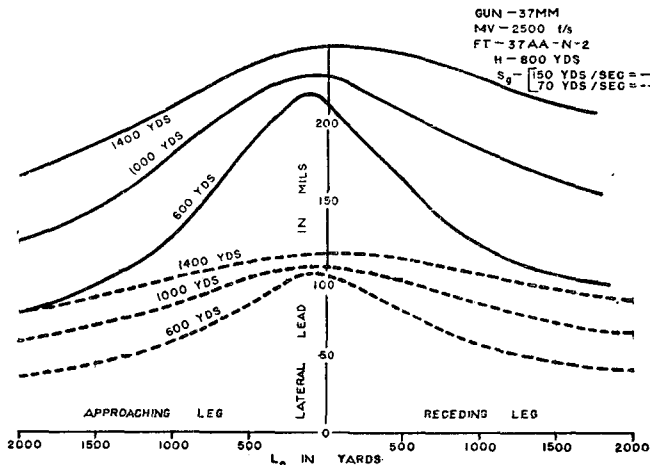

FIGURE 46.—Variation in horizontal range to midpoint, crossing-constant altitude course (lateral lead).

in the rate of change of the lead. The point of maximum lead remains near the midpoint.

(4) Figure 47 shows how an incorrect estimation of angle of approach (incorrect location of midpoint) causes gun to shoot either ahead of or behind the target. If this error is made, the only point at which the adjuster will be on the target will be at the midpoint. If the midpoint has been estimated to the right, the gun will fire behind the target on the approaching leg and ahead on the receding leg. The error will be reversed if the midpoint is estimated to the left.

b. *Vertical lead.*—(1) Figure 48 shows that the vertical lead becomes more positive on the approaching leg and more nega-

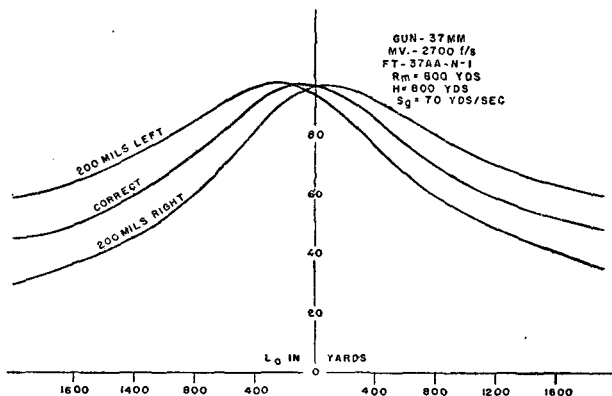

FIGURE 47.—Effect on lateral lead of incorrect estimation of angle of approach, crossing-constant altitude course.

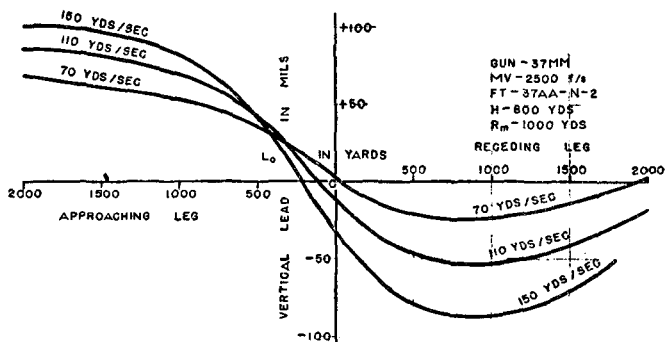

FIGURE 48.—Variation in target speed, crossing-constant altitude course (vertical lead).

tive on the receding leg as the speed increases, thus making the curve for the higher speed steeper.

(2) Figure 49 indicates that an increase in altitude causes a large increase in vertical lead (both positive and negative),

and makes the curve steeper. The effect is the same as for an increase in speed.

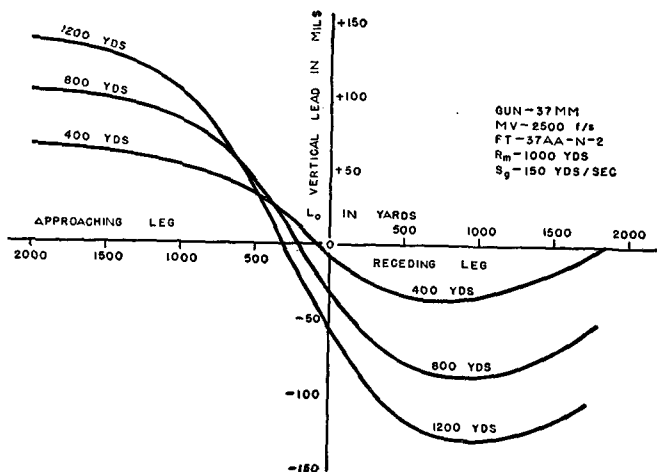

FIGURE 49.—Variation in altitude, crossing-constant altitude course at service speed (vertical lead).

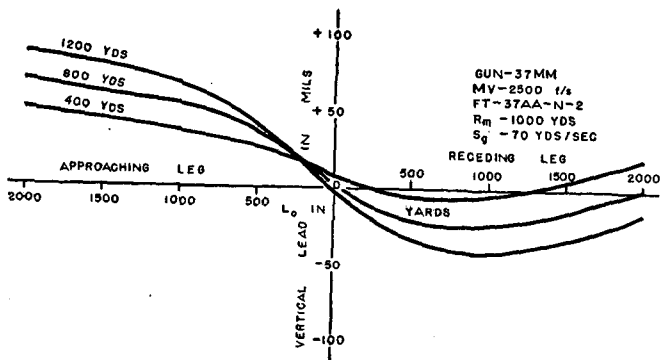

FIGURE 50.—Variation in altitude, crossing-constant altitude course at towed target speed (vertical lead).

(3) Figure 50 shows the same effects as in figure 49. It is to be noted, however, that with a slower speed, the vertical

leads are smaller (both positive and negative) and the curves are flatter.

(4) Figure 51 shows that as range to the midpoint (R_m) is decreased, the vertical lead is more positive on the approaching leg and more negative on the receding leg. Thus, the greatest rate of change of leads will occur on targets

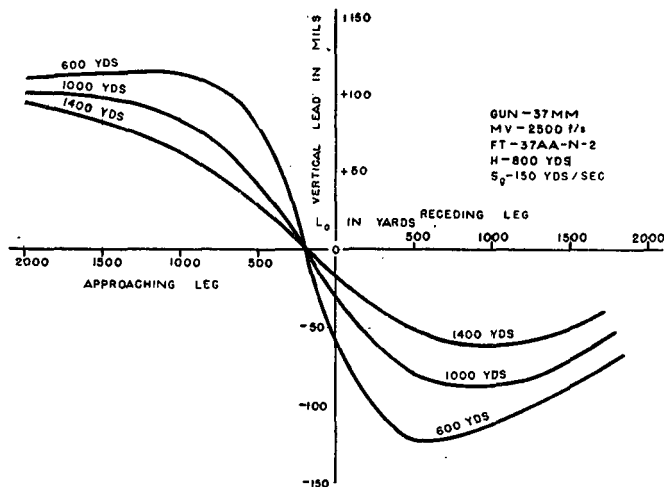

FIGURE 51.—Variation in R_m , crossing-constant altitude course at service speed (vertical lead).

closest to the gun position, since the curve becomes steeper as R_m is decreased.

(5) Figure 52 shows that the initial vertical leads are nearly the same for all targets whose range to the midpoint is between 600 and 1,400 yards. As the target approaches the midpoint, the rate of change of the vertical lead is greatest on the closer target; that is, the change in the vertical lead is in inverse proportion to the change in R_m . An increase in R_m decreases the lead, makes it less positive on the approaching leg and less negative on the receding leg, thus making the curve for the greater R_m flatter. Close

to midpoint (approaching), curves pass through an identical point.

(6) Figure 52 is similar to figure 51, except it is calculated for approximately one-half the speed. The decrease in speed

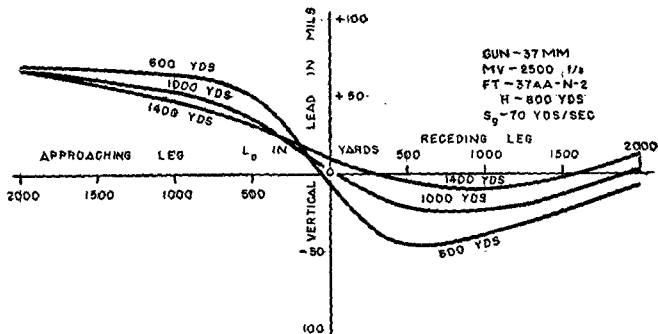

FIGURE 52.—Variation in R_m , crossing-constant altitude course at towed target speed (vertical lead).

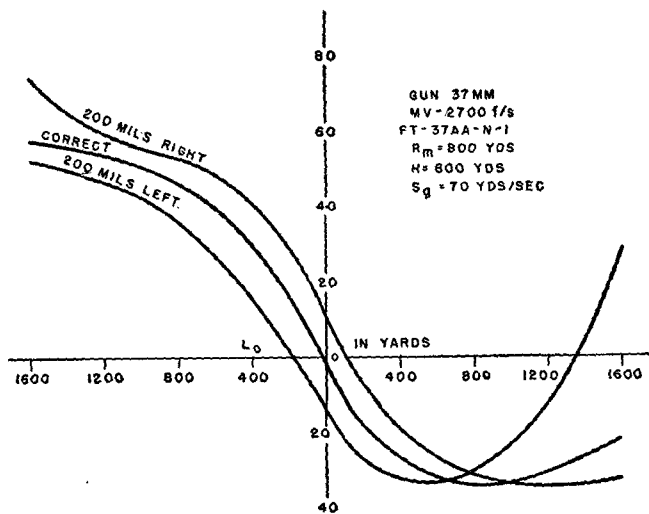

FIGURE 53.—Effect on vertical lead of incorrect estimation of angle of approach, crossing-constant altitude course.

indicates a smaller initial vertical lead. However, the characteristics of the curves are similar to those in figure 51. Generally, the rate of change of the vertical lead is also less at the slower speed.

(7) Figure 53 shows how the incorrect estimation of the angle of approach (incorrect choice of midpoint) causes the trajectory to be below or above the target. If the midpoint is incorrectly estimated to the left, the vertical lead will cause the trajectory to be below the target during the approaching leg and a considerable distance out on the receding leg. If the midpoint were incorrectly estimated to the right, the errors would be reversed.

■ 77. CROSSING-DIVING COURSES.—The leads for crossing-diving courses are affected by four elements of data. These

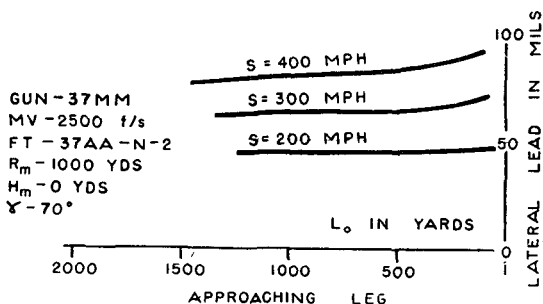

FIGURE 54.—Variation in target speed, crossing-diving course (lateral lead).

are speed of the target, altitude at the midpoint, range at the midpoint, and the angle of dive. The effect of lateral lead is shown in figures 54 to 57, inclusive. The effect on vertical lead of changing elements of data is shown in figures 58 to 61, inclusive.

a. Lateral lead.—(1) Figure 54 shows how an increased target speed increases the initial lateral lead. However, the rate of change of the leads for these different speeds is fairly uniform.

(2) Figure 55 indicates that a difference in altitude at the midpoint has little effect on either initial lateral lead or rate of change. As the target reaches the midpoint, the leads become erratic.

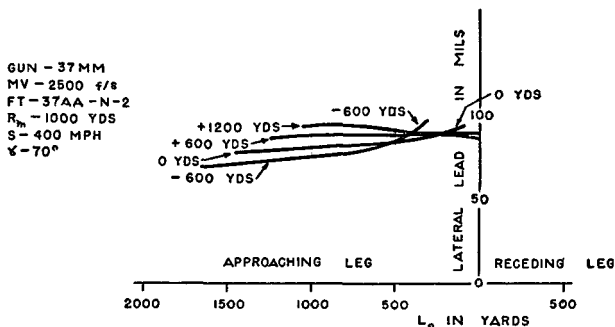

FIGURE 55.—Variation in H_m , crossing-diving course (lateral lead).

(3) Figure 56 indicates that as the range to the midpoint increases, the initial lateral lead increases while the rate of change is not seriously affected.

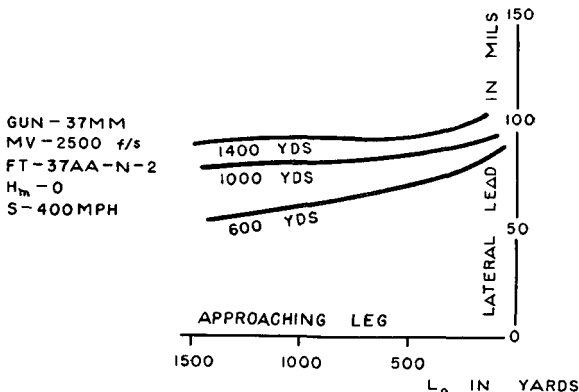

FIGURE 56.—Variation in R_m , crossing-diving course (lateral lead).

(4) Figure 57 shows how a variation in angle of dive has an extreme effect on both initial lateral lead and the rate of

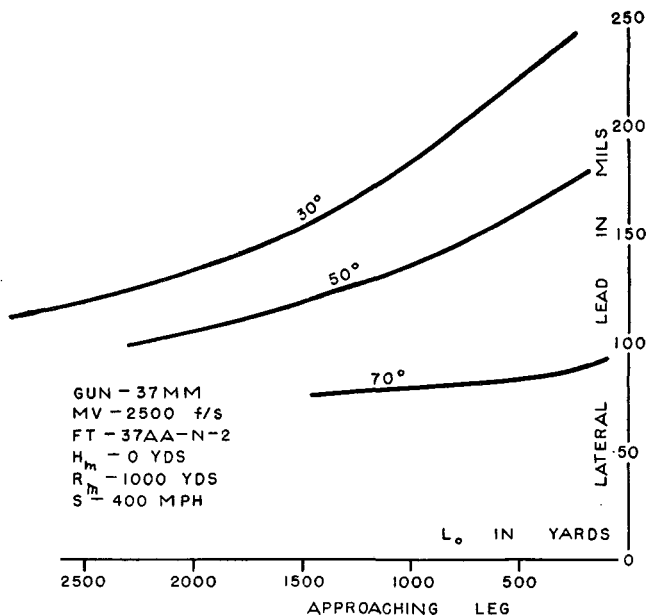

FIGURE 57.—Variation in angle of dive, crossing-diving course (lateral lead).

change of lateral lead. This extreme effect is that as angle of dive increases, the lead decreases and the curve becomes flatter.

b. Vertical lead.—(1) Figure 58 shows how an increase in target speed increases the negative initial vertical lead but the rate of change remains fairly constant.

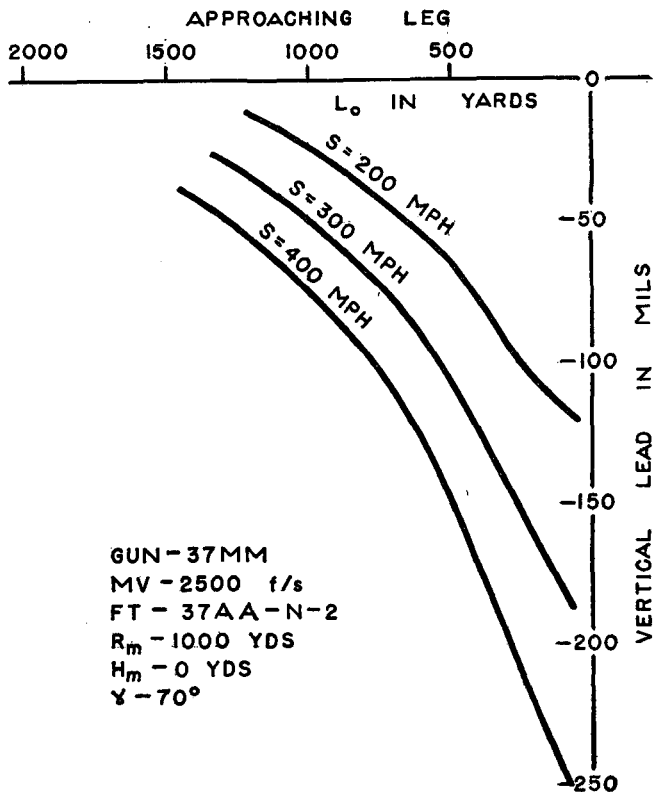

FIGURE 58.—Variation in target speed, crossing-diving course (vertical lead).

(2) Figure 59 shows how an increase in altitude of the midpoint on a crossing-diving course causes the initial lead to become less negative but the rate of change of leads is not materially affected.

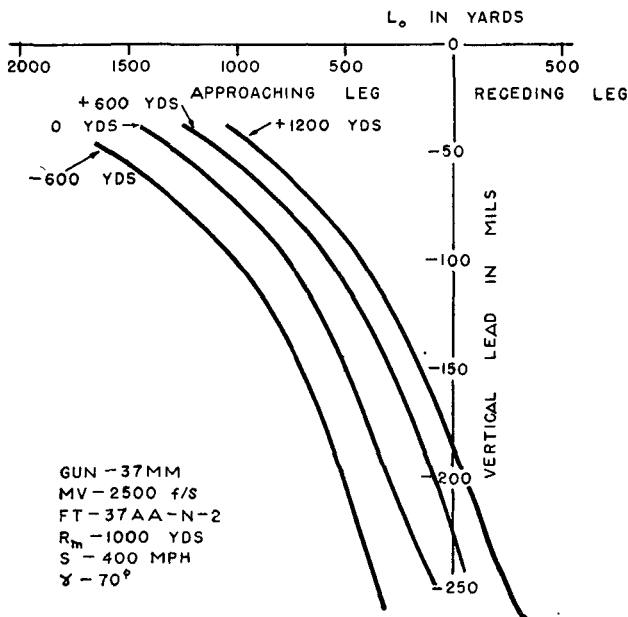

FIGURE 59.—Variation in H_m , crossing-diving course (vertical lead).

(3) Figure 60 shows how an increase in horizontal range to the midpoint causes vertical lead to become more negative. It also shows how a variation in horizontal range to the midpoint causes a large difference in initial leads, while the rate of change of lead is fairly uniform.

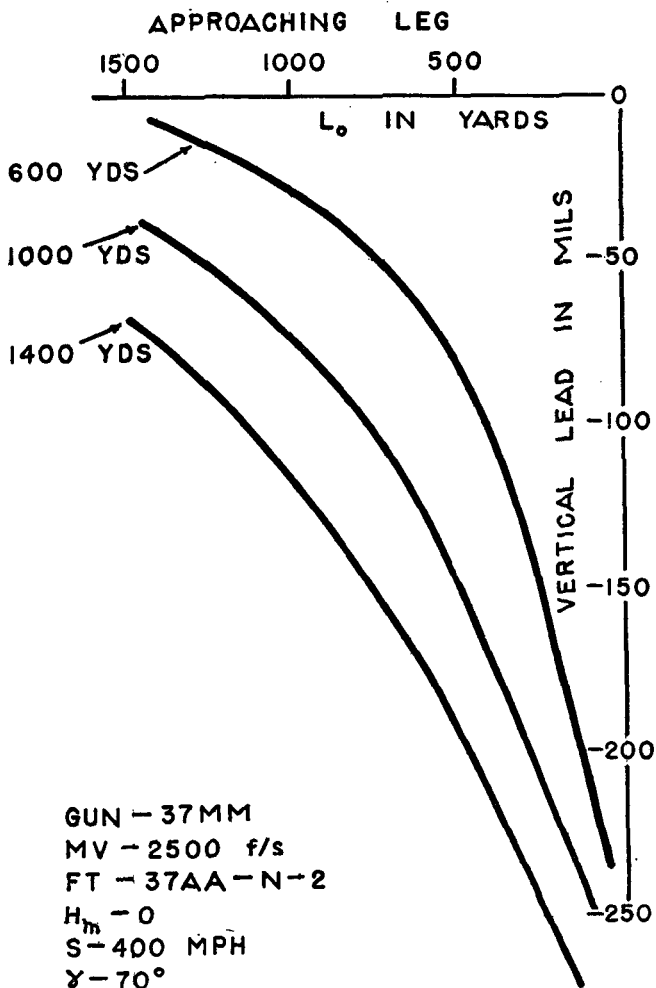

FIGURE 60.—Variation in R_m , crossing-diving course (vertical lead).

(4) Figure 61 indicates that a variation in angle of dive has a small effect on initial vertical lead. The rate of change of these leads is fairly uniform except at the closer ranges.

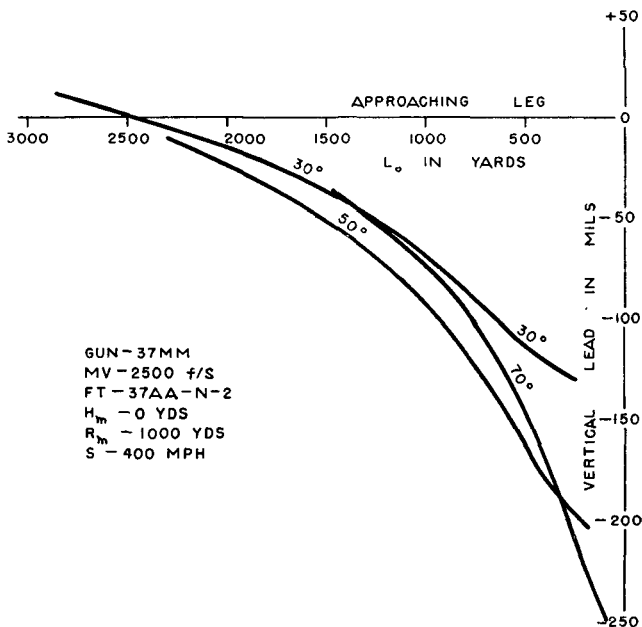

FIGURE 61.—Variation in angle of dive, crossing-diving course (vertical lead).

■ 78. DIFFERENTIAL EFFECTS.—*a. General.*—The differential effects from standard conditions (muzzle velocity, ballistic density, and wind) are shown in the differential effects tables of FT 37-AA-N-2.

b. Muzzle velocity.—Of the three conditions for which differential effects are provided, muzzle velocity varies most uniformly. It can be predicted fairly accurately before firing

is to take place. Figures 62, 63, and 64 show that on both coming and crossing courses, the effects of variations in muzzle velocity are quite uniform throughout the course.

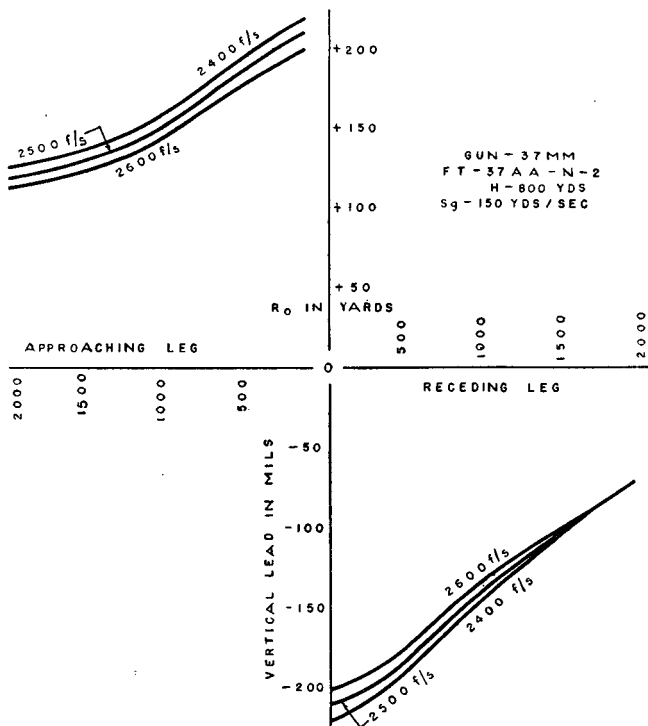

FIGURE 62.—Variation in muzzle velocity, coming-constant altitude course (vertical lead).

They indicate that for a 37-mm gun the lateral and vertical leads, whether negative or positive, should be increased about 5 percent for each 100 foot-seconds decrease in muzzle velocity.

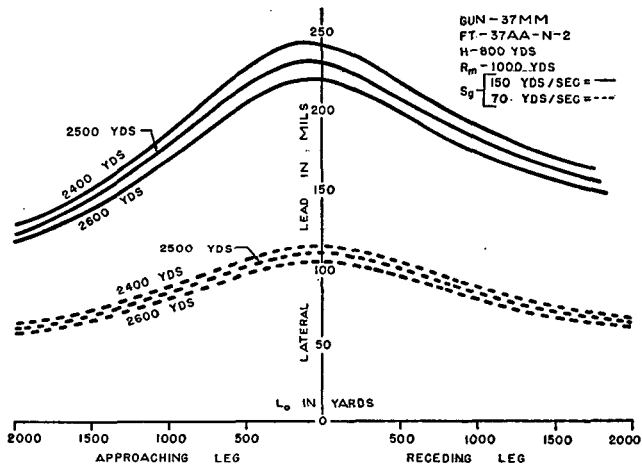

FIGURE 63.—Variation in muzzle velocity, crossing-constant altitude course (lateral lead).

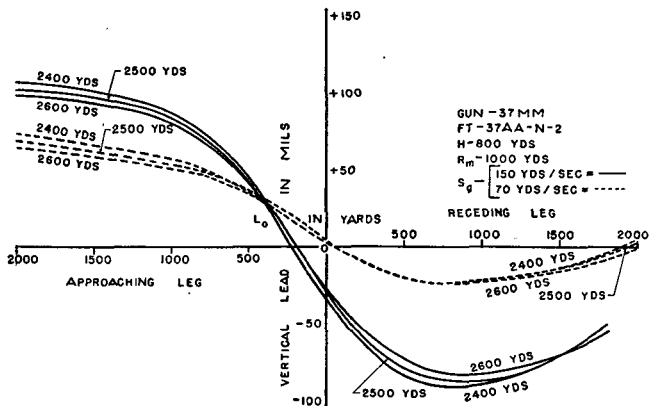

FIGURE 64.—Variation in muzzle velocity, crossing-constant altitude course (vertical lead).

c. *Ballistic density.*—The effects of ballistic density as shown in figures 65 to 67, inclusive, are not as uniform as those of muzzle velocity. However, they indicate roughly a 4-percent increase in leads for each 10-percent increase

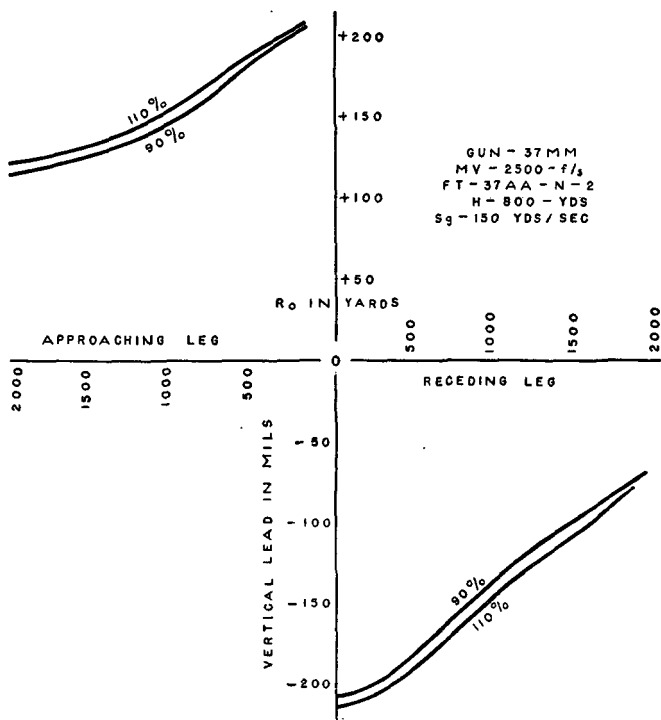

FIGURE 65.—Variation in ballistic density, coming-constant altitude (vertical lead).

in ballistic density. This approximation may be accepted with considerable reliability. A series of calculations in which are made such approximations of the effects of ballistic density changes upon leads (applied in terms of percentage effects on leads) conforms closely to computations of differential effects on times of flight and superelevations taken

from firing tables. However, as data on ballistic density may not be readily available to an automatic weapons platoon,

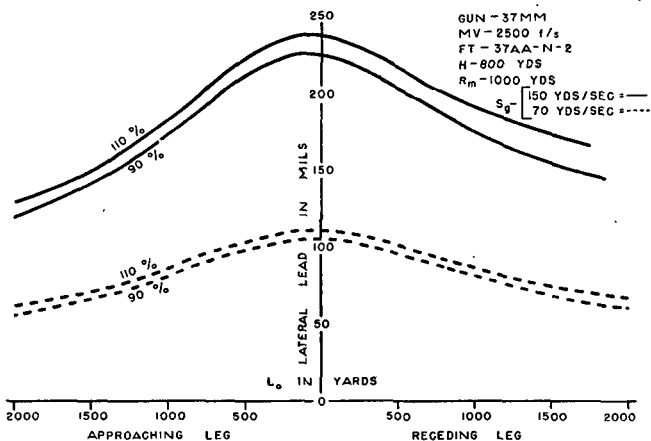

FIGURE 66.—Variation in ballistic density, crossing-constant altitude course (lateral lead).

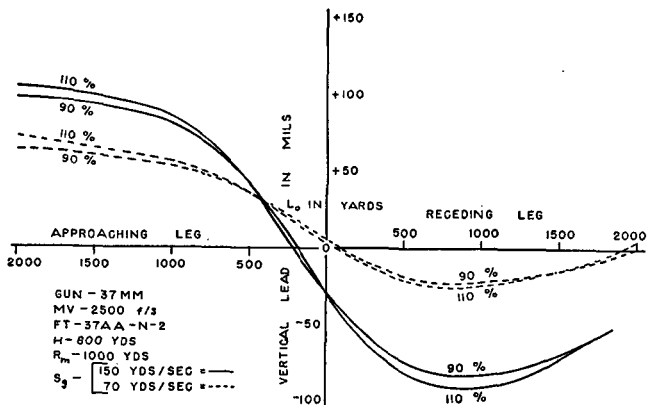

FIGURE 67.—Variation in ballistic density, crossing-constant altitude course (vertical lead).

the disregarding of this effect appears fully justified, except in case of an extreme change, in which case a correction

such as that above should be made. Such wide variations will hardly be encountered in the continental United States. If, in other latitudes, a variation of ± 10 percent in ballistic density occurs, a flat correction to leads, as above, should be applied.

d. Wind.—Wind effects as indicated by figure 68, where usable, are so small as to make consideration of this condition a useless refinement of approximate data. As stated in chapter 3, they cannot be used at all on crossing courses except in a few special cases.

■ 79. LEAD CORRECTIONS FOR DIFFERENTIAL EFFECTS.—*a. General.*—The following calculations indicate that corrections for ballistic density, muzzle velocity, and powder temperature may be made after leads for standard conditions have been calculated:

(1) *Ballistic density.*

10 percent increase=4 percent increase in leads.

10 percent decrease=4 percent decrease in leads.

(2) *Muzzle velocity.*

100 f/s decrease=5 percent increase in leads.

100 f/s increase=5 percent decrease in leads.

(3) *Powder temperature.*—The formula is: (temperature of powder -70°) \times proper MV factor for the gun being used. $A+1^\circ$ F. change in powder temperature from the normal 70° F. gives a+MV in accordance with the table below. $A-1^\circ$ F. change reverses the sign of MV.

	<i>MV factor</i>
Caliber .30 tracer, solid and AP shot	=1.69 f/s
Caliber .50 tracer, solid and AP shot	=1.80 f/s
37-mm shell and AP shot	=1.62 f/s
40-mm shell and AP shot	=1.77 f/s

b. Muzzle velocity correction.—Developed muzzle velocity should be determined according to the following formula:

(1) *Caliber .30 machine gun.*—A new gun barrel measures 1.9 inches from the face of the breech to the back of the projectile. A barrel measures 3.0 inches from the face of the breech to the back of the projectile when 175 f/s muzzle velocity has been lost, or when approximately 6,000 rounds

have been fired. Therefore, there is a loss of approximately 3 f/s muzzle velocity per 100 rounds fired.

(2) *Caliber .50 machine gun.*—A new gun barrel measures 3.0 inches from the face of the breech back to the pro-

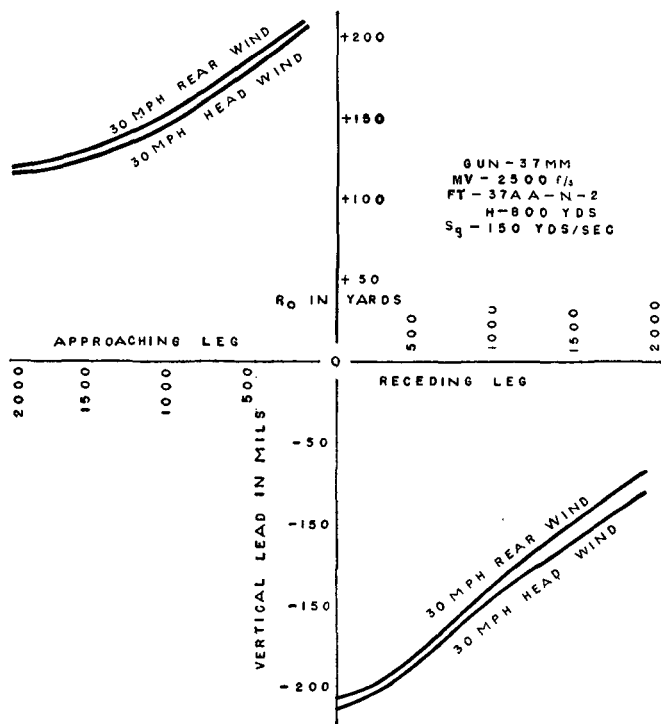

FIGURE 68.—Variation in wind velocity parallel to the trajectory, coming-constant altitude course (vertical lead).

jectile. Guns which have lost approximately 200 f/s muzzle velocity measure 6.0 inches from the face of breech to the back of the projectile. Therefore, there is an increase of approximately 1.5 inches in breech gaging for each 100f/s loss of muzzle velocity.

(3) *37-mm gun.*—According to available information, this gun loses 200 f/s muzzle velocity after approximately 3,000

rounds have been fired. Thus, there is approximately a 6 f/s loss in muzzle velocity per 100 rounds fired.

c. Method of correcting leads.—(1) Determine the muzzle velocity correction for powder temperature.

(2) Determine the muzzle velocity correction for barrel wear.

(3) Add these two muzzle velocity corrections.

(4) Determine the lead correction percentage factor due to change in muzzle velocity.

(5) Determine the lead correction percentage factor due to change in ballistic density.

(6) Add these two factors algebraically.

(7) Correct the standard leads by applying this percentage correction factor.

d. Methods.—In chapter 2 ballistic corrections were determined as a function of t_p and ϕ_s . However, it is easier to calculate leads for standard conditions and then make flat percentage corrections for ballistic changes as shown above. The latter method checks with sufficient accuracy against the former method to be advantageously used, and it is thus recommended.

■ 80. SUMMARY.—The character of the automatic weapons problem is such that a mastery of the fundamental characteristics of lead curves and of the differential effects for various types of courses is essential for the delivery of effective fire. It is also of the highest practical importance for officers and adjusters to realize that certain variables are not as important as others. Ability to estimate quickly and accurately the leads for a particular course should be instinctive. Such ability can be developed only by the analysis of lead curves and by experience. The expert "skeet" shooter has learned from long experience at the sport the proper lead to allow in order to hit the 25 "birds" from the various shooting positions. The automatic weapons adjuster has a more difficult problem in that he must not only learn the value of the proper lead, but also must learn to take into account the many conditions under which targets may appear, such as variations in altitude, speed, range, and angle of dive.

CHAPTER 6

HORIZONTAL FIRE

	Paragraphs
SECTION I. General.....	81-82
II. Antimechanized defense.....	83-86
III. Assault of fortifications.....	87-88
IV. Engagement of water-borne targets.....	89-91
V. Lateral leads and lead charts.....	92-95

SECTION I

GENERAL

■ 81. **GENERAL.**—FM 100-5 states that the antiaircraft artillery is so equipped that it can execute antitank and other ground missions when necessary. Experience in the present war indicates that these weapons are effective against mechanized targets and field fortifications. In addition, the need for weapons with a relatively high muzzle velocity and rate of fire may require the assignment of antiaircraft artillery to missions of defense against small, high speed, water-borne targets.

■ 82. **TACTICS.**—The details of the tactical employment of antiaircraft automatic weapons against land and water-borne targets are contained in FM 4-105.

SECTION II

ANTIMECHANIZED DEFENSE

■ 83. **GENERAL.**—*a. Accuracy of fire.*—Although the mechanized target has less speed and maneuverability than the airplane, when a mechanized attack does occur, the action is fast, furious, and of short duration. All personnel must realize that tanks will appear with little or no warning, and must be engaged speedily. It is essential that initial fire be accurate. If opening fire is inaccurate, the tank can easily seek another avenue of approach or may retire to a defiladed spot and neutralize the disclosed position. Also when anti-tank positions are disclosed, they may be attacked by dismounted parties.

b. Ammunition.—Although HE shell can be used effectively against some targets, armor-piercing ammunition will be required against most armored vehicles. It is contemplated that all antiaircraft armor-piercing projectiles, except the caliber .50, will be provided with a tracer element. In the case of the caliber .50 machine guns, tracer ammunition is interspersed with armor-piercing to produce a tracer stream. Muzzle velocities of armor-piercing ammunition for antiaircraft artillery automatic weapons are shown below and are the velocities developed by new guns:

Weapon	Ammunition	Muzzle velocity (f/s)
Caliber .50 machine gun.....	M1.....	2,700
37-mm gun.....	M59.....	2,050

Armor-piercing ammunition is also being developed for the 40-mm gun.

■ 84. CHARACTERISTICS OF TARGETS.—*a. General.*—Mechanized targets which the antiaircraft artillery automatic weapons may be required to engage are—

(1) *Heavy tanks (50 to 75 tons).*—These are suitable targets for the 3-inch and 90-mm guns, but normally are not vulnerable to fire from 37-mm and 40-mm guns except at very short ranges.

(2) *Medium tanks (18 to 35 tons).*—These are suitable targets for 37-mm and 40-mm guns at ranges up to 500 yards.

(3) *Light tanks and armored cars.*—These are lightly armored and are suitable targets for all antiaircraft artillery automatic weapons of caliber .50 and above.

(4) *Unarmored vehicles.*—These are suitable targets for all automatic weapons including small arms.

b. Vulnerability of tanks.—Tanks are most heavily armored on turrets and the front of the vehicle. The most vulnerable areas are the sides, bellies, tracks, and track suspension mechanisms. Every effort should be made to engage tanks so that these vulnerable points are brought under fire. To

accomplish this, flanking fire is preferable to frontal, and plunging fire is least effective. It is not necessary to demolish a tank to put it out of action. Shell fragments and small caliber bullets may penetrate vision slits or ports and destroy the crew or essential tank mechanism. Even a caliber .30 bullet fired into a turret juncture may jam the turret and prevent accurate sighting of the tank guns. At close range, small arms fire should be brought to bear on the vulnerable points mentioned above.

■ 85. TECHNIQUE.—*a. General.*—(1) In order to stop a tank it must be hit with a force sufficient to penetrate the armor, to demolish a vital part of the mechanism, or to kill the crew. In order to obtain the first effective blow, accuracy of initial fire is desired above all else.

(2) From a gunnery standpoint the accuracy of fire on a moving tank is in part a function of the muzzle velocity and the range at which the target is engaged. At short ranges the maximum ordinates of trajectories of antiaircraft automatic weapons is only a few feet. The target is usually high enough to receive hits even though small errors are made in range pointing, because of the flatness of the trajectory. Moreover, the shorter time of flight results in a smaller lateral lead. At longer ranges, not only are lateral leads greater, but smaller errors in range pointing may result in complete misses because of curvature of the trajectory.

b. Fire control.—(1) Power-trained 37-mm and 40-mm guns can be fired at ground targets with the same director control used against airplanes. By changing the position of the mechanical stops on the guns slightly, these guns can be used effectively with director control. These stops must be adjusted so the gun will cut out slightly below zero quadrant elevation; otherwise the gun is apt to cut out from power control while firing at or near zero degrees. When a power-controlled unit must suddenly engage a ground target, director control will be used.

(2) When units are controlled with central tracer equipment for antiaircraft fire, this same method may be used for antimechanized fire if only a single target must be engaged. Where more than one target must be engaged by the unit,

direct pointing by the individual gunners will be resorted to. This will be accomplished if the control box is set to normal and each gun pointer leads his target the necessary amount.

(3) Compared to airplanes, the speed of mechanized targets is low and the ranges at which these targets are engaged are short. Consequently, the leads required for fire against mechanized targets are small enough to be estimated and applied by the gun pointers.

(4) A discussion of the latter method, as it applies to the different types of automatic weapons, is contained in *c* and *d* below. All members of anti-aircraft gun crews, including ammunition details, should be so thoroughly trained in the estimation of speeds and ranges, and the application of leads for fire against mechanized targets, that they can perform the duties of gun pointers under the stress of antimechanized action.

c. Caliber .50 AA machine guns.—(1) Fire should not be opened at ranges greater than 400 yards.

(2) At such ranges, the maximum ordinate of the trajectory is less than 3 feet. As a result a flat correction for superelevation (ϕ_s) may be applied and the sights themselves will supply the correct angle of site. Before opening fire, a vertical deflection of plus 3 mils should be set on the sights. The target should be tracked for elevations on the line of the top track housing.

(3) Lateral leads are best estimated in terms of target lengths that is, the over-all length of the silhouette as seen by the gunner, and are measured from the leading edge of the target. The gun should be swung across the target and the swing continued until the proper number of target lengths lead has been taken. Fire is then opened and adjustment made by individual tracer control.

(4) The following tables showing the proper aiming point on the target or the correct lateral lead in target lengths to hit the center of the target are presented as an aid for training. It is not expected that these tables will be used during actual fire because gun pointers should be so thoroughly drilled in their use that the application of correct leads becomes a matter of second nature. Leads are always meas-

ured from the leading edge of the target. See paragraph 92 for a method of calculating the lateral leads.

LATERAL LEADS IN TARGET LENGTHS

Caliber .50 M1 ammunition (MV 2,700 f/s)

Target speed, 15 miles per hour

Target crossing perpendicular to line of site:

Range in yards	Target length		
	4 yards	6 yards	8 yards
100	Forward edge	Center	Center.
200	do	Forward edge	Forward edge.
300	$\frac{1}{4}$	do	Do.
400	$\frac{1}{2}$	$\frac{1}{4}$	Do.

Target crossing at 45° to line of site:

Range in yards	Target length		
	4 yards	6 yards	8 yards
100	Center	Center	Center.
200	Forward edge	do	Do.
300	do	Forward edge	Forward edge.
400	$\frac{1}{4}$	do	Do.

Target speed, 30 miles per hour

Target crossing perpendicular to line of site:

Range in yards	Target length		
	4 yards	6 yards	8 yards
100	Forward edge	Forward edge	Forward edge.
200	$\frac{1}{2}$	$\frac{1}{4}$	Do.
300	1	$\frac{1}{2}$	$\frac{1}{4}$.
400	$1\frac{1}{2}$	$\frac{3}{4}$	$\frac{1}{2}$.

Target crossing at 45° to line of site:

Range in yards	Target length		
	4 yards	6 yards	8 yards
100	Forward edge	Center	Center.
200	$\frac{1}{4}$	Forward edge	Forward edge.
300	$\frac{1}{2}$	$\frac{1}{4}$	Do.
400	$\frac{3}{4}$	$\frac{1}{4}$	$\frac{1}{4}$.

d. 37-mm and 40-mm guns.—(1) Fire should not be opened at ranges greater than 600 yards.

(2) At these ranges, as in the case of the machine guns, the trajectory of even the M59 projectile (MV 2,050 f/s) is

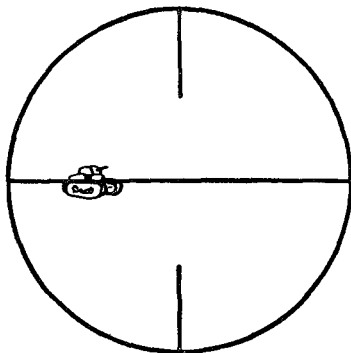

FIGURE 69.—Correct pointing for range with M7 telescope. Horizontal cross-hair on top track housing.

sufficiently flat to permit the use of a single correction for superelevation (ϕ_s) for all ranges. Superelevation of +6 mils should be applied and the horizontal cross-hair of the vertical sight carried on the top track housing of the tank as shown in figure 69.

(3) Lateral leads are estimated and applied by the gun pointer as shown in figure 70. The following tables, similar

to those described in paragraph c(4) above for the caliber .50 machine guns, are presented as an aid for training:

LATERAL LEADS IN TARGET LENGTHS

37-mm M59 ammunition (MV 2,050 f/s)

Target speed, 15 miles per hour

Target crossing perpendicular to line of site:

Range in yards	Target length		
	4 yards	6 yards	8 yards
100.....	Forward edge.....	Center.....	Center.
200.....	do.....	Forward edge.....	Forward edge.
300.....	$\frac{1}{2}$	do.....	Do.
400.....	$\frac{3}{4}$	$\frac{1}{4}$	$\frac{1}{4}$.
500.....	1.....	$\frac{1}{2}$	$\frac{1}{4}$.
600.....	$1\frac{1}{2}$	$\frac{3}{4}$	$\frac{1}{2}$.

Target crossing at 45° to line of site:

Range in yards	Target length		
	4 yards	6 yards	8 yards
100.....	Center.....	Center.....	Center.
200.....	Forward edge.....	Forward edge.....	Do.
300.....	do.....	do.....	Forward edge.
400.....	$\frac{1}{4}$	do.....	Do.
500.....	$\frac{1}{2}$	$\frac{1}{4}$	Do.
600.....	$\frac{3}{4}$	$\frac{1}{4}$	$\frac{1}{4}$.

Target speed, 30 miles per hour

Target crossing perpendicular to line of site:

Range in yards	Target length		
	4 yards	6 yards	8 yards
100.....	Forward edge.....	Forward edge.....	Forward edge.
200.....	$\frac{3}{4}$	$\frac{1}{4}$	Do.
300.....	$1\frac{1}{2}$	$\frac{3}{4}$	$\frac{1}{2}$.
400.....	2.....	$1\frac{1}{4}$	$\frac{3}{4}$.
500.....	$2\frac{1}{2}$	$1\frac{1}{2}$	1.
600.....	$3\frac{1}{4}$	2.....	$1\frac{1}{2}$.

Target crossing at 45° to line of site:

Range in yards	Target length		
	4 yards	6 yards	8 yards
100.....	Forward edge.....	Forward edge.....	Center.
200.....	$\frac{1}{4}$	do.....	Forward edge.
300.....	$\frac{3}{4}$	$\frac{1}{4}$	Do.
400.....	$1\frac{1}{4}$	$\frac{3}{4}$	$\frac{1}{4}$.
500.....	$1\frac{1}{2}$	1.....	$\frac{1}{2}$.
600.....	2.....	$1\frac{1}{4}$	$\frac{3}{4}$.

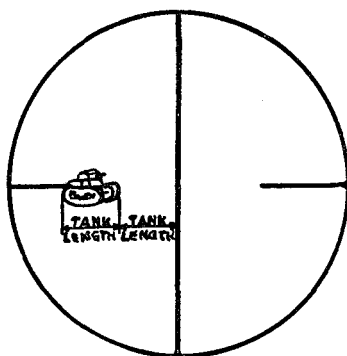

FIGURE 70.—Correct lateral lead with M7 telescope. Lead measured from leading edge of target.

(4) Fire will be adjusted by tracer control. Since dust from the muzzle blast may obscure the target and interfere with rapid adjustment of fire, all possible steps should be taken to prevent this interference.

■ 86. PRINCIPLES OF ANTITANK FIRING.—*a.* It is essential that fire be held until targets are within the ranges discussed previously for each weapon. Opening fire must be accurate, for it is probable that once an anti-aircraft artillery position has been disclosed, no movement to alternate positions can be made during that phase of the battle. The shorter the range at which fire is opened the greater is the probability of obtaining hits with the opening rounds.

b. Fire will be opened as prescribed by the platoon or fire-unit commander for 37-mm and 40-mm guns. In general, as many targets as possible within range will be engaged by the guns of a fire unit. The fire of more than one gun on one target will be ordered only when no other suitable target presents itself for the second gun.

c. The crews of moving tanks are relatively deaf, and blind except in a narrow sector to their front. These handicaps should be exploited by the use of ambush wherever possible. For example, three tanks which appear to be traveling a course that will take them to the flank of a gun position should be permitted to come almost abreast of the position and the last tank in the column engaged first, then the second in column; and, last, the first in column,

d. On the other hand, when tanks approach and threaten a gun position, the tank which is most menacing (usually the closest to the gun) should be fired upon until hit; then the next nearest (or most menacing) should be fired upon. It must be noted, however, that the most effective fire from tank guns is obtained when firing from a halted tank. Consequently, a halted tank that is firing upon the gun position may be more menacing than a closer, moving tank.

e. When a tank has been stopped, one more round should be fired into it before another target is engaged. However, no effort should be made completely to destroy disabled tanks as long as a mobile tank is within range or view, unless the disabled tank is firing upon friendly troops.

SECTION III

ASSAULT OF FORTIFICATIONS

■ 87. GENERAL.—The targets which the antiaircraft artillery automatic weapons may be required to engage are the ports and embrasures of fortifications.

■ 88. TECHNIQUE.—*a.* In the assault of a permanent fortification, the mission of the antiaircraft artillery is to require the defenders to keep ports closed and deny their use for returning fire. This mission can be effectively accomplished by 37-mm and 40-mm guns firing HE shell with supersensi-

tive fuze. Where the actual destruction of smaller works is required, direct fire by 3-inch and 90-mm guns firing armor-piercing shot will probably be required. In either case the problem involves direct laying on a stationary target, and the comments made in paragraph 85 are appropriate for this mission.

b. In order that opening rounds will fall near the target, ranges should be determined as accurately as possible and translated into vertical deflections and applied to the M7 sights of the automatic weapons. Since the effects of wind and drift are usually negligible at short ranges, no lateral corrections are indicated for opening fire. Adjustment of fire will be as described in paragraph 85.

SECTION IV

ENGAGEMENT OF WATER-BORNE TARGETS

■ 89. GENERAL.—*a.* The employment of antiaircraft artillery automatic weapons against water-borne targets may be necessary due to the need for weapons with relatively high muzzle velocity and high rate of fire which can be used against high speed maneuvering, small water-borne targets. The fact that our present antiaircraft matériel was not designed for and is not basically suited for use against water-borne targets must be borne in mind before a decision is reached to employ these weapons on such missions.

b. (1) In approaching the problem of employment of anti-aircraft artillery automatic weapons against water-borne targets, it is necessary to consider the probable enemy target and tactics. Due to the comparative newness of the motor torpedo boat and the lack of information as to its employment, many assumptions will have to be made.

(2) It is visualized that motor torpedo boats will operate in groups of about five. They will depend on their speed and maneuverability for protection against fire from shore batteries. They will attempt an attack at high speed in order to take advantage of the element of surprise.

(3) Motor torpedo boats have the following characteristics:

(a) Length, from 55 to 100 feet.

(b) Width, from 13 to 20 feet.

- (c) Speed, from 30 to 60 miles per hour.
- (d) Radius of action, up to 1,000 miles at reduced speed.
- (e) Hull construction, almost entirely of wood.
- (f) Low silhouette, about 10 feet above water line.

■ 90. AVAILABLE ANTI-AIRCRAFT ARTILLERY WEAPONS.—*a.* The weapons to be considered for use against water-borne targets are the 37-mm and 40-mm automatic systems, with their standard and emergency fire-control systems.

b. In general, the 3-inch or 90-mm antiaircraft guns should be used for defense against motor torpedo boats. Although, in some cases, the 37-mm and 40-mm guns may have sufficient range capabilities for the purpose, their caliber is too small to insure sufficient damage from one hit. The larger caliber guns will permit firing at greater ranges, thus increasing the time that the targets can be taken under fire, and will also insure destructive effect from one hit. In addition, ricochet bursts from the larger caliber guns may cause considerable damage.

c. In general, two-gun fire units should be used. This is the standard unit for the 37-mm gun with central tracer control. The 37-mm and 40-mm guns with director control will have to fire as individual guns. Thus, they may engage either one or two targets simultaneously.

■ 91. 37-MM AND 40-MM MATÉRIEL.—*a. General.*—In general, effective fire from the 37-mm and 40-mm automatic cannon against motor torpedo boats can be obtained only by accurate adjustment of fire. This adjustment is facilitated if the rate of fire is held to about 60 shots per gun per minute, using single shot operation instead of automatic fire. This condition is believed to be true of each of the methods of fire control discussed below.

b. 37-mm gun with control equipment set M1.—In this case a two-gun fire unit sited as low as feasible is used. It will be found advantageous to site the control station above and in rear of the guns in order to make the determination of overs and shorts easier. Initial lateral and vertical leads must be estimated. These leads are altered by the control station operators, based on their observation of the lateral and vertical deviations of the splashes from the target. Fire

will be relatively ineffective beyond a range of 2,500 yards because of the difficulty of sensing splashes correctly.

c. *37-mm and 40-mm guns with directors of Kerrison type (M5 or M6).*—The effective use of these directors requires that the gun and director be sited as low as feasible. Fire should not be opened beyond 2,000 yards' range because of mechanical limitations of these directors. The range setter should estimate and set into the director a slant range toward which the target's course is tending and hold this value until it is evident that either a hit is obtained or the slant range set is obviously too long or too short. The slant range should be corrected then in bold steps of about 500 yards in the indicated direction. It will be found that, because of the height of the director, the range setter will rarely have an unobstructed view of the target and must depend, in order to adjust slant range, on the sensings of the overs and shorts repeated to him by the trackers. Sensings of overs and shorts are comparatively easy for the trackers since, in general, the splash of a short will eclipse the target and the splash of an over will silhouette it.

d. *37-mm and 40-mm guns using gun sights.*—The same method is employed using gun sights as is used with the control equipment set M1. However, both vertical and lateral initial leads will be estimated and applied by the gun pointers and adjusted in accordance with their observation of the fall of shots. Generally, this method will be less effective than either director or central tracer control and should be resorted to only in the event that director control cannot be used.

SECTION V

LATERAL LEADS AND LEAD CHARTS

■ 92. LATERAL LEADS.—a. When a mechanized target is moving perpendicular to the line of site, the value of the lateral lead depends upon the travel of the target during the time of flight of the projectile. The time of flight of a caliber .50 M1 projectile for a range of 100 yards is given on page 8 of FT 0.50-AA-E-4 as 0.14 second. During this 0.14 second, a mechanized target traveling at a speed of 15 miles per

hour will move 0.14 second times 7.5 yards per second or 1.05 yards. If the forward edge of a 4-yard mechanized target were used as the aiming point, the projectiles would hit the target about 1 yard from the front. The center of the target would be used as the aiming point if the targets were

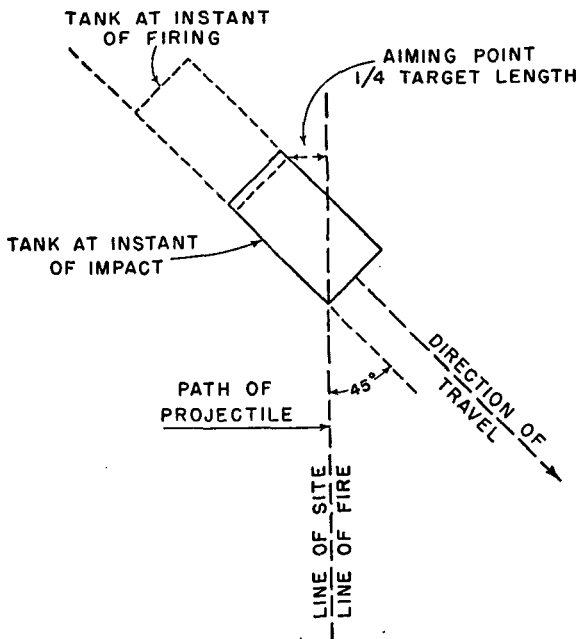

FIGURE 71.—Target crossing at 45° to line of site.

6 or 8 yards long. Similar calculations may be made for 200, 300, and 400 yards' range and the location of the aiming point with respect to the target determined.

b. When a mechanized target is crossing at 45° to the line of site, the value of the lateral lead depends upon the lateral component of the travel of the target during the time of flight of the projectile. In this case, the target length

is the over-all length of the silhouette as seen by the gunner. The time of flight of a caliber .50 M1 projectile for a range of 400 yards is 0.51 second. During this 0.51 second, a mechanized target traveling at a speed of 15 miles per hour will move 0.51 seconds times 7.5 yards per second or 3.82 yards. If a lateral lead of $\frac{1}{4}$ target length were taken on the leading edge of the silhouette of tank as shown in figure 71, the path of the projectile would be approximately through the center of the target.

■ 93. LEAD CHARTS.—*a. Use.*—A knowledge of the construction of lead charts, length and height of targets in terms of mils, and the conversion of lead chart leads into leads in terms of target lengths for horizontal fire will be of value for the determination of the correct lateral and vertical leads in terms of target lengths for any course and speed of the target.

b. Basic assumptions.—The computation of lateral and vertical leads for horizontal fire is a simple process of solving right triangles and taking certain data out of firing tables. Certain assumptions are made that are not exactly correct, but which are so nearly correct that no error of any magnitude is introduced into the results by their acceptance. Such errors are within the probable error of the guns.

(1) It is assumed that initial lateral lead will increase in direct proportion to the increase in target speed up to 50 miles per hour.

(2) It is assumed that vertical lead is exactly equal to superelevation for the horizontal range to the target, and that it is not affected by speed.

(3) It is assumed that leads will be the same on both the approaching and the receding leg of a crossing target.

c. Computation form.—The following form has been devised for use in computing leads for horizontal fire. One such form will be required to figure the lateral and vertical leads for one target, for one speed, and for one range to mid-point (R_m). The form itself is self-explanatory, as is the method of making the computations with the Crichlow slide rule.

CALCULATION OF LEADS FOR HORIZONTAL FIRE

[Position data: $R_m = 600$ yards; $S_f = 10$ yards/seconds; $FT = 37\text{-AA-N-2}$; Gun = 37-mm; $MV = 2,600$ feet/seconds]

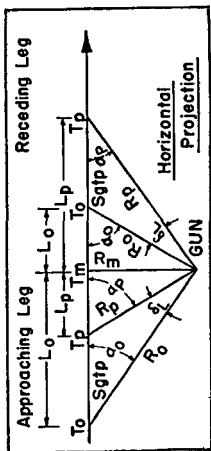

Solution by Orichlow slide rule										
Set L at	Set S at	Turn both until S is at	Read under L on							
Assumed or selected				600	400	200	0	200	400	600
1 L_p	R_m or L_p (larger) Scale E	R_m or L_p (smaller) Scale E	Index Scale C 1	1,000	1,000	1,273	1,600	1,273	1,000	800
2 $\alpha_p = \tan^{-1} \frac{R_m}{L_p}$	R_m Scale E	Index Scale E	Line 2 Scale D	722	722	632	600	632	722	848
3 $R_p = \frac{R_m}{\sin \alpha_p}$			Scale E							

4 t_p	From firing tables using R_p			1.18	0.98	0.85	0.80	0.85	0.98	1.18
5 S_{t_p}	S_t Scale E	Index Scale E	Line 4 Scale E	12	10	9	8	9	10	12
6 $L_o = L_p \pm S_{t_p}$	+ on approaching leg - on receding leg			612	410	209	8	191	390	588
7 $\alpha_o = \tan^{-1} \frac{R_m}{L_o}$	R_m or L_o (larger) Scale E	R_m or L_o (smaller) Scale E	Index Scale E	790	989	1,260	1,586	1,286	1,012	810
8 $\delta L =$	$\alpha_p - \alpha_o$ on approaching leg $\alpha_o - \alpha_p$ on receding leg			10	11	13	14	13	12	10
9 $\sigma L =$	ϕ_o —From firing tables using R_p			11	9	8	8	8	9	11

¹ If numerator is less than denominator, the angle is less than 800 mils.

■ 94. CONSTRUCTION OF LEAD CHARTS.—One very useful way to construct lead charts is to plot and draw isolead curves of the computed lead values. One chart will be constructed for lateral and another for vertical leads. Vertical and lateral leads are computed for one speed of target. Figures 72 and

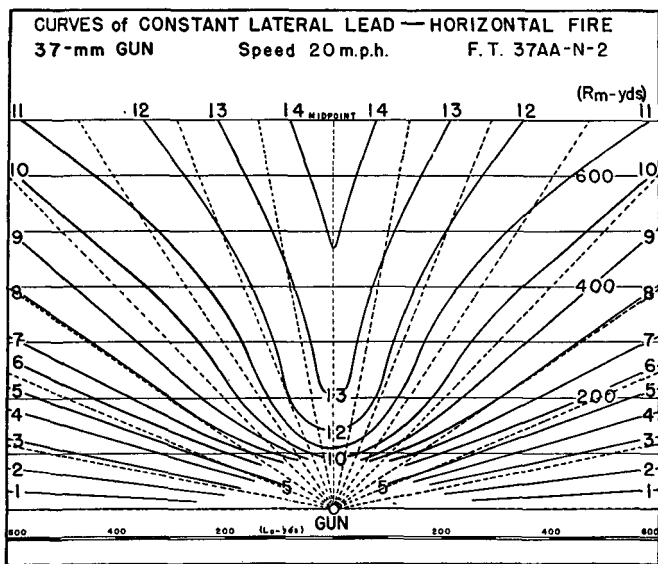

FIGURE 72.—Lateral lead chart, horizontal fire.

73 illustrate lateral and vertical leads for a 20 mph target. These leads are computed for all values of R_m from 0 to 600 yards in 100-yard increments. A convenient scale is selected for L_o and R_m , and the lines of R_m (representing the courses of the target) are drawn.

a. Lateral lead chart (fig. 72).—(1) Plot the even mil values of lateral lead against L_o values along each R_m line on both sides of the midpoint.

(2) Connect all points of the same lead value by a continuous line, smoothing out the curves.

b. *Vertical lead chart* (fig. 73).—(1) On the $R_m=0$ line, the even mil values of superelevation are plotted against their proper firing table range away from the position *gun*.

(2) Using the point *gun* as center, draw concentric semi-circles from these even mil superelevation points. (These

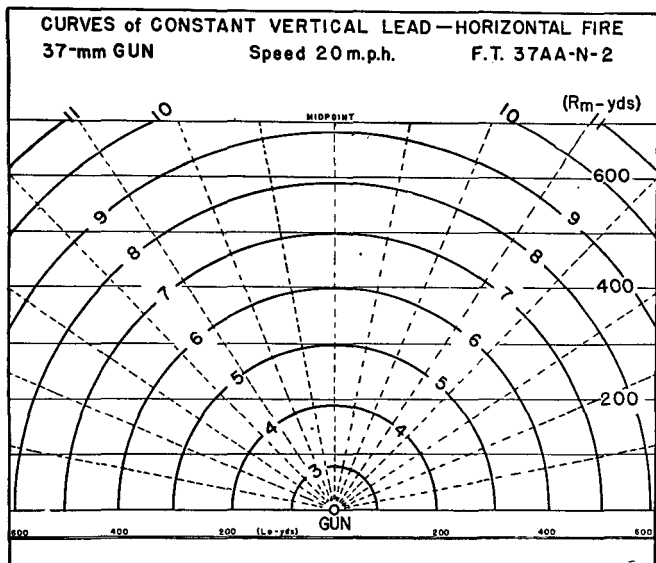

FIGURE 73.—Vertical lead chart, horizontal fire.

superelevation isolead curves are now known as vertical lead curves.)

c. With the point *gun* as the center, draw mil ray lines on each chart for each 200 mils.

d. Construct a scale of the chart along the bottom.

e. Label each chart with all data pertinent to that chart.

■ 95. LEADS IN TARGET LENGTHS.—a. *General*.—Tables can now be made up to show the mil values of the length and height of various targets at various ranges and at various angles to the observer. Figure 74① and ② shows such a form.

HEAVY TANK		
Approximate Dimensions: 9 Yds. long, 3 Yds. wide, 4 Yds. high.		
Dimensions (mils) at 1000 Yds. Range.		
Crossing at Right Angles	Crossing at 45°	Coming
9 mils wide 4 mils high	9 mils wide 4 mils high	4 mils high
Dimensions (mils) at 500 Yds. Range.		
Crossing at Right Angles	Crossing at 45°	Coming
18 mils wide 8 mils high	17 mils wide 8 mils high	8 mils high
MEDIUM TANK		
Approximate Dimensions: 5-6 Yds. long, 2.5 Yds. wide, 2.5 Yds. high.		
Dimensions (mils) at 1000 Yds. Range.		
Crossing at right angles	Crossing at 45°	Coming
6 mils wide .3 mils high	6 mils wide 3 mils high	3 mils high
Dimensions (mil) at 600 Yds. Range.		
Crossing at right angles	Crossing at 45°	Coming
10 mils wide 4 mils high	10 mils wide 4 mils high	4 mils high
Dimensions (mils) at 300 Yds. Range.		
Crossing at right angles	Crossing at 45°	Coming
20 mils wide 8 mils high	20 mils wide 8 mils high	8 mils high

① Lengths and heights of heavy and medium tanks in terms of mils.

FIGURE 74.

LIGHT TANK		
Approximate Dimensions 3-5 Yds. long, 2 Yds. wide, 2 Yds. high.		
Dimensions (mils) at 600 Yds. Range.		
Crossing at right angles	Crossing at 45°	Coming
5-8 mils wide 3 mils high	6-8 mils wide 3 mils high	3 mils high
Dimensions (mils) at 300 Yds. Range.		
Crossing at right angles	Crossing at 45°	Coming
10-16 mils wide 6 mils high	12-16 mils wide 6 mils high	6 mils high
ARMORED CAR		
Approximate Dimensions 3-6 Yds. long, 2-3 Yds. wide, 2-3 Yds. high		
Dimensions (mils) at 600 Yds. Range.		
Crossing at right angles	Crossing at 45°	Coming
5-10 mils wide 3-5 mils high	6-11 mils wide 3-5 mils high	3-5 mils high
Dimensions (mils) at 300 Yds. Range.		
Crossing at right angles	Crossing at 45°	Coming
10-20 mils wide 6-10 mils high	12-22 mils wide 6-10 mils high	6-10 mils high
LANDING BOAT		
Dimensions (mils) at 600 Yds. Range.		
Crossing at right angles	Crossing at 45°	Coming
22 mils wide 3 mils high	20 mils wide 3 mils high	3 mils high

② Lengths and heights of light tanks, armored cars, and landing boats in terms of mils.

FIGURE 74.—Continued.

37-mm Gun		
MEDIUM TANK	Range 600 Yds.	Speed 20 m.p.h.
Crossing at right angles	Crossing at 45°	Coming
$S_L = 14$ mils = 1 1/2 target lengths.	$S_L = 10$ mils = 1 target length.	X
$\sigma_L = 8$ mils = 2 target heights.		
MEDIUM TANK	Range 300 Yds.	Speed 20 m.p.h.
Crossing at right angles	Crossing at 45°	Coming
$S_L = 13$ mils = 2/3 target lengths.	$S_L = 10$ mils = 1/2 target lengths.	X
$\sigma_L = 5$ mils = 1/2 target height.		

③ Conversion of leads into terms of target length.

FIGURE 74.—Continued.

b. Conversion of lead chart leads into leads in terms of target lengths.—When the trackers on the gun track and set off leads for a particular target through their sights, and there is no method of setting off mil lead values, it is desirable to lead the target in terms of target lengths and heights. To determine the target length and height on which to open fire the following method is used:

(1) With the R_m , the speed of the target, and the angle (mil ray line) it makes with the *gun* and midpoint known, read the lateral and vertical leads from the lead charts.

(2) Knowing the length and height of the target, determine the mil value of the target's length and height.

(3) Divide the lateral and vertical leads by the length and height (in mils) of target, and this will give the lateral and vertical leads of the target in terms of target lengths and heights.

(4) Figure 74③ is an example of how such leads can be tabulated into forms which show the length and height leads for various targets at various ranges, speeds, and angles of approach. The lateral and vertical trackers can either use these tabulated forms to determine the leads with which to open fire, or they can memorize enough of the values to know the leads with which to open fire.

CHAPTER 7

OBSERVATION AND ADJUSTMENT OF FIRE

	Paragraphs
SECTION I. Methods of observation-----	96-99
II. Individual tracer control-----	100-101
III. Central tracer control-----	102-106
IV. Fire adjustment-----	107-109
V. Data transmission-----	110-113

SECTION I

METHODS OF OBSERVATION

¶ 96. GENERAL.—When automatic weapons are fired at ground or water-borne targets during daylight, the fall of shots usually can be readily observed and a correction applied to place the cone of fire on the target. However, when firing at aerial targets, using ball ammunition alone, the position of the cone of fire with respect to the target cannot be determined. Similarly, if firing tracerless, high-explosive projectiles, the position of the cone of fire with respect to the target would only be disclosed when a direct hit caused a projectile to burst. The difficulty has been partially solved by using tracer ammunition to disclose the cone of fire to the observer. All 20-mm, 37-mm, and 40-mm anti-aircraft gun ammunition contains a tracer element, and machine gun ammunition is loaded in belts with every fifth round a tracer. Although this use of tracer ammunition permits the observer to see the trace of the fired rounds, the position of the cone of fire with respect to the target is still difficult to determine. Two general methods of observing tracers have been developed, single-station observation and bilateral observation. Each of these methods recognizes two basic facts: first, that when shots actually are passing through the target, an observer, regardless of his position, will always see the trajectory as passing through the target; and, second, that from a particular position the trajectory may appear to pass through the target when actually it is some distance from the target.

■ 97. SINGLE-STATION OBSERVATION.—*a.* The first method of tracer observation attempted was single-station observation, the simplest form of which is observation of tracers by the gunner himself.

b. In this method of observation, the observer must first select the point on the trajectory which is at or near the same slant range as that to the target, and then note how far the instantaneous cone of fire at this point must be shifted to aline it with the target. The first operation is by far the more difficult of the two. Referring to figure 75, if he selects a point at a shorter range than that to the target, such as point *b*, and alines this point with the target (line gun-*B*), his tracer stream will actually be behind the target. Similarly, if he selects a point at a greater range than that to the target, such as point *c*, and alines this point with the target (line gun-*C*), the tracer stream will be in front of the target. It is only when the point on the trajectory which he selects is at the same or very near the same range as the target (as point *a*) that the tracers will pass through the target.

c. In determining the proper point on the trajectory to aline with the target, the observer is dependent on depth perception. In exercising this ability, he is taking advantage of several phenomena of sight which have become known to him largely through experience. Three factors are: the apparent size of the target, the amount of detail of the target which can be seen, and the relative apparent size and brilliance of the tracers at various ranges. At slant ranges beyond 600 yards, depth perception as a means of selecting the proper point on the trajectory becomes relatively ineffective.

d. Because of the limitations of depth perception as a means of selecting the point on the trajectory which is to be alined with the target, the following practical rules may be applied with good results: When firing at an actual plane, part of the tracer stream may be observed silhouetted against the plane. In this case the tracers are actually behind the target. If, on the other hand, a portion of the tracer stream appears to be eclipsed by the plane, the tracers are really passing in front of the target.

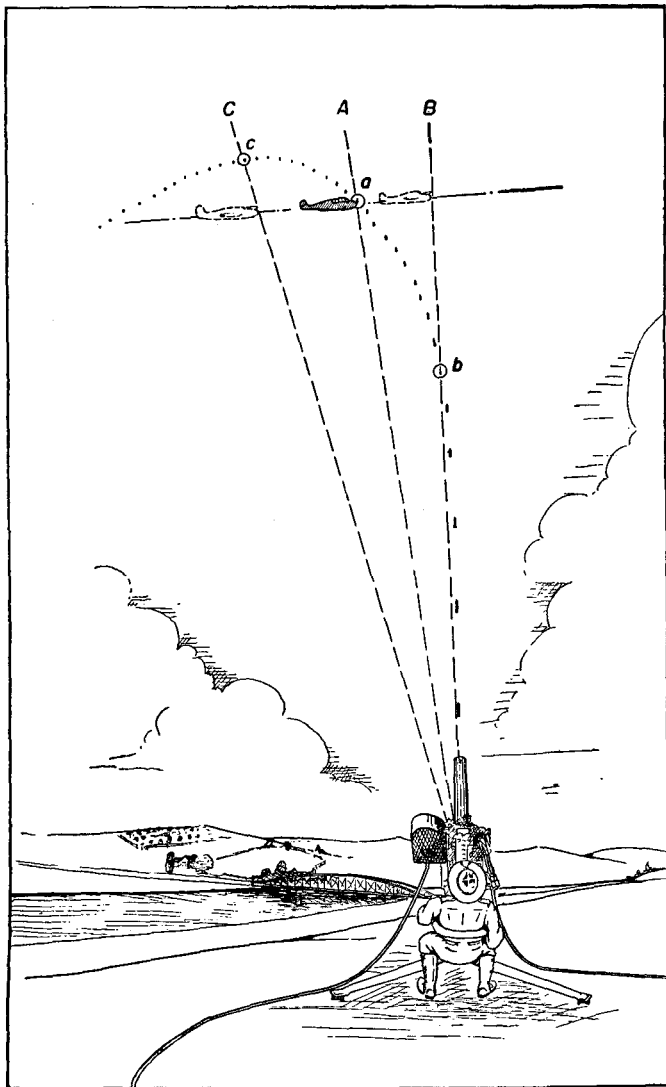

FIGURE 75.—Single-station observation.

■ 98. BILATERAL OBSERVATION.—*a.* The short, effective range and unreliable results of single-station observation necessitated a further study of possible methods of tracer observation. This investigation showed that for best results two spotters were required, each in a fairly definite position with relation to the gun-target line, one to observe lateral deviation

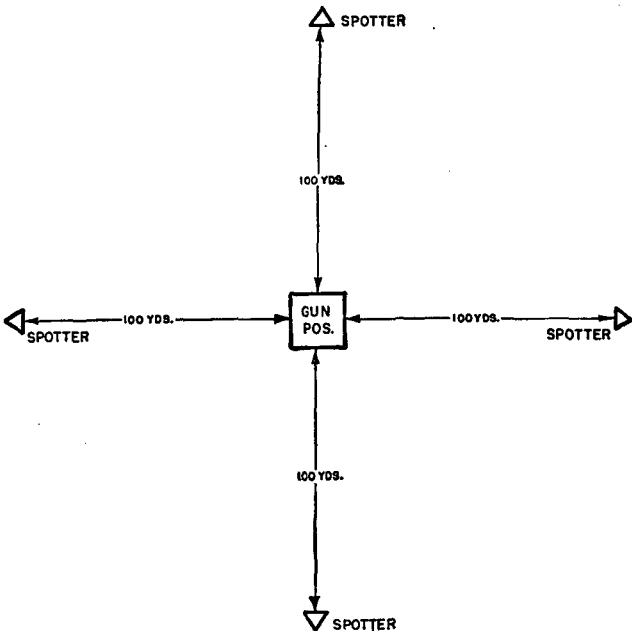

FIGURE 76.—Location of spotters for caliber .30 machine gun firing. tions of the tracer stream from the target and the other to observe vertical deviations. This method is now the standard method of spotting for central tracer control.

b. In bilateral observation, depth perception is not employed by the spotters. The method of observation is somewhat like bilateral spotting as used in the adjustment of fire for antiaircraft guns. Each of the two observers notes the position of the tracer stream with relation to his observer-

target line. If both observers see the tracer stream alined with the target at the same instant, the tracer stream is passing through the target. Best observation is obtained when the lateral observer is in front of the gun (between the gun and the horizontal projection of the target's course) and the vertical observer is on the flank from which the target is coming (see fig. 76). Distances from the guns are the same for both lateral and vertical observers, about 100 yards and 150 yards for caliber .30 and caliber .50 machine guns, respectively, and about 200 yards for 37-mm and 40-mm guns when using sight control. These distances are only approximate. Experience has shown that observers at greater distances cannot see tracers readily at all points in the field of fire, and that observers at shorter distances are handicapped in their observation by a small observing angle.

c. For a normal target practice set-up, one observer is sufficient to observe lateral deviations, but two observers are necessary to observe vertical deviations if courses are flown in both directions. For coming courses, the lateral observer should be directly under the course of the target, while either of the flank observers observes vertical deviations. For service conditions, four observers (spotters) are placed around the fire unit 90° apart and at distances from the gun position depending on the type of gun (see fig. 76). As soon as the approximate target course is known, the appropriate spotters are selected and proper telephone connections made to the adjusters.

■ 99. DIFFICULTIES IN OBSERVATION OF FIRE.—*a.* In both single-station observation and bilateral observation, the difficulty of observation is increased by the optical illusion of a pronounced curve in the trajectory (see fig. 77) caused by observing, simultaneously, tracers fired at successive azimuths, and by the movement of the airplane with respect to each tracer as it travels along the trajectory. *This illusion can be partially eliminated if the observer centers his attention on the part of the trajectory in the vicinity of the target.*

b. When single-station observation is by a gunner or gun pointer, the difficulty of observation is increased, except at

short ranges, by the relative brightness of tracers near the gun, and by some smoke and flash from the muzzle.

c. During daylight the use of red glasses or filters cuts out some of the excess light and yet allows the observer to see the red tracer distinctly. Glasses with red lenses are issued for use in the observation of tracers.

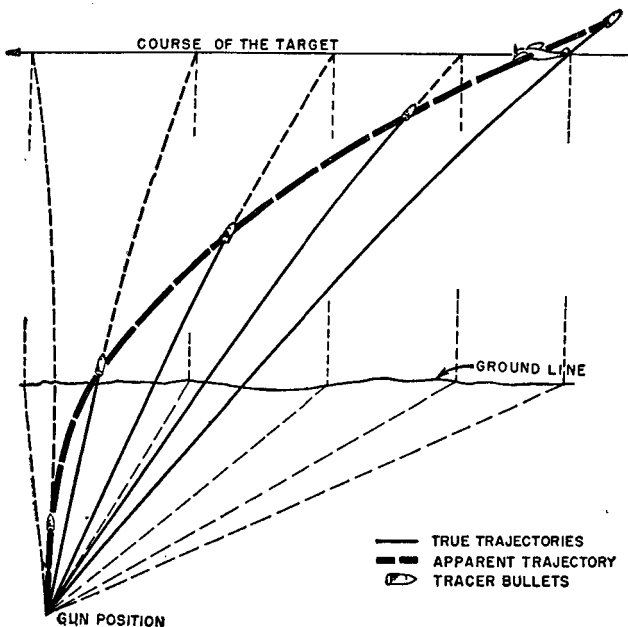

FIGURE 77.—Apparent tracer trajectory.

d. In bilateral observation, both observers must see the trajectory as passing through the target for fire to be adjusted onto the target. To keep the trajectory passing through the target, the observers constantly report its position so that fire can be adjusted. If either observer allows the trajectory to shift from the target, the other observer's observations will be in error. This error will be kept to a minimum if adjustments of fire are made smoothly, thus preventing the shifting of fire back and forth across the target.

SECTION II

INDIVIDUAL TRACER CONTROL

■ 100. GENERAL.—*a.* Individual tracer control is a method of fire control in which each gunner or gun pointer observes the tracer trajectory of his own gun and makes the necessary corrections in pointing to place the fire of his gun on the target and keep it there. The method of observation is single-station observation. The application of individual tracer control to the 37-mm or 40-mm gun has not proved satisfactory except as an emergency method of fire control.

b. In individual tracer control each gun functions as a separate firing element. The gunner (or gun pointers) must estimate the required initial leads, fire the gun, observe tracers, and adjust fire. All of these operations must be performed within the space of a few seconds. It is obvious that only by the most careful selection of personnel and extensive training can satisfactory results be attained. Gunners must be thoroughly familiar with lead characteristics as well as with the proper handling of the gun and mount. They must be able to estimate within fairly close limits the speed of targets, slant ranges, and the probable direction of course of the targets, and they must also be able to convert these estimates into required leads and rates of change of leads.

c. The principal advantage of individual tracer control is that it requires no data transmission and can therefore be placed in operation against surprise targets with almost no loss of time. This method of fire control may be employed where no director or central control equipment is provided, or in mobile situations when time does not permit the use of the director.

■ 101. SELECTION OF GUNNERS.—*a.* The many duties which the gunners are required to perform simultaneously make it necessary to select personnel who are exceptionally quick-thinking and well-coordinated. They must also have sufficient physical agility to manipulate capably the gun and mount. They must be steady under gunfire and their eyes must be only moderately affected by the smoke and flash of firing.

b. In order that individual tracer control may be an effective method of fire control, the gunner must thoroughly understand these important facts of correct tracer observation:

(1) He must develop an ability to determine whether the tracers are passing high or low or right or left of the target. He must not permit his eyes to follow the path of the tracers from the gun, but should focus his eyes on the target and should learn to bring the stream of tracers to it.

(2) If the gunner concentrates his attention on the target, he will see only that part of the tracer trajectory which is near the target, and can estimate his error in pointing according to these rules:

(a) If no part of tracer stream is up to the target laterally, the gun is firing behind the target.

(b) If no part of tracer stream rises as high as target vertically, on a constant altitude course, the gun is firing low.

(c) If the tracer stream appears to be silhouetted against the target, the gunner is firing behind the target.

(d) If the tracer stream appears to be eclipsed by the target, the trajectory is actually in front of target.

(3) The gunner must always keep in mind the time lag in adjusting fire by tracer observation. The time of flight of the projectile, and hence the time required for an adjustment of fire to take effect, may seem to be long. Nevertheless, the gunner must keep his eyes on the part of the tracer stream near the target, and wait for fire adjustment to take effect.

(4) Correct tracer observation is an ability developed only by constant practice on moving targets. Gunners and gun pointers should seize every opportunity to fire, and should make it a habit to observe the firing of others, noting carefully the direction in which shots are missing.

c. The following hints for use in firing with individual tracer control will be found profitable:

(1) Use a sight for the initial lead. A well-trained gunner usually opens fire with a fairly accurate lateral lead, but is apt to find his opening burst off badly on vertical lead.

(2) Make the initial lead exactly correct, if you can, or too much. It is much easier to allow the tracer stream to drop back on target than to attempt to catch up on target after the opening of fire.

(3) The gunner must realize the vital importance of an accurate initial lead. The target will be in the effective range of the weapon for only 5 or 6 seconds. It is very probable that not more than one adjustment of fire from tracer observation may be made; therefore, the opening burst should be close to the target.

(4) After fire is opened, no attempt should be made to use the sight; both eyes should be concentrated on the target and on that part of tracer stream near it. In this way, rapid adjustment may be made as indicated above.

(5) The gunner should keep the gun moving in the direction of the required lead in much the same manner as that of a good wing shot, when shooting at a moving bird. If the tracers appear ahead of the target, decrease rate of swing momentarily, then increase to normal. If tracers are behind target, make a bold increase in lead, then take up the normal rate.

(6) Individual tracer control can be effective only when—

(a) The tracers are plainly visible. *Use red spotting glasses.*

(b) Target is within effective range. *Hold your fire.*

(c) Your gun is firing smoothly and continuously. *Prevent stoppages.*

(d) The tracer stream is continuous. *Use high rate of fire and plenty of tracers.*

(e) Your pointing is *steady and accurate.*

SECTION III

CENTRAL TRACER CONTROL

■ 102. GENERAL.—Central tracer control is a method of fire control in which the sights of all guns of the fire unit are controlled from a central point, adjustment of fire being accomplished by the application of corrections at this central point based on tracer observation. The gunners' only duty in connection with pointing is to keep their gun sights alined with the target.

■ 103. EQUIPMENT.—*a.* The present standard equipment for central tracer control is the automatic gun, antiaircraft,

control equipment set M1. This set can be used either with the M2 anti-aircraft machine-gun mount or with the 37-mm anti-aircraft gun carriage M3. It consists of a control box for setting leads, and several flexible shafts for transmission of these leads to the gun sights.

b. The control box consists of two separate mechanisms, one for lateral and the other for vertical sight control. Each mechanism consists of one input flexible shaft coupling, four output flexible shaft couplings (four used for machine guns, two used for 37-mm guns), an adjusting dial with knob, and a lead dial (having a scale, a lead index, and a transmitted lead index) with dual handwheel drive. Provisions have been made in the design of the control box for utilizing a computer which would be connected to the input couplings but such computers have not been authorized or constructed. The operator of the lead handwheel matches the transmitted lead index with the lead index, thereby rotating the flexible shafts, positioning the gun sights.

■ 104. STANDARD SYSTEM.—*a.* In the standard system of central tracer control, bilateral observation of tracers is employed. Spotters, located as described in paragraph 98*c*, and adjusters, at the control box, all observe the tracer trajectories of all guns simultaneously. Each adjuster, aided by reports by telephone from the corresponding spotter, continuously applies the necessary leads to keep the cone of fire on the target. One adjuster-spotter team makes the necessary lateral adjustment and another adjuster-spotter team makes the necessary vertical adjustment.

b. Past experience and records are the only means of evaluating the effectiveness of this method. These show that a satisfactory percentage of hits can be obtained with the caliber .50 anti-aircraft machine gun at ranges not exceeding 1,200 yards.

c. The selection of adjusters for this method of firing must be done in about the same manner as in the selection of individual tracer control gunners. However, the adjusters must have a more thorough knowledge of lead characteristics, and less consideration need be given to their physical agility.

■ 105. OTHER SYSTEMS.—*a.* Firings have been conducted using single-station observation with central tracer control. In this system, the adjusters both observe and adjust fire from their positions at the control box. Although this system eliminates the use of a telephone system for communication with spotters, it is not considered satisfactory as it makes observation dependent on depth perception and therefore limits the effectiveness of the central tracer control unit to ranges far within its potential effective range.

b. Attempts have been made to eliminate the control box, and to have spotters adjust fire of all guns simultaneously from the spotting positions. Such a system, sometimes referred to as "remote tracer control," would be advantageous. However, a satisfactory data transmission system for service conditions must be designed before this method of fire adjustment can be used. (See sec. V.)

■ 106. ADVANTAGES AND DISADVANTAGES OF CENTRAL TRACER CONTROL.—*a.* The principal advantages of central tracer control over individual tracer control are as follows:

(1) The effective range is much greater.

(2) The guns shoot together, resulting in a smaller cone of fire, which is easier to observe and to adjust.

(3) The lateral and vertical leads are handled separately, permitting each adjuster to concentrate on one lead.

(4) Personnel adjusting fires are placed away from the guns, thereby avoiding interference from the smoke, flash, and vibration of the gun and the handicap of handling the gun.

(5) Fewer personnel thoroughly trained in estimation of leads and fire adjustment are required.

b. The principal disadvantages of central tracer control when compared with individual tracer control are as follows:

(1) A data transmission system is required.

(2) The system is not satisfactory for use against surprise targets.

SECTION IV

FIRE ADJUSTMENT

■ 107. GENERAL.—*a.* Fire adjustment for automatic weapons is an operation which is continuous from the instant the first

rounds reach the vicinity of the target until **CEASE FIRING** is given. Each individual adjustment of fire is an adjustment of the rate of change of leads rather than a change in the lead itself. In the case of a coming-diving course where the target dives directly at the gun position, this adjustment is fairly simple because the rates of change of leads remain fairly constant. However, for most target courses the rates of change of leads are changing constantly. In such cases the adjusters must anticipate these changes and modify their adjustments accordingly.

b. (1) The problem of adjusting fire is further complicated by the delay between the observing of a deviation from the target and the arrival of the adjusted rounds at or near the target. The major part of this delay is time of flight except at very short ranges. It also includes time lag in observing deviations and in applying corrections. A disregard of this delay in adjusting fire will result in constant over-correction.

(2) The magnitude of this delay is shown by considering a caliber .50 machine gun firing at a 300 mph target on a crossing-constant altitude course with R_m equal to 600 yards and H equal to 500 yards. Fire is opened when the target is 1,000 yards from the midpoint on the approaching leg and continues until the target is 1,000 yards from the midpoint on the receding leg. The total time of firing is $\frac{2,000}{150}$ or 13.3 seconds. The time of flight of the initial rounds will be approximately $1\frac{1}{2}$ seconds. These shots must be observed, and adjustment made, and the adjusted rounds travel from the guns to the target before the effect of the initial adjustment can be observed. In this particular case the total time from **COMMENCE FIRING** to observation of the effect of the first adjustment will be about 3 seconds, or nearly one-fourth of the firing time. The time from the instant of observation to the instant when the adjustment takes effect at the target is about $1\frac{1}{2}$ seconds.

(3) It is apparent that once an adjustment of fire is obtained, the adjuster must constantly anticipate variations in the rate of change of leads by the time of delay in adjustment if the cone of fire is to continue to pass through the target.

■ 108. INDIVIDUAL TRACER CONTROL.—*a.* In individual tracer control, adjustment of the rate of change of leads is accomplished by the gunner by varying the rate at which he swings his gun laterally and vertically.

b. The best initial training in this fire adjustment is firing at free balloons drifting with the wind. These targets have the following three important advantages:

(1) Rates of change of leads are practically constant, permitting the effect of any change in the rate of change of leads to be readily noted.

(2) Ranges are very short, making time of flight very short, and causing adjustments to take effect at the target almost immediately.

(3) Hits are signaled by the immediate bursting of the balloon.

c. When the gunner has gained confidence in his ability to adjust fire, he is allowed to fire on towed targets to speed up the action and to introduce the problem of constantly varying rates of change of leads. This firing should, if practicable, be supplemented by use of the tracer control trainer, described in chapter 9, particularly using service speeds.

■ 109. CENTRAL TRACER CONTROL.—*a.* In central tracer control, leads and adjustments of leads are applied by the adjusters at the control box by turning the adjusting knobs. Adjusters not only must have a knowledge of how to estimate leads, but also must know how these leads change throughout the course in terms of "rate of turning" of the handwheels. They must know not only how fast to turn the handwheel but also in which direction to turn it. Starting to turn in the wrong direction when adjusting fire will often eliminate any chance of placing fire on the target during the course. As in the case of individual tracer control, firing at balloons drifting with the wind is good initial training as it gives the adjusters confidence in their ability and teaches them how to handle the adjusting knobs. It does not, however, teach the required rate of turning for a fast-moving target. For this training, firing on towed targets must be employed. Even this firing will not be against targets traveling at service speeds. For training against

targets traveling at service speeds, reliance must be placed on the tracer control trainer described in chapter 9.

b. (1) Following is a table showing the large variations in rate of change of leads (lateral and vertical) for a caliber .50 machine gun firing at a 300 mph target on a right to left crossing-constant altitude course having $R_m=600$ yards and $H=500$ yards. Fire is opened when the target is 1,000 yards from the midpoint on the approaching leg, and continues until the target is 1,000 yards past the midpoint. The initial leads are: lateral=left 118 mils; vertical=+80 mils. The leads and rate of change of leads per second at the end of each second of travel are as follows:

At the end of second	δ_L (mils)	Rate of change in δ_L (mils/sec)	σ_L (mils)	Rate of change in σ_L (mils/sec)
1st.....	Left 129.....	Left 11.....	+78	Down 2.
2d.....	Left 142.....	Left 13.....	+73	Down 5.
3d.....	Left 160.....	Left 18.....	+66	Down 7.
4th.....	Left 185.....	Left 25.....	+55	Down 11.
5th.....	Left 196.....	Left 12.....	+35	Down 20.
6th.....	Left 199.....	Left 3.....	-12	Down 47.
7th.....	Left 196.....	Right 3.....	-46	Down 34.
8th.....	Left 190.....	Right 5.....	-63	Down 17.
9th.....	Left 179.....	Right 11.....	-75	Down 12.
10th.....	Left 163.....	Right 15.....	-81	Down 6.
11th.....	Left 148.....	Right 15.....	-83	Down 2.
12th.....	Left 137.....	Right 11.....	-80	Up 3.
13th.....	Left 128.....	Right 9.....	-76	Up 4.

(2) From the foregoing tabulation, it is evident that the rate of change of leads for this particular course and speed of target varies from a "Left 25" to a "Right 15" mils per second rate of change in lateral lead and from a "Down 47" to an "Up 4" mils per second rate of change in vertical lead. The lateral rate of change of leads increases and then decreases on the approaching leg, reaching zero at about the midpoint, then increasing in the opposite direction until the 11th second, when it starts decreasing again. The vertical rate of change of leads increases negatively at a rapid rate until the 6th second, then decreases again until it reaches 0 rate some distance past the midpoint, then gradually increases in a positive direction.

c. If the adjuster, upon noting that the cone of fire is ahead of the target, stops his turning of the adjusting knob until the cone of fire passes through the target, the cone of fire will fall behind the target at a time interval (the time of flight) after correct adjustment was observed. Further, the adjuster will have difficulty in resuming the correct rate of turning of the adjusting knob. *Adjustments of fire must be made by smooth variations in the rate of turning of the adjusting knobs, and not by intermittent stopping and turning of these knobs.*

SECTION V

DATA TRANSMISSION

■ 110. GENERAL.—*a.* No data transmission system is required when using individual tracer control.

b. When using central control, some form of data transmission system is required. The data transmission system must permit application of leads to the gun sights continuously and practically instantaneously, as any delay in changing leads makes fire adjustment useless since dead time (the interval from observation to firing of the adjusted rounds) will become excessive. The system must function efficiently during the shock and noise of firing, must permit free movement of the gun, and must not interfere with the action of the gunner.

c. There are three general methods of data transmission: telephonic, mechanical, and electrical. They may be used separately or in any combination, depending on the system desired and the equipment available.

■ 111. TELEPHONIC DATA TRANSMISSION.—When this type of transmission is employed, spotters are directly connected by telephone with the assistant gunners. Spotters continuously indicate the lateral and vertical leads. Initial leads and changes in leads, as received from the spotters, are set on the sights by the assistant gunners. This operation is difficult to perform smoothly, particularly when the mount is vibrating from gunfire, and may interfere seriously with the gunner. This system is not very rapid. In addition, the assistant gunner frequently has difficulty in understanding the

spotter while the gun is firing. Because of the above deficiencies, a telephonic data transmission system is not considered satisfactory except as an emergency method.

■ 112. MECHANICAL DATA TRANSMISSION.—*a.* Mechanical data transmission has been tried at different times with various types of shafting. The best mechanism employs flexible shafts, which are used in the standard central control system. In this system lateral and vertical leads are set on scales in the control box (see fig. 78). In matching indexes, two operators turn handwheels controlling the rotation of flexible shafts which, through gearing, cause the sights on each gun to be moved the proper amount laterally and vertically.

b. In the standard system, telephonic data transmission is combined with the mechanical data transmission system. In this standard system, lateral and vertical leads are set into the control box in the following manner. Telephone lines are arranged so that each spotter can be connected by telephone with either of the adjusters at the control box to permit his use either as a lateral spotter or as a vertical spotter. Since adjusters are provided with helmets, the telephone communication will not be appreciably affected by the noise of firing.

■ 113. ELECTRICAL DATA TRANSMISSION.—An electrical data transmission system which would permit the spotters to control directly the movement of the gun sights would be the best possible transmission system. At the present time, no such system is available. However, a similar system has been used wherein self-synchronous transmitters and receivers were employed for lateral and vertical lead transmission. Each receiver had an electrical index controlled by the transmitter and a mechanical index which controlled the movement of the sight laterally or vertically by means of a short flexible shaft. When the indexes were matched, the transmitted leads were set on the sights. This system provides transmitters for only one lateral and one vertical observer and does not permit direct control of the gun sights by the spotter. Until these problems are solved, the telephonic-mechanical system is the best available.

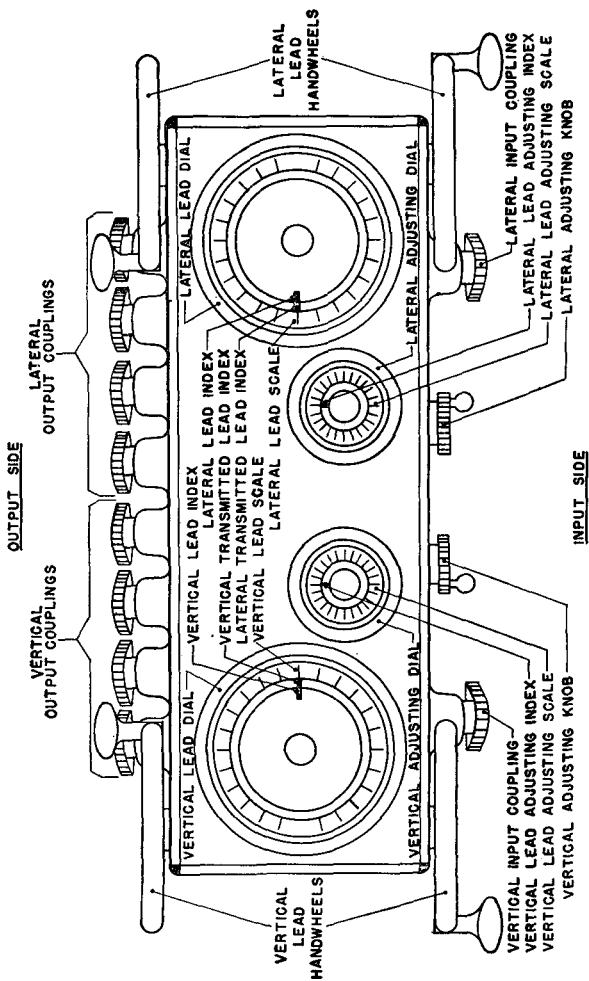

FIGURE 78.—Control box for automatic gun, anti-aircraft, control equipment set M1.

CHAPTER 8

RANGE SECTION

■ 114. GENERAL.—*a.* A range section is required whenever antiaircraft automatic weapons units fire with central control or director control.

b. For units which are equipped with the control equipment sets M1, the same central control equipment is provided for both antiaircraft machine-gun platoons and 37-mm antiaircraft gun platoons. Therefore, except for the allotment of basics, the assignment of personnel for the range section of each of these types of platoons is identical. These personnel are assigned to the platoon headquarters and range section.

c. The details of the organization of the range section for director control (M5 or M6) are covered in FM 4-113.

■ 115. ORGANIZATION.—*a.* The following table shows the personnel assigned to the platoon headquarters and range sections of mobile machine gun units, and mobile and semimobile 37-mm gun units when equipped with control equipment set M1.

Organization, platoon headquarters and range section

Unit	Machine gun unit	37-mm gun unit	
	Mobile	Mobile	Semimobile
First lieutenant	1	1	1
Sergeant, including	1	1	1
Platoon	(1)	(1)	(1)
Corporal, including	2	2	2
Communication	(1)	(1)	(1)
Instrument	(1)	(1)	(1)
(in charge of central control equipment)			
Private, first class } including	16	15	13
Private }			
Chauffeur	(2)	(2)	(0)
Observer and spotter	(8)	(8)	(8)
Operator, central control equipment	(2)	(2)	(2)
Operator, telephone	(2)	(2)	(2)
Basic	(2)	(1)	(1)
Total enlisted	19	18	16

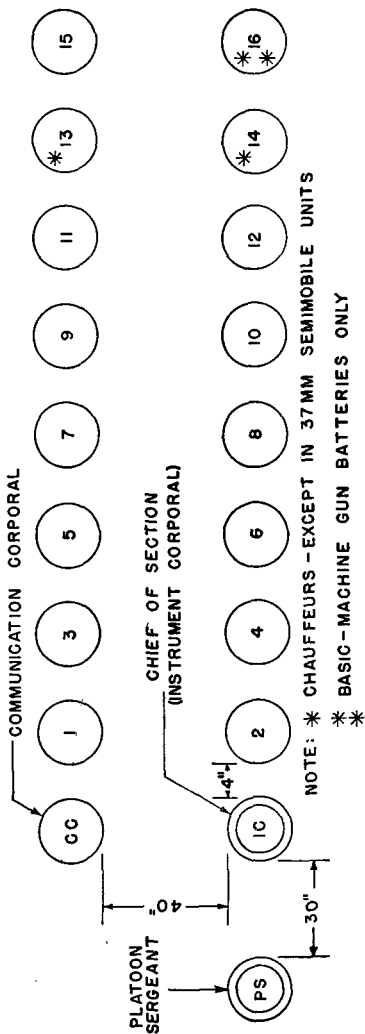

FIGURE 79.—Formation for automatic weapons platoon headquarters and range sections.

b. Members of the platoon headquarters and range sections of antiaircraft automatic weapons batteries are designated as follows:

PS_____	Platoon sergeant.
IC_____	Instrument corporal (chief of section).
CC_____	Communication corporal.
No. 1_____	Vertical adjuster.
No. 2_____	Lateral adjuster.
No. 3_____	Vertical matcher.
No. 4_____	Lateral matcher.
Nos. 5-10, incl.	Observers and spotters.
Nos. 11 and 12.	Telephone operators.
Nos. 13 and 14.	Chauffeurs (except in 37-mm semimobile units).
No. 15_____	Basic.
No. 16_____	Basic (machine-gun batteries only).

Duties of members of the range section are found in the drill table, appendix IV.

c. The formation for automatic weapons platoon headquarters and range sections is shown in figure 79.

■ 116. EQUIPMENT.—*a. General.*—(1) The central control equipment used by the range section for central tracer control is the automatic gun, antiaircraft, control equipment set M1. This set consists of a control box for setting and adjusting the leads, a number of flexible mechanical shafts for transmitting the leads set on the control box to the sights of the guns, and the necessary packing chests.

(2) In addition to the control set, selective telephone communication is provided between the spotters and the adjusters. This equipment includes the necessary telephones and headsets, the necessary field wire, and a special switching arrangement which permits direct communication to be quickly established between a particular adjuster and any one of the spotters.

(3) Glasses with red filters are provided for use by the adjusters and spotters in observing the tracers.

b. Care and preservation.—(1) *Control box.*—(a) All moving parts of the control box are mounted on ball bearings

which are lubricated at the time of assembly by the manufacturer. These bearings, as well as all gears and worms, are lubricated only at long intervals by ordnance maintenance personnel.

(b) The protective covers should be kept screwed on each coupling except when a flexible shaft is connected to the coupling.

(c) Keep the control box stowed in the steel packing chest when not in use.

(d) Due to cold weather, malfunctioning of matériel, the use of shafts coupled together, or a combination of these, the mechanism may work stiffly. If this occurs, do not force the handwheels. Determine and correct the difficulty before resuming operation of the control box.

(e) Keep the control box clean by wiping all water and dirt from the outside before stowing it. Keep the dial windows clean to insure visibility of the scales and indexes. Keep the ends of the couplings clean and lightly coated with oil.

(2) *Flexible shafts.*—(a) Protective covers are provided for all couplings and should be screwed in place when the flexible shafts are disconnected. When two flexible shafts are screwed together, the protective covers at the union should be screwed together also, to prevent entry of foreign matter into the threads.

(b) Do not kink flexible shafts or bend them on too short a radius when laying them between the control box and other related equipment.

(c) Never subject the flexible shafts to crushing or to chafing by rubbing against a moving object. *Stepping on or running a vehicle over a shaft may injure it.* Do not lay the shafts over a hard surface if it can be avoided. In semi-permanent positions it may be possible to bury the shafts a few inches under the ground surface.

(d) *Do not drag flexible shafts over the ground.* Lay them in place.

(e) The ball bearings in the ends of the shafts are packed with lubricant when assembled. They need lubrication only at long intervals. Keep the ends of the couplings clean and lightly coated with oil. Do not apply oil to the rubber

casing as this will materially reduce the life and wearing qualities of the rubber.

(f) Keep the flexible shafts in the wooden packing chests provided when not in use. Wipe all water and dirt from the shafts before they are stowed.

c. Equipment for case III firing is not included herein as this manual covers only case I firing. Case III firing (director control) is covered in FM 4-113, and the technical details of the 40-mm antiaircraft gun M1 are contained in TM 9-252.

CHAPTER 9

TRAINING

	Paragraphs
SECTION I. General.....	117-120
II. Training of gunners and gun pointers.....	121-123
III. Training of adjusters and spotters.....	124-127
IV. Tracer control trainer.....	128-133
V. Subcaliber firing.....	134

SECTION I

GENERAL

■ 117. PHASES OF TRAINING.—Training in antiaircraft automatic weapons firing is divided into three distinct phases: preliminary training, individual firing, and platoon firing.

■ 118. PRELIMINARY TRAINING.—All personnel are given training during the preliminary training phase. The part of this training pertaining to gunnery includes gun pointing, the estimation of leads, and proper methods of observation and adjustment of fire. Personnel showing particular aptitude during this training should be selected tentatively for the key positions of gunners, adjusters, and spotters.

■ 119. INDIVIDUAL FIRING.—When preliminary training has been completed, individual firing at moving targets is begun. This includes firing at free balloons (released in a wind) and towed sleeve targets. Balloon firing will be only for training in individual tracer control and central tracer control on machine guns, and subcaliber firing on the 37-mm. The purpose of balloon firing is to familiarize personnel with the operation and “feel” of the gun, to test their reaction when firing the gun, and to test ability to adjust fire. This balloon instruction is followed by individual firing at towed sleeve targets. Normally only those men who have shown some ability as gunners, either in previous training periods or during the balloon firing just completed, are allowed to fire at towed sleeve targets. As a result of this towed target firing, the key personnel for preliminary platoon firing are selected.

■ 120. PLATOON FIRING.—Platoon firing, by such units as are equipped with control equipment set M1, includes preliminary and record service practice. The purpose of preliminary firing is to give gunners, adjusters, and spotters intensive training as a team, and to permit final selection of key personnel. The purpose of record service practice is to give additional training to the selected personnel and to record the state of training attained by the unit.

SECTION II

TRAINING OF GUNNERS AND GUN POINTERS

■ 121. GUN POINTING.—*a.* As stated in paragraph 40*a*, accurate gun pointing is essential if the cone of fire is to be kept relatively small when firing by case I. Such gun pointing can be attained only by thoroughly familiarizing the gunners (or gun pointers) with the characteristics and “feel” of the gun and mount; by training the gunners (or gun pointers) in the operation of tracking high speed aerial targets; and by conducting fire to permit the gunners (or gun pointers) to become accustomed to the shock, smoke, and flash of firing and to the vibration of the mount or carriage.

b. In pointing machine guns, gunners should be given practice in assuming a proper position, so as to be able to pick up quickly, and follow smoothly and accurately, targets in any part of the field of fire. Play in the mount should be carefully eliminated, and the mount should be kept well lubricated and adjusted so that it traverses and elevates easily.

c. In pointing the 37-mm gun, the gun pointers must learn to operate the handwheels smoothly at the two speeds provided. Each must learn how to change from one speed to the other without seriously interfering with the tracking by the other gun pointer. Where possible, the same tracking speed is used throughout the course.

d. The requirements of safety normally prevent anti-aircraft automatic weapons units from firing at targets towed at very low altitudes and at extremely short ranges. Since surprise attacks of this type can be expected during combat, opportunity for fire may best be secured by the use of rockets

and radio-controlled planes. The rocket target has been developed in order to introduce into automatic weapons training the degree of alertness and speed required under combat conditions. For instructions for the use of rocket targets by anti-aircraft units, see TM 4-236.

■ 122. ESTIMATION OF LEADS.—*a.* To provide training for occasions when central tracer or director control cannot be used, the gunners (or gun pointers) must be trained in the estimation of required leads, observation of tracers, and rates of change of leads for individual tracer control.

b. Every sportsman knows how difficult it is to train himself to shoot ahead of a flying bird. Similarly, the beginner in automatic weapons firing tends to aim directly at the target and must be trained to ignore this instinctive desire. The necessity for taking adequate lateral leads should be emphasized from the beginning. It should be stressed that it is easier to adjust fire smoothly when the initial lateral lead is too great than when it is too small, and that hits on the forward part of an airplane are more destructive than those on the tail of the airplane, due to the location of the pilot, controls, engines, and gasoline tanks.

c. Training should begin with classroom work in the fundamental principles. The gunners (or gun pointers) are shown typical lead curves and charts, and their use is explained. Then as much time as possible should be provided in lead training. (See secs. III and IV.)

d. Where the time for training in the estimation of leads is brief, one method sometimes employed is to have the gunners (gun pointers) learn to estimate initial leads in target lengths measured along the course of the target. A practical rule for estimating quickly the required lead is to take a lead of one target length for each 100 yards of slant range for each 100 miles per hour of target speed. Thus, for a 100-mile-per-hour airplane at 500 yards' slant range the estimated lead would be 5 target lengths, and for a 200-mile-per-hour airplane at the same slant range the estimated lead would be 10 target lengths. Although the estimate is only approximate and tracking an exact number of target lengths ahead of the airplane until fire is opened is difficult, the method is suffi-

ciently accurate to give the gunner some idea of the proper initial leads and some chance of adjusting his fire. This method is applicable only to individual tracer control.

NOTE.—By target length is meant the apparent length of the target as seen from the observer's position at the instant the initial lead is estimated.

■ 123. **IMMEDIATE ACTION.**—Immediate action is the procedure used for the prompt reduction of usual stoppages, particularly for machine guns. Although immediate action is connected strictly with the service of the piece rather than with gunnery, it definitely affects the latter. Unless a continuous stream of tracers is kept flowing from the gun to the vicinity of the target, the adjustment of fire cannot be successfully accomplished. Furthermore, unless the gun is cleared of stoppages quickly and smoothly, no further firing on a target course will be possible once a stoppage occurs. It is essential that gunners (or gun pointers) be proficient in the duties of immediate action as described in FM 4-135.

SECTION III

TRAINING OF ADJUSTERS AND SPOTTERS

■ 124. **GENERAL.**—Much of the training of adjusters and spotters (for units employing central tracer control) can be conducted during the preliminary phase of training. This preliminary work includes a detailed study of lead curves and charts and the proper operation of the control box. If a tracer control trainer is available, it will assist in teaching both adjusters and spotters, as well as provide the initial training in the adjustment of fire.

■ 125. **STUDY OF LEAD CURVES AND CHARTS.**—Adjusters and spotters should be selected who are able to grasp readily the meaning and purpose of lead curves and charts. They should be carefully trained in the several uses of curves and charts. They should be required to study these curves and charts frequently until they have become familiar with the correct initial leads and rates of change of leads at various points along a number of type courses for targets traveling at different speeds. (For a discussion of lead characteristics, see ch. 5.)

■ 126. OPERATION OF CONTROL BOX.—*a.* The best preliminary method of teaching the adjusters to operate the control box is to train them on the tracer control trainer discussed in section IV. The best training for operation of the control box is, of course, actually operating the box during a target's course.

b. (1) Where no tracer control trainer is available, lead charts may be used to familiarize adjusters with the setting of leads and the rates at which the adjusting knobs must be turned at various points of typical courses.

(2) One procedure in teaching the operation of the control box by the use of lead charts is as follows:

(*a*) Using the same scale as that of the lead chart to be employed, make up several scales each of which is marked with lead values at intervals of 2 seconds of linear travel for a particular target ground speed. For example, a scale for 200 miles per hour would be divided into 200-yard intervals. The marks need not be labeled in terms of seconds unless desired, but the scale of yards to the inch and the target ground speed represented should be shown as well as the lead values.

(*b*) The control box having been set up, the adjusters take position opposite their respective adjusting knobs. Beside each adjuster is a coach with the proper lead charts and a set of the speed scales described in (*a*) above.

(*c*) When the instructor designates a course and target ground speed, each coach places the proper speed scale along the proper course line with the first mark of the scale opposite the left (constant altitude charts) or outer (dive charts) end of the course with scale extending in the direction of flight as shown on the chart.

(*d*) Each coach calls off the lead value (initial lead) opposite the first mark of the scale, and the values are set on the proper adjusting dials by the adjusters. The instructor checks to see that the leads are set on in the proper direction.

(*e*) At the command TRACK given by the instructor, the coaches call off values of mils opposite the marks of the scale successively at 2-second intervals. (These intervals may be determined by stop watch if desired.) The adjusters turn

the adjusting knobs at the proper rates to cause the proper readings of the adjusting dials to pass their respective indexes as they are called off by the coaches. Coaches continue to call off lead values until the end of the course is reached or the command **CEASE TRACKING** is given.

(3) As the training progresses, refinements can be added to the above procedure. Some of these are—

(a) Adjusters may be required to call off the required initial leads for the course and speed indicated without reference to charts. The instructor checks for errors the values given.

(b) After **TRACK** is given, adjusters may be required to turn the adjusting knobs at estimated rates of lead changes without assistance from the coaches. This may be varied by having the coaches assist the adjusters by reporting high, good, or low, or right, good, or left throughout the course to simulate reports from the spotters. Records of the leads set by adjusters during these courses can be taken and plotted against the correct leads for those courses to demonstrate the progress of adjusters in familiarizing themselves with required leads.

(c) To check familiarity with the operation of the control box, adjusters can be blindfolded and then required to set initial leads and maintain correct rates for a prescribed course.

(4) Another method of providing training in the operation of the control box with the use of lead charts is as follows:

(a) Provide a "running rabbit" type of miniature target in a room or at the gun position. Prepare a set of lead charts for all types of target courses constructed.

(b) Standard lead charts show mil-ray lines radiating from the *gun* position of the chart. These lines are drawn at 200-mil increments. On a crossing course chart these lines can be used to locate the position of the target along the R_m line, and on a coming course chart these lines can be used to locate the position of the target along the H_m line.

(c) The values of the leads are written on the lead charts where the mil-ray lines cross the R_m (H_m on incoming course)

lines. (Enough charts should be provided to include all probable service targets of various ranges, altitudes, speeds, and angles of dive.)

(d) A coach, with the proper chart, is stationed beside each adjuster.

(e) The target takes course. The instructor calls out the data that must be estimated for any automatic weapon target; that is R_m , H_m , S_g , and angle of dive. These data determine for the coach the proper lead scale to be used on that course.

(f) The command TRACK is given by the instructor. He then estimates and calls out the position of the target along its course in terms of the value of the angle target-gun-midpoint.

(g) As the instructor calls out this angle, the coach calls out to his adjuster the proper lead value for the target's position at this point.

(h) The adjuster sets the initial lead at the command TRACK and starts to turn his adjusting knob in the proper direction. At the same time, he attempts to turn his adjusting knob at the proper rate so that he will have the correct lead set on his dial every time the coach calls out a new value. If he has not turned at the proper rate and does not have the proper lead set when the coach calls the next lead, he will immediately readjust this dial and attempt to be at the right value the next time a value is called.

(i) This process continues until the command CEASE TRACKING is given by the instructor.

(5) This method is of especial value in preliminary firing. It teaches the adjusters to set the correct lead for particular targets and to turn the adjusters' knobs at the proper rates. Further, it insures opening fire comparatively close to the target, and this means that fire adjustment will be easier and faster.

■ 127. TRAINING IN ADJUSTMENT OF FIRE.—A thorough knowledge of lead characteristics is a prerequisite to the inauguration of training in fire adjustment for automatic weapons. In the initial step of this training, adjusters and spotters must be taught the basic principles of observation

and adjustment of fire as outlined in chapter 7. The next step is practical adjustment of fire using the tracer control trainer as described in section IV, if such a trainer is available. Training in the adjustment of actual firing is then begun, starting with balloon targets and progressing to towed targets. This adjustment of fire is performed as described in chapter 7, instructors noting errors in performance and correcting them after each course. Usually the amount of ammunition available will be limited, and the use of subcaliber guns must be resorted to in order to obtain the maximum possible training in fire adjustment (see sec. V).

SECTION IV

TRACER CONTROL TRAINER

■ 128. GENERAL.—*a.* The tracer control trainer has been developed to provide training for men of antiaircraft automatic weapons batteries in estimating and applying leads through central control equipment. It has been found that by means of the trainer, observers and operators of the control equipment set M1 can become quite expert in their duties. After such preliminary training, they are able to put effective automatic weapons fire on the target with a minimum expenditure of ammunition.

b. The general purposes of this trainer are to—

(1) Provide personnel with a visible example of a tracer stream and to demonstrate the effect on such a stream of the movement of the adjusters' knobs.

(2) Familiarize adjusters with the magnitude of leads and rates of lead changes for type courses and afford practice in the operation of the adjusting knobs in applying these leads.

(3) Familiarize the adjusters with the appearance of the tracer stream in space, and its proper relation with respect to the target.

(4) Train the adjusters in adjusting fire with the aid of spotting.

(5) Train the spotters in calling the sense of the tracer stream deviation.

(6) Train pointer matchers in matching the indexes of the lead dials of the control box and anticipating the direction and rates of lead changes.

(7) Familiarize personnel operating the lead control unit with the leads and rates of change of leads for different courses and target speeds.

■ 129. DESCRIPTION AND USE OF TRAINER.—*a. General.*—The trainer consists of three principal parts: the trajectory tunnel, the lead control unit, and the standard control box. These parts are connected by means of flexible shafting. (See fig. 80.)

b. Trajectory tunnel.—(1) The trajectory tunnel is that part of the trainer which contains the apparent tracer stream and the target. The tracer stream consists of a series of small electric lights mounted on a curved rod and built to scale so that it will give the appearance of a stream of tracers directed against a moving target. The target consists of an illuminated miniature airplane or sleeve target.

(2) The tracer stream and target are built so that they can be mechanically displaced from each other in both a lateral and a vertical direction. Displacement of the trajectory laterally is controlled by the lateral handwheel of the control equipment set M1, while displacement of the target vertically is controlled by the vertical handwheel of that set.

(3) The small lights representing the tracers are connected in four circuits of an equal number of lights per circuit. By use of a rotary switch operated by a constant speed motor, the lights of each circuit are turned on and off in sequence, giving the appearance of tracers moving out from the point of observation (gun position) toward and beyond the target. A switch is included in the circuit so that the tracer stream can be turned *on* and *off* to represent COMMENCE FIRING and CEASE FIRING. Another control provides for simulation of machine-gun fire, "fast," or 37-mm gun fire, "slow." A rheostat controls the brilliance of the lights in the tracer stream. These lights should just glow.

(4) To eliminate depth perception, except by one object concealing another, the tracer stream and target are inclosed

in a lightproof box so that only the illuminated target and the small flashing lights of the tracer stream can be seen. A system of mirrors is arranged at the front end of the box to bring the lines of vision of the two observers together so that both lateral and vertical adjusters see the relation between the tracer stream and target from approximately the same point.

c. Lead control unit.—(1) The lead control unit is mounted on the left side (looking from the gun or control end) of the trajectory tunnel. Correct leads, laterally and vertically, are shown as plotted curves. When following these curves, the unit mechanically transmits, by means of the flexible cables, correct lateral and vertical leads into the control equipment set M1. These leads are introduced into the control box through the input side and are in the opposite sense to the true leads. The lead control unit consists of a set of lead curves for various courses, two transmitters with pointers for following the curves (lateral and vertical), and a driving mechanism to move the curves past the pointers at a uniform rate. Twelve sets of lead curves are provided, each mounted on a section of fiber board.

(2) The transmitters consist of handwheels connected through gearing both to flexible shafts, which in turn are connected to the input couplings of the control box, and to racks acting as pointers for following the curves. The gear ratios are such as to turn the shafts one turn for each 8 mils' movement of the pointer up or down the ordinate scale. (The input connections of the control box operate at 8 mils per turn.)

(3) Two rubber rollers mounted on a shaft, and driven by a constant speed motor, are used to move the lead control curves past the pointers at a uniform rate. The set of curves is started and stopped by means of a clutch. By following the designated lead curves with the pointers as the chart moves past them, the leads are transmitted to the input side of the control box.

d. Control equipment set M1.—(1) The control equipment set M1 is used to control the relative movement of the target and tracer stream and to receive the transmitted data from the lead control unit. The control box is mounted under the

observing end of the trajectory tunnel and receives the leads transmitted from the lead control unit through the input couplings. These leads are combined by the control box differentials with the input of leads from the adjusting knobs to offset the lead indexes (inner pointer). The differences between the control unit leads (opposite in sign from true leads) and the adjusters' estimates are transmitted, by matching indexes of the lead dials, to the trajectory tunnel, where they offset the target and tracer stream from each other by the same number of mils.

(2) Flexible shafts of the control equipment set M1 are used to connect the main parts of the trainer as follows: Two shafts connect the vertical transmitter and lateral transmitter of the lead control unit to the vertical input coupling and lateral input coupling, respectively, of the control box. Two other shafts connect a vertical output coupling and a lateral output coupling of the control box to the vertical connection and lateral connection, respectively, of the trajectory tunnel.

(3) When the adjusters are setting in the correct leads, the lead indexes will be at the normals of the lead scales. At other times the reading on the lead scales gives the amount of error in the leads being set by the adjuster.

(4) The lead transmitted indexes (that is the outer pointers) indicate the position of the target and tracer stream with respect to each other. As the indexes of the lead dials read normal when the target is in the tracer stream, these indexes can be used for checking the accuracy of the adjuster. By glancing at the lead dials, the instructor can tell the sense and amount of the deviations of the tracer stream from the target. If the error remains constant the initial lead was wrong but the rate of change of lead is correct. If the index starts at normal and then gradually swings away from it, the rate is too great or too small. If the index constantly moves toward and away from normal in an erratic manner, the adjusters' estimate of rates is erratic.

(5) The lead indexes can also be used to simulate spotting. To do this, place a curved strip of paper or tape just outside the scale of each lead dial at the normal with a colored section, marked "good," extending 5 or 10 mils on each side of

normal. The tape on the proper sides of this "good" sector is marked "right" or "left" on the lateral dial, and "high" or "low" on the vertical dial. The pointer matchers (simulating spotters) note the position of the indexes on their lead dials and throughout the course continuously call off the position of the tracer stream with respect to the target as indicated by the labeled sections of the tape.

■ 130. DRILL WITH TRAINER.—*a. General.*—The drill with the trainer is logically divided into the following phases:

(1) Practice runs where the adjusters learn only the proper rate and the correct direction of turning the adjusters' knobs.

(2) Target runs where the adjusters open with the proper amount of initial leads and attempt to keep the target in the tracer stream by watching the effect of their adjustments in the trajectory tunnel.

(3) Target runs where the adjusters estimate the initial leads with the help of lead charts, and during the course attempt to keep the target in the tracer stream by watching the effect of their adjustments in the trajectory tunnel.

(4) Target runs where the leads set by the adjusters are recorded and later analyzed by the adjusters with the use of lead charts or master curves. The preliminary selection of potential adjusters is made by a short course of instruction using the first two phases listed above. These men previously selected can then be given more intensive training using all four of these phases.

b. Preliminary instruction.—(1) Prior to actual drill on the trainer, it has been found extremely helpful to explain to the entire training group the purpose of the trainer and the method of its operation. First, have each man look into the tunnel, the side door being opened. Then have each man observe the tracer stream and lighted target from the observing periscope. Explain and demonstrate that operation of the pointers on the chart displaces the lead (inner) indexes of the lead dials; that if the same lead set at the lead control unit is set on the corresponding adjusting dial, the lead index will return to normal; and that matching indexes (outer pointers matched with inner pointers) on a lead dial by turning the handwheel causes the tracer stream

to be offset from the target by the amount shown on the lead dial.

(2) All men should be cautioned not to step on the flexible shafts. They should also be cautioned against promiscuous turning of handwheels. *Warn that under no circumstances should handwheels be forced.* Handwheels need not be turned very rapidly, and carelessness may result in broken flexible shafts or stripped gears. If it appears that the indexes are too far apart for easy matching, the drill should be stopped until the instructor can rectify the situation.

c. Composition of training groups.—(1) The training group should not be too large, as in such groups individual instruction and proper observation are impossible. A group of 14 men is preferable. This group is divided into two sections, a training section and an observing section. After everyone in the training section has operated each part of the equipment, the sections are reversed and the instruction repeated.

(2) The training section consists of the section leader; a vertical adjuster, No. 1; a lateral adjuster, No. 2; a vertical matcher and spotter, No. 3; a lateral matcher and spotter, No. 4; a vertical lead setter, No. 5; and a lateral lead setter, No. 6 (see fig. 80).

d. Rotation of training section.—Positions of personnel at the trainer equipment are changed at the command **CHANGE DETAILS**, given by the instructor at frequent intervals. The frequency with which positions are changed is dependent on the time factor, but normally changes will be made after two courses are run, one a practice run and the other a target run. Odd-numbered men change to the next lower odd number, except No. 1, who changes to No. 5. Even-numbered men change to the next lower even number, except No. 2, who changes to No. 6. After each odd-numbered man has filled each odd-numbered position and each even-numbered man has filled each even-numbered position, odd-numbered and even-numbered personnel change positions, and the operation is repeated until each man has received instruction in every position.

e. Target.—The section leader commands: **TARGET**, and then reads from the chart to be used the caliber of weapon, R_m , H , and S_g , and the T_o desired as the point to commence

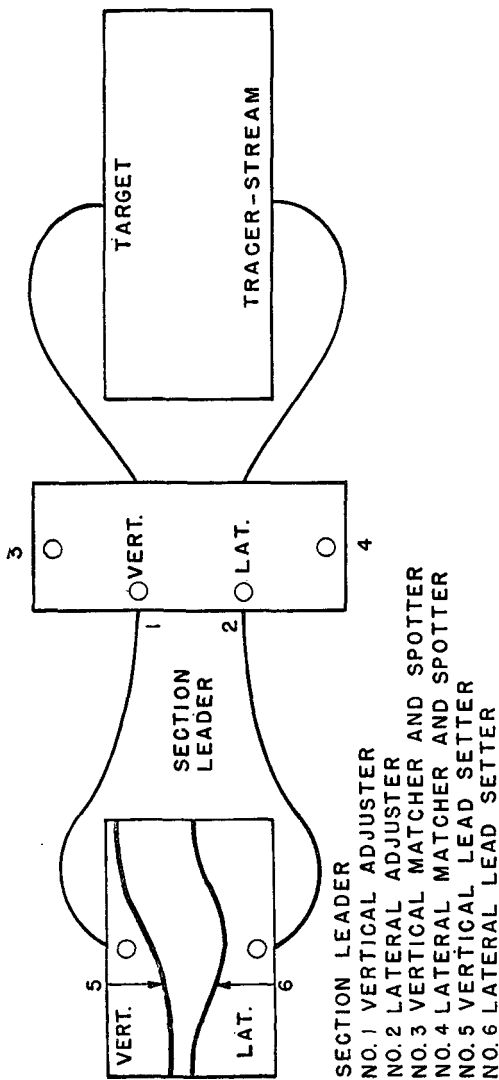

FIGURE 80.—Plan view of trainer, showing positions of operating personnel.

firing. He then asks the adjusters for their estimated initial leads. If these agree with the correct leads as indicated on the lead curve, he indicates that fact; otherwise he corrects the adjusters. The set of lead curves is then inserted in the bottom of the lead control unit through the slot provided for that purpose (lateral curves to the left) and is pushed upward until the pointers are opposite the point indicated by time "zero." *CAUTION: Be sure that the clutch is disengaged before inserting the curves.* The section leader then asks "Ready?" When the adjusters have the leads set in, they reply "Set."

f. Commence firing.—(1) The section leader commands: 1. PRACTICE RUN (OR TARGET RUN), 2. COMMENCE FIRING.

(2) If a practice run has been ordered, Nos. 3 and 4 place their pointers on normal and remain inactive. Nos. 5 and 6 place their pointers on the proper charted curve, and No. 5 throws the clutch controlling the movement of the chart. Nos. 1 and 2 watch their respective lead dials, turning their adjusting knobs at the proper rate to keep the lead indexes of their respective lead dials at normal. Throughout the course they note how fast and in which direction they must turn. At the midpoint of the course, No. 5 calls "Midpoint."

(3) If a target run has been ordered, the section leader throws the switch illuminating the tracer stream. Nos. 5 and 6 proceed as for a practice run. Nos. 1 and 2, by turning the adjusting knobs, continuously set in leads, watching the target in the trajectory tunnel to see that the tracer stream continuously appears to pass through the nose of the target. Nos. 3 and 4 continuously match indexes on their lead dials and continuously sound off their spot observations, according to the position of the indexes, as High-High-High, Good-Good-Good, or Low-Low-Low (vertical matcher), of Left-Left-Left, Good-Good-Good, or Right-Right-Right (lateral matcher). No. 5 calls "Midpoint" at the midpoint of the course.

g. Cease firing.—When the chart has been run entirely through its course, No. 5 commands: CEASE FIRING, and immediately disengages the clutch. Nos. 1, 2, 3, and 4 immediately release their knobs or handwheels and await comments or instructions from the instructor. Nos. 5 and 6

both leave their pointers on the end of the charted curve. All details remain at their posts until the command CHANGE DETAILS is given.

■ 131. SYNCHRONIZATION OF EQUIPMENT.—*a.* Synchronization of the equipment must be accomplished at the start of each training period. This is necessary so that when the lead control unit transmitter pointers and the adjusting dials are at zero lead, the lead indexes will be at normal, and the target will be in the tracer stream. It is always performed by the first training section to man the equipment. The synchronization consists of two operations: synchronization of the lead control unit with the control box and synchronization of the control box with the trajectory tunnel.

b. Synchronization of the lead control unit and control box is performed at the start of drill and when a change is made from a high speed target to a low speed target or the reverse. The latter synchronization is required because the zeros of the ordinate mil scales of these two types of targets are in different positions. The procedure is as follows: Nos. 5 and 6 set their pointers to zero for the type of course (service or target practice) that is to be used. Nos. 3 and 4 set their transmitted lead indexes to normal. (Normal is 500 on 37-mm dials and 300 on machine-gun dials.) Then Nos. 1 and 2 zero the adjusting dials. If the lead (inner) indexes of the lead dials are not then at normal, they disconnect the input flexible shafts at the input couplings of the control box and turn the couplings until the lead index of each lead dial is at normal. They then reconnect the flexible shafts. To check the synchronization, Nos. 5 and 6 set various lead values with their pointers. Nos. 1 and 2 set the adjusting dials to the same readings. The lead indexes should then be at normal in each case.

c. Synchronization of the control box and the trajectory tunnel is accomplished at the start of each training period and also whenever a check of the target and trajectory shows them to be out of synchronism with the control box. The procedure is as follows: Nos. 1 and 2 open the side panel and direct Nos. 3 and 4 in adjusting the lead handwheels until the target is in the tracer stream. When the adjust-

ments are completed, Nos. 3 and 4 note the position of the transmitted lead indexes and, if they are not at normal, disconnect the output flexible shafts, set the transmitted lead indexes at normal by turning their handwheels, and then reconnect the flexible shafts.

■ 132. METHOD OF ADJUSTING LEADS.—*a. Vertical adjuster.*—

(1) In general, vertical leads start at the maximum for the course and constantly decrease until near the end of the course, when they begin to increase again.

(2) The lead being decreased, if his spotter reports "Low-Low-Low," the adjuster gradually reduces his rate of turning of the adjusting knob until the spotter reports "Good." If the spotter reports "High-High-High," the adjuster rapidly increases the rate of turning of his adjusting knob until the spotter reports "Good."

(3) When the vertical lead is increasing, the operations described in (2) above are reversed, the rate of turning of the adjusting knob being rapidly increased when the trajectory is reported to be "Low" and gradually decreased when it is "High."

b. Lateral adjuster.—(1) In general, lateral leads are moderate at the start of the course, increase until near the midpoint, remain fairly constant for a second or two at approximately the midpoint, and then decrease on the receding leg to about the same lead as that at the start of the course.

(2) The lead being increasing, if the spotter reports "Right-Right-Right," the adjuster gradually decreases the rate of turning of the adjusting knob until the spotter reports "Good." If the spotter reports "Left-Left-Left," the adjuster rapidly increases the rate of turning of the adjusting knob until the spotter reports "Good."

(3) The lead being decreased, if the spotter reports "Right-Right-Right," the adjuster rapidly increases the rate of turning of the adjusting knob until the spotter reports "Good." If the spotter reports "Left-Left-Left," the adjuster gradually decreases the rate of turning of the adjusting knob until the spotter reports "Good."

c. Continuation of adjustment.—After the adjustment (lateral or vertical) is completed, the adjuster continues to

change the rate of turning of the adjusting knob as required for a course such as that being flown by the target.

■ 133. ANALYSIS OF TRAINING.—To obtain the maximum advantage from the instruction on the tracer control trainer, a record should be kept of the progress of each individual adjuster throughout his training. The following system of obtaining and recording data from the trainer has been found satisfactory and is recommended for use:

a. After the training section has become familiar with the operation of the trainer, and every man has had at least three courses (one practice run and two target runs) as adjuster, issue one Form for Analysis of Training (fig. 81) to each man. A recorder is assigned to each adjuster for each course. At the beginning of each target run, the section leader announces the course data: type of gun, R_m , H , and S_g . These data are recorded in the spaces provided at the top of the form.

The adjuster estimates the initial lead from the proper chart and the recorder enters it opposite time 0 on the form. The instructor should not correct this initial lead even though it has been estimated incorrectly. During the course, the section leader announces each 4-second interval by calling "Time —," "Ready," "Take," "Take" being given as the proper time line passes the pointers of the lead control unit. At "Take," the recorder reads the correct adjusting dial and records this reading on the form.

b. Each adjuster should have at least two preliminary runs, each run being composed of two courses. The data recorded are analyzed by the adjuster during the period when he is not assigned a particular station on the trainer. After these two preliminary runs, the adjuster is given two record courses. These are recorded by the recorder as was done for the preliminary courses. After being relieved from the adjuster's position, each man plots his two record courses against the corresponding master (computed data) curves. If time permits, each man should be given the opportunity to set in both lateral and vertical leads and be given record runs on both.

ANALYSIS OF TRAINING

Name.....

Grade.....

CENTRAL TRACER CONTROL TRAINER

Group..... Section.....

Battery..... Place..... Date..... Time.....

Vertical

Lateral

Preliminary Runs

Recond Runs

Course	1	2	3	4	5	6
Caliber						
R_m						
H						
S_σ						
TIME						
0						
4						
8						
12						
16						
20						
24						
28						
32						
Adjuster						
Recorder						

Plot record runs against master curves.

NOTE.—Circle appropriate words for heading.

FIGURE 81.—Analysis form for tracer control trainer.

c. By comparing the plotted curves of courses run by the various adjusters with the master curves, and noting an in-

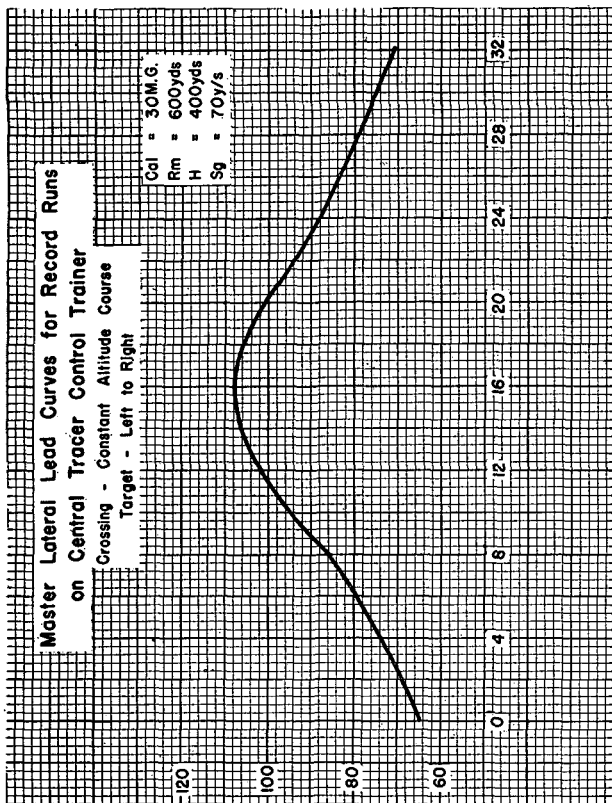

FIGURE 82.—Master lateral lead curves for record runs, caliber .30 machine gun.

crease or decrease in accuracy from training period to training period, the progress of each adjuster can be observed and the best adjusters selected. (See figs. 82 to 85, inclusive.)

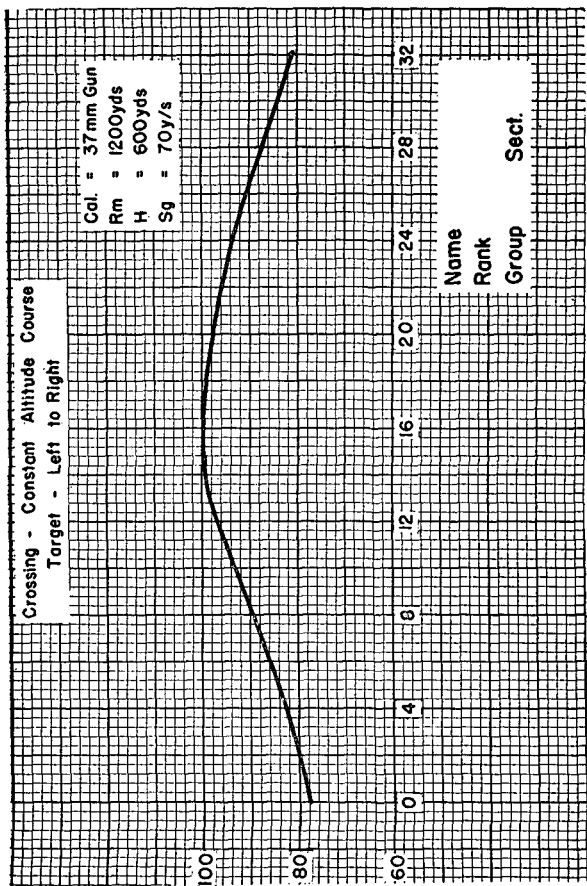

FIGURE 83.—Master lateral lead curves for record runs, 37-mm gun.

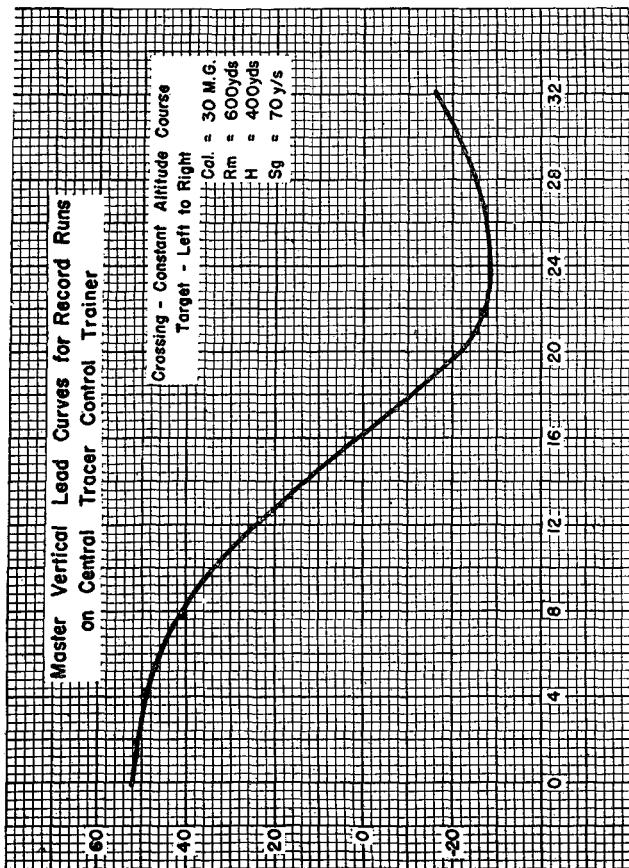

FIGURE 84.—Master vertical lead curves for record runs, caliber .30 machine gun.

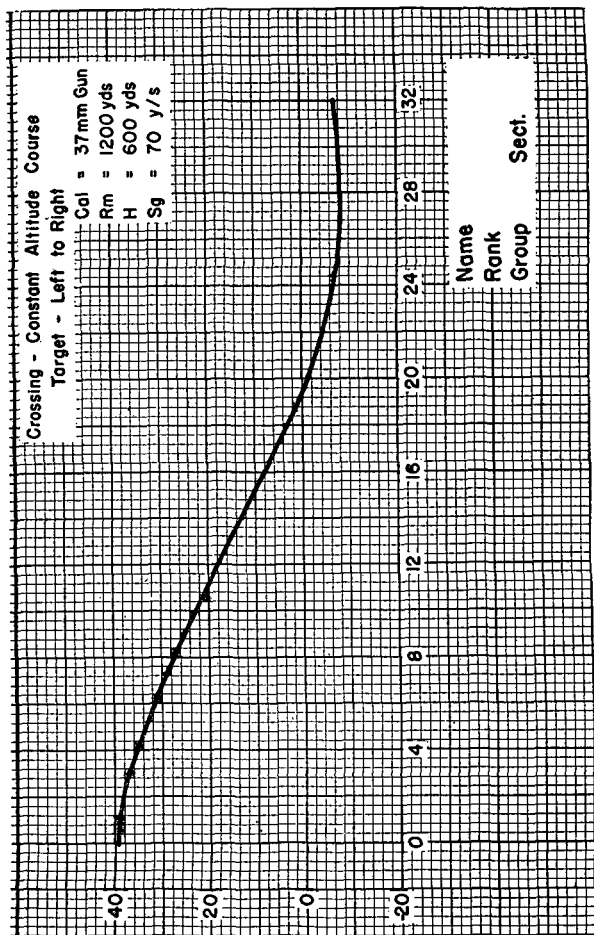

FIGURE 85.—Master vertical lead curves for record runs, 37-mm gun.

SECTION V

SUBCALIBER FIRING

■ 134. GENERAL.—*a.* Due to the large amount of firing necessary to train an antiaircraft automatic weapons fire unit to fire with both central tracer control and individual tracer control, it is contemplated that much of the individual firing and preliminary platoon firing of such units will be done with the caliber .30 machine gun M1917. Special adapters are being provided to mount the caliber .30 machine gun on the M2 antiaircraft machine-gun mounts and on some of the 37-mm gun carriages.

b. During the subcaliber firing, the range section functions as usual, adjusting fire by tracer stream. Lead charts for the caliber .30 machine gun should be studied by the adjusters prior to and during the firing.

c. The ranges for these subcaliber firings are relatively short, being limited by the tracer range of caliber .30 ammunition. Horizontal ranges at the midpoint should be kept to less than 600 yards on crossing courses and altitudes to less than 600 yards on coming courses.

ANTI-AIRCRAFT AUTOMATIC WEAPONS

APPENDIX I

GLOSSARY OF SYMBOLS, AUTOMATIC WEAPONS

The prescribed symbols used with anti-aircraft automatic weapons are given in the list below, arranged in alphabetical order. Both English and Greek letters are used as symbols and as prefixes to symbols. The former are also used as subscripts to symbols. Numbers are used as subscripts only. The subscripts *o* and *p* are used with *T* to indicate respectively the position at the instant of firing (present position) and the predicted (future) position. These subscripts are used similarly with α , *D*, ϵ , *H*, *R*, and *t* to indicate the particular element corresponding to these two positions of the target. The other subscripts used have, in general, a special meaning, depending upon the symbol with which they are used.

Symbol	Pronounced	Definition
α	Alpha.....	Angle of approach.
α_o	Alpha sub o.....	Angle of approach of target at instant of firing (present position). Never greater than 90°.
α_p	Alpha sub p.....	Angle of approach of target at its predicted (future) position. Never greater than 90°.
γ	Gamma.....	Angle of dive, that is, angle between course of target and the horizontal.
γ_v	Gamma sub v.....	Projection of angle of dive on the vertical plane containing the gun and the target at its predicted (future) position.
<i>D</i>	<i>D</i>	Slant range.
<i>D_m</i>	<i>D</i> sub <i>m</i>	Slant range to target at midpoint of course.
<i>D_{min}</i>	<i>D</i> sub min.....	Minimum slant range. (For constant altitude courses, <i>D_{min}</i> equals <i>D_m</i> .)
<i>D_o</i>	<i>D</i> sub o.....	Slant range of target at instant of firing (present position).
<i>D_p</i>	<i>D</i> sub p.....	Slant range of target at its predicted (future) position.
δ	Delta.....	Lateral deflection angle.
δ_L	Delta sub L.....	Lateral lead. (This includes lead necessary for travel of target during time of flight.)
ϵ	Epsilon.....	Angular height.
ϵ_o	Epsilon sub o.....	Angular height of target at instant of firing (present position).
ϵ_p	Epsilon sub p.....	Angular height of target at its predicted (future) position.
<i>H</i>	<i>H</i>	Altitude of target.
<i>H_m</i>	<i>H</i> sub <i>m</i>	Altitude of target at midpoint of course.

COAST ARTILLERY FIELD MANUAL

Symbol	Pronounced	Definition
H_o	H sub o.....	Altitude of target at instant of firing (present position).
H_p	H sub p.....	Altitude of target at its predicted (future) position.
L	L.....	Distance in horizontal plane measured from midpoint of a crossing course to a point on the course. Positive if measured in direction of flight.
L_d	L sub d.....	Horizontal distance from the present position of a dive target to the objective.
L_m	L sub m.....	Horizontal distance from the midpoint to the objective of a dive target.
L_o	L sub o.....	Distance in horizontal plane from midpoint of course to present position of target (at instant of firing).
L_p	L sub p.....	Distance in horizontal plane from midpoint of course to predicted (future) position of target.
MV	MV.....	Muzzle velocity.
ϕ	Phi.....	Quadrant elevation.
ϕ_s	Phi sub s.....	Superelevation under firing table conditions.
R	R.....	Horizontal range.
R_d	R sub d.....	(On coming diving courses.) Horizontal distance from the present position of a dive target to the objective. On these courses, R_d equals L_d .
R_m	R sub m.....	Minimum horizontal range or range to target at midpoint of course (where α equals 90°).
R_o	R sub o.....	Horizontal range to target at instant of firing (present position).
R_p	R sub p.....	Horizontal range to target at its predicted (future) position.
S	S.....	Speed of target along its path.
S_o	S sub g.....	Ground speed of target. (For a diving course, S_o equals $S \cos \gamma$.)
$S_o t_p$	S sub g t sub p.....	Linear horizontal travel of target during time of flight.
σ	Sigma.....	Vertical deflection angle.
σ_1	Sigma sub one.....	Principal vertical lead angle.
σ_L	Sigma sub L.....	Vertical lead. (This includes lead necessary for travel of target during time of flight plus superelevation.)
T	T.....	Position of target.
T_m	T sub m.....	Position of target at midpoint of course (α equals 90°). On incoming courses, T_m is directly over the gun; that is, ϵ equals 90° .
T_o	T sub o.....	Position of target at instant of firing (present position).
T_p	T sub p.....	Predicted (future) position of target.
t	t.....	Time of flight.
t_o	t sub o.....	Time of flight to present position of target.
t_p	t sub p.....	Time of flight to future position of target.

APPENDIX II
LEAD CHARTS

Lead charts for certain courses and automatic weapons are included in this section. Any additional lead charts required will have to be constructed locally. (See chapter 4 for method of computation and construction.)

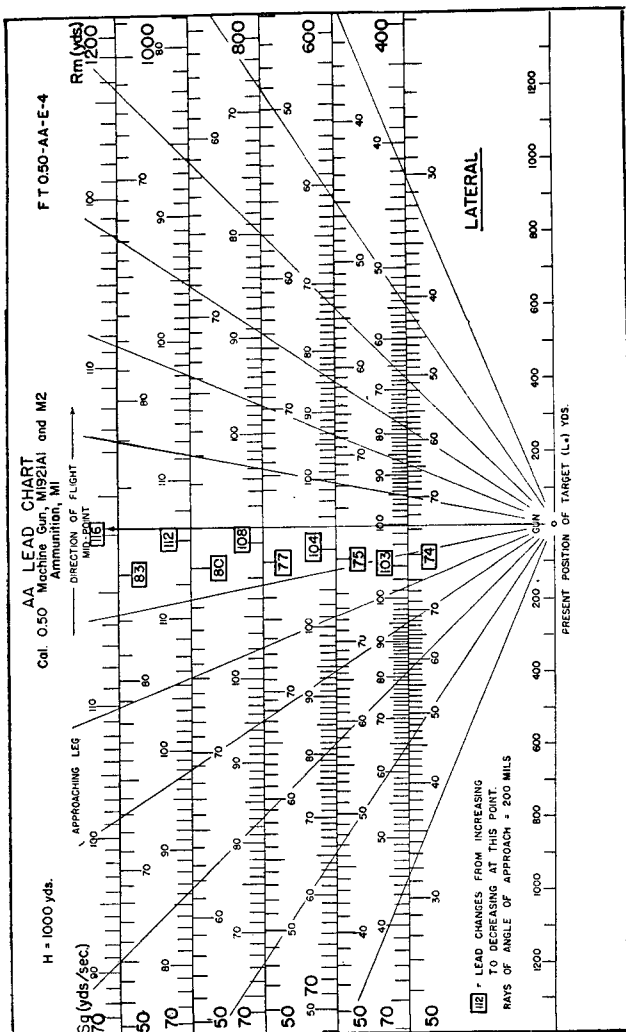

FIGURE 86.—Lateral lead chart, caliber .50 machine gun, crossing courses (see also fig. 22).

ANTI-AIRCRAFT AUTOMATIC WEAPONS

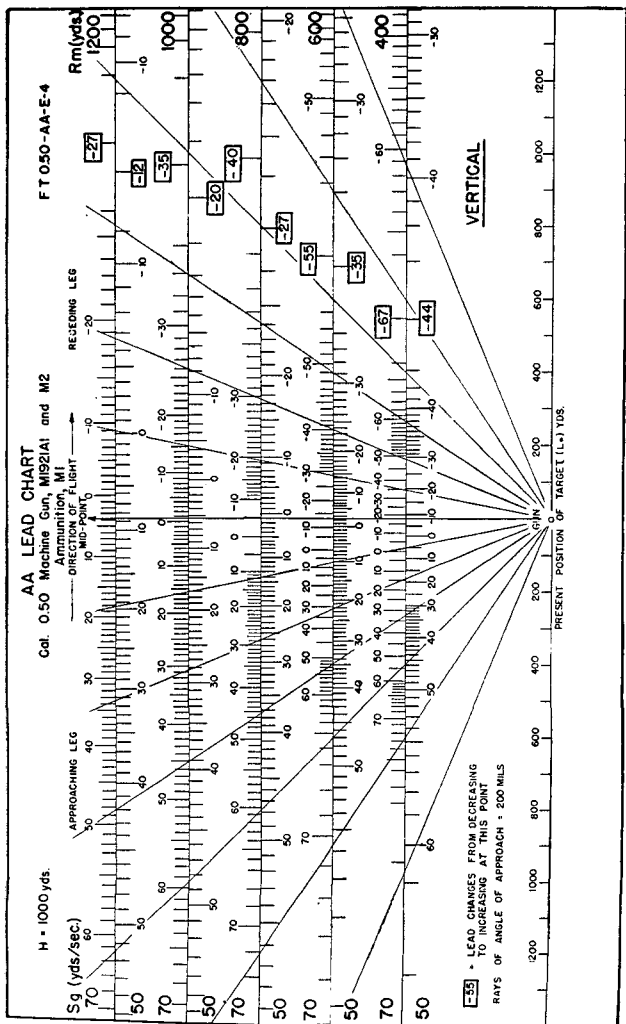

FIGURE 87.—Vertical lead chart, caliber .50 machine gun, crossing courses (see also fig. 23).

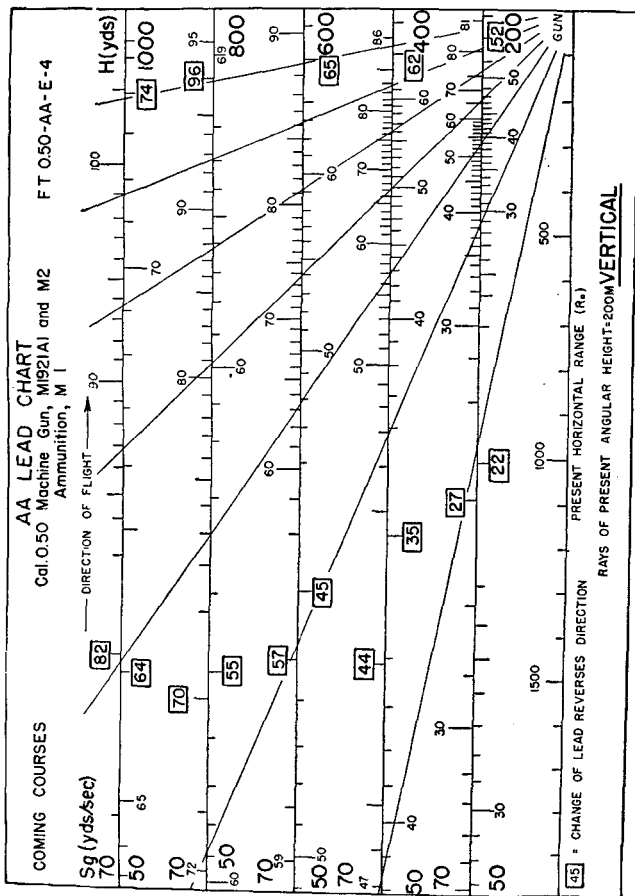

Figure 88.—Vertical lead chart, caliber .50 machine gun, coming courses.

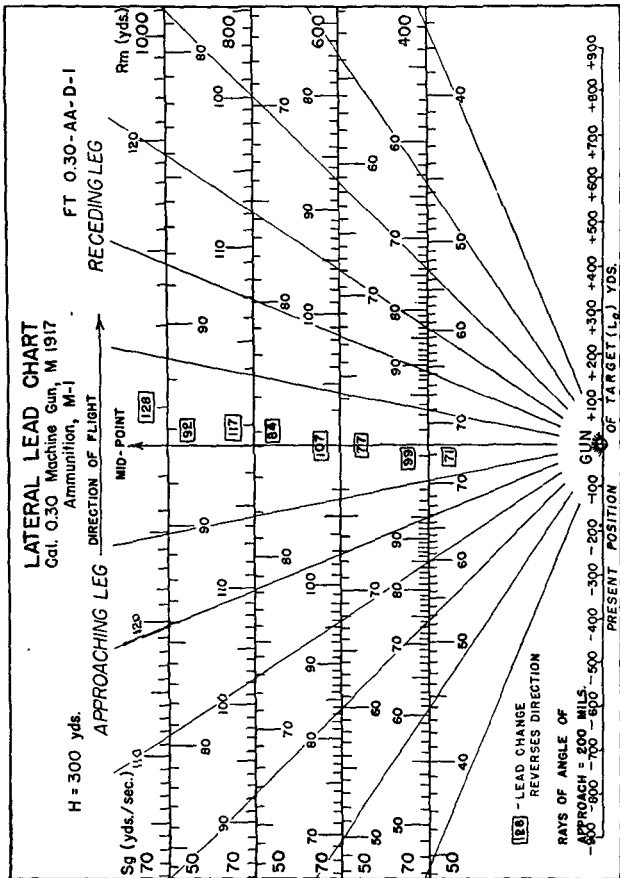

FIGURE 89.—Lateral lead chart, caliber .30 machine gun, crossing courses.

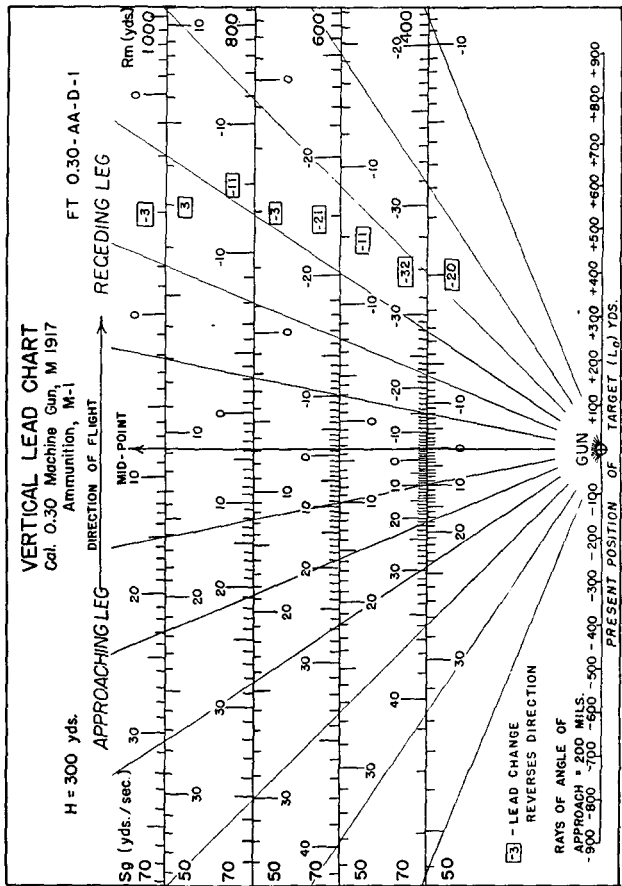
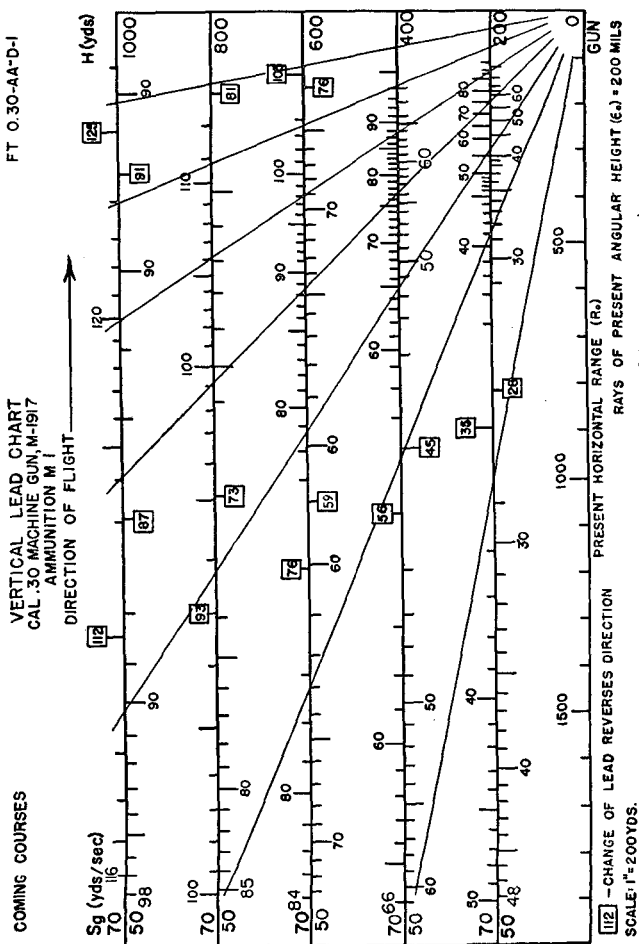

FIGURE 90.—Vertical lead chart, caliber .30 machine gun, crossing courses.

ANTI-AIRCRAFT AUTOMATIC WEAPONS



APPENDIX III

USE OF M1 (CRICHLow) SLIDE RULE

■ 1. DESCRIPTION.—*a.* The M1 (Crichlow) slide rule is a device used primarily in the solution of triangles. It consists of four concentric logarithmic scales and two movable transparent arms (one long arm (L) and one short arm (S)) pivoted at the center of the scales. Three of the scales are graduated proportional to various logarithmic functions of angles and the fourth proportional to the logarithms of numbers from 1 to 10. All of the scales have a common index line; therefore, all functions and numbers having common logarithms lie on the same radial line. In operation, the arms are moved through angles proportional to the functions or numbers being used.

b. The scales of the M1 slide rule are lettered successively inward as follows:

Scale D: $1/\sin$.

Scale E: Logarithmic scale of numbers.

Scale B: $1/\cos$.

Scale C: Tan or cot.

c. From the instructions on the face and back of the slide rule, it will be noted that the rule may be used to solve both right triangles and oblique triangles. These operations are not complicated. The following trigonometric formulas apply to the right triangle shown on the front of the slide rule:

$$\sin \epsilon = \frac{H}{D}, \quad H = D \sin \epsilon, \quad D = \frac{H}{\sin \epsilon}.$$

$$\cos \epsilon = \frac{R}{D}, \quad R = D \cos \epsilon, \quad D = \frac{R}{\cos \epsilon}.$$

$$\tan \epsilon = \frac{H}{R}, \quad H = R \tan \epsilon, \quad R = \frac{H}{\tan \epsilon}.$$

$$\cot \epsilon = \frac{R}{H}, \quad R = H \cot \epsilon, \quad H = \frac{R}{\cot \epsilon}.$$

■ 2. THEORY AND OPERATION.—*a.* The operation of any slide rule employs the basic principle of logarithms. This principle is: The sum of the logarithms of two numbers is equal to the logarithm of the product of the same two members. Applying this principle, it is evident that the logarithm of 3 plus the logarithm of 2 equals the logarithm of 6. If now a linear distance which represents the logarithm of 3 to a given scale is added to another linear distance which represents the logarithm of 2 to the same scale, the sum of these linear distances represents the logarithm of 6. The slide rule is a mechanical method of adding and subtracting linear distances. In the M1 slide rule the linear distances have been laid off around the circumference of four concentric scales. Since the relative positions of the scales are fixed, two arms are provided for making the additions and subtractions. By positioning these arms, the linear distance along the scale, which represents the desired logarithm, is thus transformed to the angle between the arms. To multiply two numbers, for example 2 and 3, proceed as follows:

(1) Set arm (S) on the index and arm (L) on the graduation on scale E marked "2." The angle then formed by the arms is proportional to the logarithm of 2.

(2) Without changing the angle between the arms, move arm (L) until arm (S) is on the graduation marked "3." The logarithm of 2 has been added to the logarithm of 3.

(3) Read the product under arm (L) as 6. Had we decided to divide 6 by 2, the angle corresponding to 2 would have been laid off in a counterclockwise direction from 6. In other words, the logarithm of 2 would have been subtracted from the logarithm of 6, and the arm (S) would have indicated the quotient as 3.

b. In like manner we may multiply the values of trigonometric functions represented on scales B, C, and D by each other or by any value on scale E. The following example

illustrates the multiplication of a function by a number on scale E:

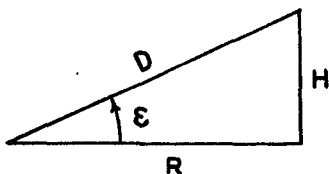

Given: $R=6,500$ yards; $\epsilon=750$ mils.

To find: D .

$$\text{Solution: } D = \frac{1}{\cos \epsilon} \times R.$$

(1) Place arm (S) on index, and set arm (L) on 750, scale B. The angle between the arms is then proportional to the logarithm of $\frac{1}{\cos 750}$.

(2) Without changing the angle between the arms, move arm (L) until arm (S) is over the 6,500 graduation on scale E. The logarithm of $\frac{1}{\cos 750}$ has been added to the logarithm of 6,500.

(3) Read the value of D under arm (L) on scale E as 8,780 yards. Scales C and D are used in a similar manner with other elements of right triangles. It is to be noted that scales D and B give the values for $\frac{1}{\sin}$ and $\frac{1}{\cos}$ respectively, whereas on scale C the values of the tangent or cotangent are given direct.

c. To use the M1 slide rule in calculating the leads for anti-aircraft automatic weapons, adaptations of the problems explained above are used. On the forms used for calculating leads will be found instructions for using the M1 slide rule to solve that particular equation.

■ 3. READING D SCALE.—*a. Sine function.*—When finding an angle by the use of the sine function (D scale), (1), (2), and (3) of the following table apply (see fig. on page 208):

If—	Read angle on—
When using sines	
(1) H greater than 0.1 of D	Middle set of figures on scale D.
(2) H less than 0.1 of D but greater than 0.01 of D .	Outer set of figures on scale D.
(3) H less than 0.01 of D	Outer set of figures on scale D with decimal point moved one place to the left.
When using tangents	
(Small angles—less than 105 mils)	
(4) H less than 0.1 of R	Outer set of figures on scale D.
(5) H greater than 0.1 of R but less than 0.103 of R .	Middle set of figures on scale D.
(Large angles—greater than 1,495 mils)	
(6) H greater than 10 times R	Outer set of figures on scale D and subtract from 1,600 mils.
(7) H less than 10 times R but greater than 9.7 times R .	Middle set of figures on scale D and subtract from 1,600 mils.

b. Tangent function.—Since the sine and the tangent of small angles (0–105 mils) are of approximately the same value, the M1 slide rule has been designed to read these small angles on the sine scale. When finding a small or large angle by the use of the tangent function (C scale), rules (4), (5), (6), and (7) of the above table apply.

(1) The following problems illustrate the procedure for small angles:

(a) $\tan \epsilon = \frac{H}{R}$, where $H=103$ yards and $R=1,040$ yards.

1. Set arm (L) on 1,040 on E scale.
2. Set arm (S) on 103 on E scale.
3. Move arm (L) so that arm (S) is on the index.
4. Using the *outer* set of figures on scale D, read ϵ as 101 mils under arm (L).

(b) $\tan \epsilon = \frac{H}{R}$, where $H=104$ yards and $R=1,030$ yards.

1. Set arm (L) on 1,030 on E scale.
2. Set arm (S) on 104 on E scale.
3. Move arm (L) so that (S) is on the index.
4. Using the *middle* set of figures on scale D, read ϵ as 103 mils under arm (L).

(2) The following problems illustrate the procedure for large angles:

(a) $\tan \epsilon = \frac{H}{R}$, where $H=1,040$ yards and $R=103$ yards.

1. Set arm (L) on 1,040 on E scale.
2. Set arm (S) on 103 on E scale.
3. Move arm (L) so that arm (S) is on the index.
4. Using the *outer* set of figures on scale D, read 101 mils under arm (L). ϵ equals 1,600 minus 101 or 1,499 mils.

(b) $\tan \epsilon = \frac{H}{R}$, where $H=1,030$ yards and $R=104$ yards.

1. Set arm (L) on 1,030 on E scale.
2. Set arm (S) on 104 on E scale.
3. Move arm (L) so that arm (S) is on the index.
4. Using the *middle* set of figures on scale D, read 103 under arm (L). ϵ equals 1,600 minus 103 or 1,497 mils.

c. Angles greater than 1,600 mils.—The inner set of figures on the D scale is used only when working with the sines of angles greater than 1,600 mils. The following problem is an illustration (see reverse side of slide rule):

(1) In right triangle O_1-T-O_2 :

Exterior angle at $O_1=2,050$ mils.

Angle at $T= 450$ mils.

Distance $O_1-O_2=3,000$ yards.

(2) To find side R_2 :

- (a) Set arm (L) to T (450) on scale D.
- (b) Set arm (S) at 2,050, inner figures, scale D.
- (c) Move arm (L) until arm (S) is on 3,000, scale E.
- (d) Read R_2 under arm (L), scale E, as 6,320 yards.

APPENDIX IV
 DRILL TABLE FOR CONTROL EQUIPMENT SET M1

DETAILS	PREPARE FOR ACTION	DETAILS, POSTS	TARGET	CEASE TRACKING	MARCH ORDER
Instrument corporal.	Repeats command and supervises work of entire detail. Indicates position of control box. Assisted by squad leader or gun commander of each gun, synchronizes control box with guns before flexible shafts are attached to guns. After shafts are attached, verifies synchronization. When range section is ready to function, reports to platoon commander, "Sir, range section in order."	Has no fixed post. Repeats command and moves around box so that he may supervise work of entire section.	Repeats command, giving any additional instructions necessary to aid adjusters and spotters in quickly picking up target.	Repeats command.	Repeats command and supervises work of placing all equipment in proper chests. Replaces equipment as directed.

DRILL TABLE FOR CONTROL EQUIPMENT SET M1—Continued

DETAILS	PREPARE FOR ACTION	DETAILS, POSTS	TARGET	CEASE TRACKING	MARCH ORDER
No. 1 (vertical adjuster).	Assisted by No. 2, removes control box from packing case and sets up control box at position indicated by instrument corporal. Connects flexible shafts to vertical output couplings of control box. Tests functioning of vertical adjusting knob. Sets vertical lead adjusting index to zero. When No. 3 has set vertical transmitted lead index at normal (500 for 37-mm gun and 300 for machine guns) and while vertical lead adjusting index is still at zero, checks to see that vertical lead index matches vertical transmitted lead index. If it does not, removes cover of vertical input coupling and rotates coupling until indexes are matched. Replaces coupling cover.	Takes post facing vertical adjusting knob.	Repeats command to vertical spotter, identifies target. Estimates initial vertical lead and sets it on vertical lead adjusting scale. Continues to change scale settings as required. Scale settings are changed to conform to his estimate of rate of change of leads. Observes tracers and receives vertical spotter's reports in order constantly to adjust his estimate of proper leads.	Repeats command to vertical spotter. Ceases operation of vertical adjusting knob but remains at post. Sets vertical lead adjusting index to zero.	Disconnects vertical flexible shafts from control box. Replaces covers on vertical output couplings. Assisted by No. 2, replaces control box in packing chest. Disconnects telephone and replaces it as directed.

ANTI-AIRCRAFT AUTOMATIC WEAPONS

<p>No. 2 (lateral adjuster).</p>	<p>Connects telephone to field wire to spotters.</p>	<p>Assists No 1 in removing control box from packing case and setting up control box at position indicated by instrument corporal. Connects flexible shafts to lateral output couplings of control box. Tests functioning of lateral adjusting knob. Sets lateral lead adjusting index to zero. When No. 4 has set lateral transmitted lead index at normal (500 for 37-mm gun and 300 for machine guns) and while the lateral lead adjusting index is still at zero, checks to see that lateral lead index matches lateral transmitted lead index. If it does not, removes cover of lateral input coupling and rotates coupling until indexes are matched. Replaces coupling cover. Connects telephone to field wire to spotters.</p>	<p>Takes post facing lateral adjusting knob.</p>	<p>Repeats command to lateral spotter. Identifies target. Estimates initial lateral lead and sets it on lateral lead adjusting scale. Continues to change scale settings as required. Scale settings are changed to conform to his estimate of rate of change of leads. Observes tracers and receives lateral spotter's reports in order constantly to adjust his estimate of proper leads.</p>	<p>Repeats command to lateral spotter. Ceases operation of lateral adjusting knob but remains at post. Sets lateral lead adjusting index to zero.</p>	<p>Disconnects lateral flexible shafts from control box. Replaces covers on lateral output couplings. Assists No. 1 in replacing control box in packing chest. Disconnects telephone and replaces it as directed.</p>
----------------------------------	--	--	--	---	---	---

COAST ARTILLERY FIELD MANUAL

DRILL TABLE FOR CONTROL EQUIPMENT SET M1—Continued

DETAILS	PREPARE FOR ACTION	DETAILS, POSTS	TARGET	CEASE TRACKING	MARCH ORDER
No. 3 (vertical matcher).	Removes flexible shafts from packing cases and stretches shafts for vertical leads from control box to individual guns. Connects two lengths of shafting together where necessary. Tests functioning of vertical lead handwheel. Sets vertical transmitted lead index at normal (500 for 37-mm and 300 for machine guns).	Takes post on seat facing vertical lead dial.	Matches indexes of vertical lead dial and carefully keeps them matched thereafter.	Ceases matching indexes of vertical lead dial, but remains at post. Sets vertical transmitted lead index at normal.	After vertical flexible shafts are disconnected from control box, replaces covers on shaft ends and then replaces shafts in packing chests.
No. 4 (lateral matcher).	Removes flexible shafts from packing cases and stretches for lateral leads from control box to individual guns. Connects two lengths of shafting together where necessary. Tests functioning of lateral lead handwheel. Sets lateral transmitted lead index at normal (500 for 37-mm and 300 for machine guns).	Takes post on seat facing lateral lead dial.	Matches indexes of lateral lead dial and carefully keeps them matched thereafter.	Ceases matching indexes of lateral lead dial, but remains at post. Sets lateral transmitted lead index at normal.	After lateral flexible shafts are disconnected from control box, replaces covers on shaft ends and then replaces shafts in packing chests.

ANTI-AIRCRAFT AUTOMATIC WEAPONS

<p>Nos. 5 to 10 inclusive (observers and spotters).*</p>	<p>Receive instructions as to where their stations will be located. Secure telephones and test them. Proceed to stations, laying field wire. Upon arrival at stations, each spotter connects his telephone to field wire and tests communication with adjusters.</p>	<p>Remain at their telephones in designated positions.</p>	<p>When fire is commenced, designated lateral and vertical spotters observe fire and telephone their observations (Right, Good, Left, or High, Good, Low, respectively), to the corresponding adjuster. Other spotters prepare to observe if called upon.</p>	<p>Cease telephoning observations if not already discontinued. Remain at posts.</p>	<p>Disconnect telephones. Return to control station, winding up field wire. Replace telephones as directed.</p>
<p>Nos. 11 and 12 (telephone operators).</p>	<p>Connect telephone to line laid to spotters (platoon commander's telephone) and connect telephone to line laid to platoon headquarters from battery headquarters. Test communication.</p>	<p>Take post at telephones.</p>	<p>Remain at post. Relay any messages given to them by platoon commander.</p>	<p>Remain at post. Relay any messages given to them by platoon commander.</p>	<p>Disconnect telephones and replace them as directed. Assist in taking up field wire at platoon position, as directed.</p>

*Numbers 9 and 10 are extras.

INDEX

	Paragraph	Page
Adjusters:		
Fire.....	100	157
Location.....	104	160
Physical requirements.....	101	157
Selection.....	104	160
Training.....	65, 109, 124-127	76, 163, 176
Adjustment fire.....	85, 91, 107-109, 127	132, 140, 161, 179
Aerial targets.....	2, 6, 7	1, 3, 4
Aircraft, capabilities.....	2, 7	1, 4
Altitude of target.....	53	32
Analysis of training (trainer).....	133	190
Angle of approach:		
Definition.....	53	32
Incorrect estimate, effects on lateral and vertical leads.....	76	109
Angle of dive, definition.....	53	32
Angular height of target, definition.....	53	32
Angular travel, lead computer.....	21	10
Antiaircraft automatic weapons problem. (See Automatic weapons problem.)		
Antimechanized defense:		
Adjustment of fire.....	85	132
Ammunition.....	83	130
Engagement ranges.....	84, 85	131, 132
Targets.....	84, 86	131, 137
Apparent tracer trajectory.....	99	155
Approximate director.....	34	14
Armored cars, characteristics.....	84	131
Automatic weapons:		
Aids in observing tracers.....	99, 116	155, 170
Basic assumptions.....	4	2
Capabilities.....	2, 3, 5	1, 2, 3
Problems:		
Ballistic factors.....	8	4
Elements of time.....	7	4
Gunnery factors.....	9	5
Possible solutions.....	11	6
Summary.....	10	5
Targets.....	6	3
Types.....	3	2
Ballistic effects on leads.....	78, 79	122, 127
Breech bore gaging.....	42, 79	18, 127
Ballistic factors, automatic weapons problem.....	8	4
Balloon firing.....	108, 109, 119	163, 173
Barrel wear, effect on muzzle velocity.....	42	18
Bilateral spotting.....	98, 104	154, 160
Breech bore gaging.....	42, 79	18, 127

	INDEX	Paragraph	Page
Calculation of leads:			
Computation forms	61, 62, 63, 64, 93		42, 47, 52, 61, 143
Constant altitude, coming courses	61		42
Constant altitude, crossing courses	63		52
Data	48-53, 60		28, 42
Diving, coming courses	62		47
Diving, crossing courses	64		61
General	48, 58		28, 41
Horizontal fire	92, 93		141, 143
Care and maintenance, data transmission system	116		170
Care and operation of control equipment set M1	44, 116		23, 170
Case III firing	116		170
Central tracer control	85, 90, 91, 102-106, 109		132, 140, 159, 163
Equipment	103, 109, 116, 126		159, 163, 170, 177
Characteristics of leads	73-80		102
Cold weather precautions	116		170
Coming-constant altitude course:			
Calculation of lead	61		42
Curves and charts	65-67		76
Differential effects	74, 78, 79		103, 122, 127
Elements of data	49		29
Lead characteristics	74, 80		103, 129
Coming-diving course:			
Calculation of lead	62		47
Curves and charts	68-72		83
Differential effects	75, 78, 79		105, 122, 127
Elements of data	50		30
Lead characteristics	75, 80		105, 129
Commands:			
Cease firing	107, 129		161, 181
Cease tracking	126		177
Change details	130		184
Commence firing	107, 129		161, 181
Practice run	130		184
Target	130		184
Target run	130		184
Track	126		177
Computed leads	29, 58-64		12, 41
Computers	20, 21, 29		10, 12
Conduct of fire	96-113		151
Cone of fire	39, 43, 96, 106		16, 22, 151, 161
Construction of lead chart	67		80
Dive targets	70		92
Horizontal	92-94		141
Control:			
Central tracer	102-106		159
Control equipment set M1	103, 129		159, 181
Director	33-38, 85, 91		13, 132, 140
Gun pointer	12-17		6
Off carriage sight	25-32		11
On carriage sight	18-24		9
Remote	27		12
Control box, central tracer	103, 126		159, 177
Conversion, lead chart leads into target lengths	95		147
Corrections for variations from standard con- ditions	57		38

INDEX

	Paragraph	Page
Corrective action, operating troubles, data transmission system.....	44, 131	23, 188
Crichlow slide rule.....	61-64, App. III	42, 206
Crossing-constant altitude course:		
Calculation of lead.....	63	52
Curves and charts.....	65-67	76
Differential effects.....	76, 78, 79	109, 122, 127
Elements of data.....	51	30
Lead characteristics.....	76, 80	109, 129
Crossing-diving course:		
Calculation of lead.....	64	61
Curves and charts.....	68-72	83
Differential effects.....	77-79	116
Elements of data.....	52	30
Lead characteristics.....	77, 80	116, 129
Cross wind, effect on lateral lead.....	57	38
Curves, lead.....	65-67	76
Data required for calculation of leads.....	48-53, 60	28, 42
Data transmission system:		
Electrical.....	113	166
General.....	110	165
Mechanical.....	112	166
Operating troubles.....	116	170
Telephonic.....	111	165
Definition of leads.....	59	41
Definitions of symbols.....	53, App. I	32, 197
Density, ballistic, differential effect.....	55, 57	36, 38
Depth perception.....	97	152
Derivation of formulas:		
Lateral lead.....	63, 64	52, 61
Vertical lead.....	61, 64	42, 61
Development of fire control:		
Central tracer control.....	26	11
Comparison of charts, varying gun objective distance.....	71	100
Computers.....	20, 21, 29	10, 12
Individual tracer control.....	14, 15	7
Oriented chart.....	28, 68-72	12, 83
Trajectory tunnel studies.....	129	181
Differential effects upon leads.....	74-78	103
Difficulties in observation of fire.....	99	155
Director:		
Approximate.....	34	14
Exact.....	35	14
M5 or M6.....	34, 91	14, 140
Director control.....	33-38	13
Dispersion:		
Due to gun pointing.....	40	16
Due to variation in time of flight.....	42	18
Free-mounted gun.....	45	25
Limiting.....	39, 40	16
Dive targets, lead charts for.....	68	83
Drill table for control equipment set M1.....	App. IV	211
Duties, platoon headquarters and range section.....	115, App. IV	168, 211

	INDEX	Paragraph	Page
Electrical data transmission.....		113	166
Element of time, automatic weapons problem....		7	4
Elements of data.....		48-53, 60	28, 42
Engagement ranges, horizontal fire.....		84, 85	131, 132
Erosion of barrels.....		42	18
Errors in pointing.....		40, 99	16, 155
Estimation of leads.....		7, 48, 100, 122	4, 28, 157; 175
Exact director.....		35	14
Expectancy, hit.....		45	25
Filters, use.....		99, 116	155, 170
Fire:			
Adjustment.....		48, 85, 91, 107-109	28, 132, 140, 161
Conduct.....		96-113	151
Control methods.....		85, 88, 90, 91, 100, 102	132, 138, 140, 157, 159
Individual.....		119	173
Night.....		15	7
Observation.....		96-99	151
Platoon.....		120	174
Firing tables.....		54, 55	35, 36
Flexible shafts, control equipment set M1....		103, 112, 116	159, 166, 170
Formation, platoon headquarters and range section.....		115	168
Forms, calculation of leads.....		61-64, 90	42, 140
Fortifications, assault on.....		87, 88	138
Forward area sights.....		13	6
Free-mounted gun, test dispersion.....		45	25
Gaging machine-gun barrels.....		42	18
Glossary of symbols.....		App. I	197
Ground speed of targets:			
Definition.....		53	32
Effect on leads.....		74, 75, 76, 77	103, 105, 109, 116
Gun-objective distance, effect on leads.....		71	100
Gun pointer control.....		12-17	6
Gun pointing.....		40, 121	16, 174
Gun, 37-mm, matching barrels.....		42	18
Gunner:			
Observation of fire.....		97, 100	152, 157
Selection.....		40, 101	16, 157
Training.....		40, 108	16, 163
Gunnery, automatic weapons.....		1	1
Gunnery factors, automatic weapons problem....		9	5
Hitting, probability.....		45	25
Horizontal distance along course, definition....		53	32
Horizontal fire.....		81-95	130
Antimechanized defense.....		83-86	130
Assault of fortifications.....		87, 88	138
Control.....		85, 88, 90, 91	132, 138, 140
Leads.....		85, 91, 92-94	132, 140, 141
Water-borne targets.....		89-91	139
Horizontal range, definition.....		53	32

INDEX

	Paragraph	Page
Immediate action.....	123	176
Individual firing.....	97, 100, 119	152, 157, 173
Individual tracer control.....	97, 100, 101	152, 157
Initial leads.....	101	157
Isolead curves.....	94	146
Landing boats, characteristics.....	89-91	139
Lateral lead charts:		
Caliber .50 machine gun, crossing.....	67, App. II	80, 199
Caliber .30 machine gun, crossing.....	App. II	199
Horizontal fire.....	93-95	143
Lateral leads, horizontal fire.....	92	141
Lead charts:		
Dive targets.....	68-72	83
General.....	65, 67, App. II	76, 80, 199
Horizontal fire.....	92-94	141
Lead computer.....	20, 21, 29	10, 12
Lead control, on carriage sight.....	19	9
Lead corrections for differential effects.....	79	127
Lead curves.....	65-67	76
Lead tables, horizontal fire.....	85, 95	132, 147
Leads:		
Ballistic effects.....	78	122
Calculation:		
Constant altitude, coming courses.....	61	42
Constant altitude, crossing courses.....	63	52
Dive targets, oriented lead charts.....	68-72	83
Diving, coming courses.....	62	47
Diving, crossing courses.....	64	61
Horizontal fire.....	92-94	141
Characteristics.....	73-80	102
Effect of ground speed:		
Elements of data.....	74-77	103
Estimation.....	7, 109	4, 163
General.....	58, 65	41, 76
Initial.....	65, 91, 100, 101	76, 140, 157
Lateral.....	53	32
Effect of cross wind on.....	57	38
Rate of change.....	48, 72, 107-109	28, 101, 161
Training in determining.....	65-72, 122	76, 175
Vertical, definition.....	53	32
Lengths and heights of targets in terms of mils.....	95	147
Linear speed lead computer.....	20	10
Location of spotters.....	98	154
Lubrication.....	116, 121	170, 174
Machine guns:		
Matching of barrels.....	42	18
Use of subcaliber.....	134	196
Maintenance.....	116	170
Maneuvering targets, adjustment of fire.....	7, 38	4, 15
Master lateral and vertical lead curves for record runs (trainer).....	133	190
Mechanical data transmission.....	112	166
Mechanical flexible shafts.....	103, 112	159, 166

INDEX

	Paragraph	Page
Mechanisms:		
Director M5 and 40-mm gun.....	34	14
Director M5 and 37-mm gun.....	34, 85, 91	14, 132, 140
Mechanized targets. (See Horizontal fire.)		
Methods:		
Lead calculation.....	58-64	41
Observation and adjustment of fire.....	96-99	151
Mils, conversion of target lengths to.....	95	147
Miniature training device.....	126	177
Minimum horizontal range.....	53	32
Mission, automatic weapons.....	2	1
Muzzle velocity:		
Armor-piercing ammunition.....	83	130
Differential effect, barrel wear.....	79	127
Differential effect, time of flight.....	42	18
Effect, variation in propelling charge.....	8	4
Night firing.....	15	7
Nonstandard conditions, corrections.....	57	38
Observation and adjustment of fire:		
Central tracer control.....	102-106	159
Fire adjustment.....	107-109	161
Individual tracer control.....	100	157
Methods of observation.....	96-99	151
Single station spotting.....	97, 100, 101	152, 157
Two station spotting (bilateral).....	98, 104	154, 160
Off carriage sight control.....	25-32	11
On carriage sight control.....	18-24	9
Operating troubles, data transmission systems.....	44, 116, 131	23 170, 188
Organization, platoon headquarters and range section.....	115	168
Oriented charts, dive targets.....	28, 68-72	12, 83
Personnel, selection.....	40, 101	16, 157
Phases of training.....	117	173
Platoon fire.....	120	174
Platoon headquarters and range section, automatic weapons.....	114-115	168
Pointing errors.....	40, 99	16, 155
Powder temperature, lead corrections for.....	79	127
Preparation, lead charts, dive targets.....	70	92
Principal lateral or vertical lead angle.....	53	32
Probability of hitting.....	46, 47	26
Problem:		
Automatic weapons.....	6-11	3
Horizontal fire.....	81-83	130
Problems, illustrative.....	56, 109, App. III	37, 163, 206
Purpose of training.....	118, 128	173, 180
Range section.....	115, 116	168, 170
Rate of change of leads.....	107-109	161
Rear wind, effect on leads.....	57	38
Red glasses, use.....	99, 116	155, 170
Relation of remaining velocity to time of flight.....	47	26
Remote control.....	27	12

INDEX

	Paragraph	Page
Safety precautions.....	121	174
Service conditions, lead characteristics.....	76, 78, 121	109, 122, 174
Shafts, flexible.....	44, 112	23, 166
Sighting system, 37-mm gun:		
Application of leads.....	85, 91	132, 140
Synchronizing.....	44	23
Sights:		
Forward area.....	13	6
Horizontal fire.....	85, 91	132, 140
Slant range.....	53	32
Spotters:		
Location.....	98	154
Number.....	98	154
Training.....	96-98, 124-127	151, 176
Use of filters or red glasses.....	99, 116	155, 170
Spotting:		
Bilateral.....	98, 104, 129	154, 160, 181
Unilateral.....	97, 100	152, 157
Spreading guns.....	43	22
Stoppages.....	123	176
Subcaliber firing.....	134	196
Superelevation:		
Definition.....	53	32
Effect of rear wind.....	57	38
Effect of variation in muzzle velocity.....	57	38
Firing tables.....	56	37
Horizontal fire.....	85, 93, 94	132, 143, 146
Symbols and definitions.....	53, App. I	32, 197
Synchronization.....	44, 131	23, 188
Tables, firing.....	54-57	35
Tanks:		
Characteristics.....	83, 84	130, 131
Engagement ranges.....	84, 85	131, 132
Principles of antitank fire.....	86	137
Target:		
Aerial, general characteristics.....	2, 6, 7	1, 3, 4
General.....	6	3
Position.....	53	32
Speed.....	7	4
Visibility at night.....	15	7
Target lengths.....	85, 95	132, 147
Telephonic data transmission.....	111	165
Time of flight:		
As function of hit expectancy.....	9	5
Definition.....	53	32
Effect of variation in density.....	57	38
Effect of variation upon dispersion.....	42	18
Firing tables.....	56	37
Variations.....	8, 42	4, 18
Tracer ammunition.....	96	151
Tracer control:		
Central.....	26, 102-106	11, 159
Difficulties in the observation of fire.....	99	155
Individual.....	14, 100	7, 157
Limitations.....	106	161

INDEX

	Paragraph	Page
Tracer control trainer:		
Analysis of training.....	133	190
Composition of training groups.....	130	184
Control equipment set M1.....	129	181
Description and use.....	129	181
Drill.....	130	184
General.....	128	180
Lead control unit.....	129	181
Master lateral and vertical lead curves.....	133	190
Preliminary instruction.....	130	184
Synchronization of equipment.....	131	188
Trajectory tunnel.....	129	181
Training device, miniature.....	126	177
Training of personnel:		
Fire adjustment.....	108-109	163
General.....	117-120	173
Individual fire.....	108	163
Leads.....	109, 122, 124-127	163, 175, 176
Phases.....	117	173
Preliminary.....	118	173
Training section, tracer control trainer.....	130	184
Trajectory, tracer.....	97-99, 100	152, 157
Trajectory tunnel.....	129	181
Transmission of data:		
Electrical.....	113	166
Mechanical shafts.....	112	166
Telephonic.....	111	165
Two-station spotting.....	98, 104	154, 160
Unarmored vehicles.....	84	131
Unilateral spotting.....	97, 100	152, 157
Vertical lead charts:		
Caliber .50 machine gun:		
Coming.....	App. II	199
Crossing.....	67, App. II	80, 199
Caliber .30 machine gun:		
Coming.....	App. II	199
Crossing.....	App. II	199
Construction.....	94	146
Vibration of mount or carriage.....	39, 41, 111	16, 17, 165
Water-borne targets:		
Adjustment of fire.....	91	140
Characteristics of targets.....	89	139
Fire control.....	90, 91	140
Selection of site.....	91	140
Wind, corrections for cross and rear.....	57	38

